

Models

Models	Temp	RH	CO2	VOC	Networkable*
SARB24T	•				•
SARB24TH	•	•			•
SARB24TG	•		•		•
SARB24TV	•			•	•
SARB24TGH	•	•	•		•
SARB24TGVH	•	•	•	•	•

* Networkable: BACnet MS/TP or Modbus (selectable via menu)

Features



- Inputs and outputs
 - One analog input (AI1)
 - One binary input (BI1)
 - Two analog outputs (2 AO), commandable via network
 - Two binary outputs (2 BO), commandable via network
- Enthalpy and dew point calculations (available via network)
- Display or hide all the required access for user interaction
- Backlit LCD with simple icon and text-driven menus
- Selectable Fahrenheit or Celsius scale
- BACnet[®] MS/TP or Modbus (selectable via menu)
 - Select MAC address via menu or via network
 - Automatic baud rate detection
 - Network service port via on-board mini USB connector



SARB Series

Technical Specifications

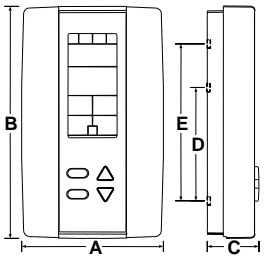
Description	SARB Series
Temperature Sensor	
<i>Sensor range</i>	-40°C to 125°C [-40°F to 257°F]
<i>Display resolution</i>	±0.1°C [0.2°F]
Humidity Sensor (SARB24TH, SARB24TGH and SARB24TGVH)	
<i>Sensor range</i>	5 to 95% RH
<i>Display resolution</i>	0.1% RH
CO₂ Sensor (SARB24TG, SARB24TGH and SARB24TGVH)	
<i>Operating principle</i>	Self-calibrating, Non-Dispersive Infrared (NDIR)
<i>Sensor range</i>	400 to 2000 ppm
<i>Accuracy</i>	±30 ppm ±3% of reading (Accuracy is defined after minimum 3 weeks of continuous operation)
<i>Response time</i>	2 minutes by 90%
VOC Sensor (SARB24TV and SARB24TGVH)	
<i>Operating principle</i>	Self-calibrating, Non-Dispersive Infrared (NDIR)
<i>Sensor range</i>	0-1000 ppb isobutylene equivalent tVOCs
<i>Response time</i>	< 5 seconds for tVOC
<i>Start up time</i>	15 minutes
Other	
Inputs	1 Analog input: 0-10Vdc or Thermistor (10k Type 3) 1 Binary input: digital input (dry contact)
Outputs	2 Binary outputs (BO1 and BO2), dry contracts 24Vac, 1A max 3A in-rush 2 Analog outputs (0 to 10Vdc)
BACnet	BACnet [®] MS/TP @ 9600, 19200, 38400, 57600 or 76800 bps (B-ASC)
Modbus	Modbus RTU slave @ 9600, 19200, 38400 or 57600. Selectable parity and stop bit configuration: No parity, 2 stop bit Even parity, 1 stop bit Odd parity, 1 stop bit
Communication Connections	24 AWG twisted-shield cable (Belden 9841 or equivalent)
Electrical connection	0.8 mm ² [18 AWG] minimum
Operating temperature	0°C to 50°C [32°F to 122°F]
Storage temperature	-30°C to 50°C [-22°F to 122°F]
Relative humidity	5 to 95 % non-condensing

Enclosure protection	IP 30 (EN 60529)
Weight	100 g. [0.22 lb]
Dimensions	 A = 2.85" 73mm B = 4.85" 123mm C = 1.00" 24mm D = 2.36" 60mm E = 3.27" 83mm
Certifications and Listings	

Wiring

We strongly recommend that all controllers be wired to a separate grounded transformer and that transformer shall service only these products. This precaution will prevent interference with, and possible damage to incompatible equipment.

Avoid touching the VOC and CO₂ sensors as this may cause incorrect readings



Terminal Description		Details
1	COM	
2	24Vac / 24Vdc	
3	COM for BO1 (ext 24V)	If JP1 is set to A+B
4	Binary Output 1 (BO1)	
5	COM for BO2 (ext 24V)	If JP2 is set to A+B
6	Binary Output 2 (BO2)	
7	COM	
8	Analog Input (AI1)	
9	COM	
10	Binary Input 1 (BI1)	
11	Analog Output 1 (AO1)	
12	COM	
13	Analog Output 2 (AO2)	
14	BACnet/Modbus A+	
15	BACnet/Modbus B-	

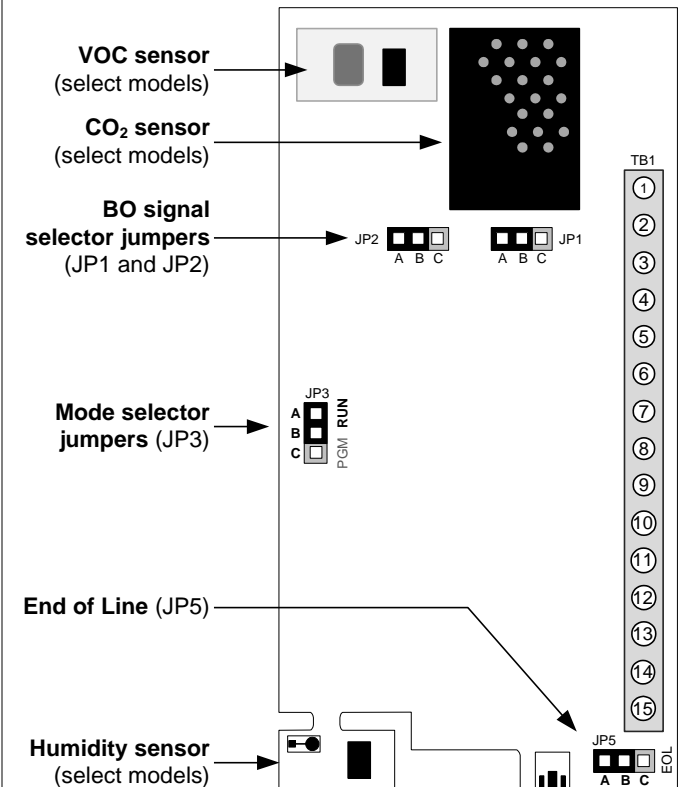

VOC sensor (select models)

CO₂ sensor (select models)

BO signal selector jumpers (JP1 and JP2)







Mode selector jumpers (JP3)

End of Line (JP5)

Humidity sensor (select models)

Terminal Block TB1: 1-15

Jumpers

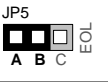
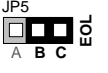
Jumpers		Description	
JP1	BO1 Signal Selection		A&B = External : BO1 uses external 24 Vac at pin 3 (different than thermostat)
			B&C = Internal : BO1 uses internal 24 Vac (same as thermostat)
JP2	BO2 Signal Selection		A&B = External : BO2 uses external 24 Vac at pin 5 (different than thermostat)
			B&C = Internal : BO2 uses internal 24 Vac (same as thermostat)
JP3	Mode Selection		A&B = RUN : Standard operation mode
			B&C = PGM : Programming/configuration mode
JP5	End of Line		A&B: No EOL (end of line).
			B&C: 120 Ohm end of line (on the last ARO of the RS-485 communication bus).

Mounting Instructions



CAUTION: Remove power to avoid a risk of malfunction.

- Remove the captive screw that's holding the base and the front cover of the unit together.
- Lift the front cover of the unit to separate it from the base.
- Pull all wires through the holes in the base.
- Secure the base to the wall using wall anchors and screws (supplied). Make the appropriate connections.
- Mount the control module on the base and secure using the screw.

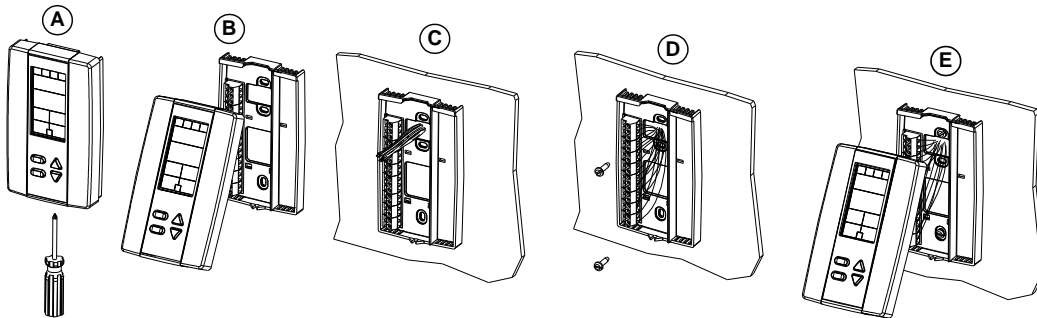

Programming Mode

i The Mode Selector Jumper JP3 must be set to the "PGM" mode (Programming Mode). Refer to Wiring on page 2. To exit, set the Jumper JP3 back to the "RUN" mode (Operation Mode). All changes will be saved.

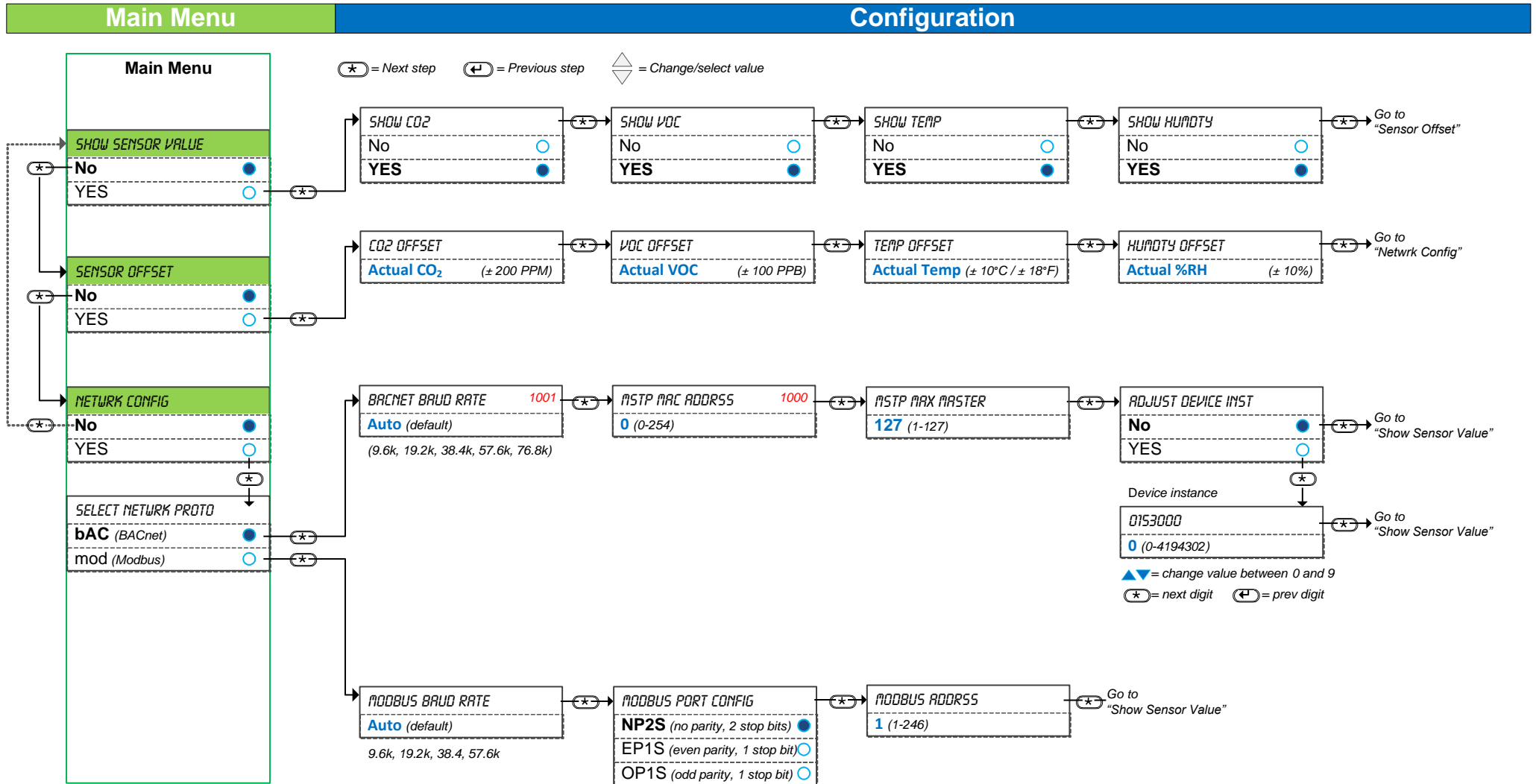



Operation Mode



The Mode Selector Jumper (JP3) must be set to the "RUN" mode (Operation Mode). Refer to Wiring on page 2.

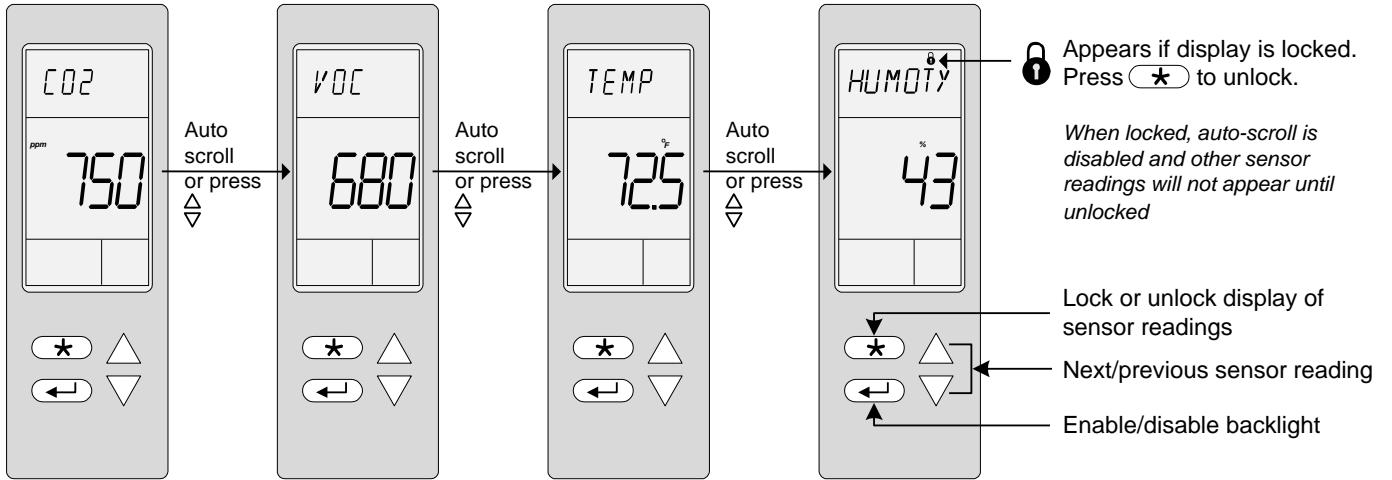

NOTE: The display of each sensor reading can be enabled or disabled via program (PGM) mode.



BACnet Device Object Properties

Property	Value	Writable
Object_Identifier	Programmable where the instance part of the Object_Identifier is in the range of 0-4194302. The device instance must be unique system-wide. The default value for the device instance=153000 (Vendor_Identifier*1000 + MSTP ADD)	W
Object_Name	Programmable up to 32 characters. The default value is Model_Name	W
Description	Programmable up to 32 characters. The default value is "Networkable Room Sensor"	W
Object_Type	Device	
System_Status	Always OPERATIONAL (0)	
Vendor_Identifier	Always 153	
Vendor_Name	Always Neptronic	
Model_Name	Example, SARGVH	
Firmware_Revision	currently, 1.07	
Application_Software_Version	currently, 1.27	
Protocol_Version	Always 1	
Protocol_Revision	Always 14	
DataBase_Revision	Default = 0, will be incremented if Object_Name and/or Object_Identifier is modified	
Max_APDU_Length_Accepted	Always 480	
Segmentation_Supported	(3) = No Segmentation	
APDU_Timeout	3,000	
Number_of_APDU_Retries	Always 3	
Protocol_Services_Supported	Always 0x00, 0x0B, 0xC0, 0x02, 0x60 (i.e. a bitstring in BACnet® order) <ul style="list-style-type: none"> • readProperty, readPropertyMultiple • writeProperty, writePropertyMultiple • deviceCommunicationControl • reinitializeDevice • who-Has, who-Is 	
Protocol_Object_Types_Supported	Always 0x00, 0xB4, 0x80, 0x10 (i.e. a bitstring in BACnet® order) <ul style="list-style-type: none"> • analog-input, analog-output • analog-value • binary-input, binary-output • binary-value • device • multi-state-value 	
Object_List	Per the standard. Because of restrictions on the size of the transmit buffers, the entire Object_List cannot be returned at once, rather the Object_List must be read, one-at-a-time.	
Device_Address_Binding	Always empty	
Max_Master	Programmable in the range of 1-127 (Default value=127)	W
Max_Info_Frames	Always 1	
Proprietary property #1000	<ul style="list-style-type: none"> • Programmable • This proprietary property represents the MS/TP MAC address in the range of 0-254 	W
Proprietary property #1001	<ul style="list-style-type: none"> • Programmable • This proprietary property represents the MS/TP baud rate • Values are 0 (auto), 9600, 19200, 38400, 57600, 76800 • Default is Auto 	W
Proprietary property #1002	<ul style="list-style-type: none"> • Programmable • This proprietary property represents the period of time that an object in/out of service will automatically return to normal. Range = 0-120 minutes (unsigned type) • Writing 0 means no automatic return to normal • Default is 15 minutes 	W



Object Table Information

The humidifiers use the following BACnet object tables, categorized on the basis of their ID. The type is the BACnet Object type, the instance is the BACnet Object. Together, the type and instance form the **BACnet Object_Identifier** for an object according to the following C-language algorithm:

$$\text{object_identifier} = (\text{unsigned long})((\text{unsigned long})\text{type} \ll 22) + \text{instance}$$

Analog Input (AI)

ID	Name	Description	Writable	Notes
AI.1	StatusAI1	Status value of analog input.	Out_of_Service	0 to 10Volts, Resolution 0.01Volt

Analog Value (AV)

ID	Name	Description	Writable	Notes
AV.9	StatusCO2Level	Represents the status of the carbon dioxide sensor (CO2). This is the value read by the CO2 sensor in parts per million (PPM).	Out_of_Service	0 PPM to 2,000 PPM, Resolution 1 PPM
AV.10	StatusTempLevel	Represents the internal temperature sensor reading.	Out_of_Service	-40°F to 257°F or -40°C to 125°C Resolution: 0.2°F/0.1°C
AV.11	StatusHumidityLevel	Represents the humidity sensor reading.	Out_of_Service	0%RH to 100%RH Resolution: 0.1 %RH
AV.13	StatusVOCLevel	Represents the VOC sensor reading.	Out_of_Service	0 PPB to 1,000 PPB Resolution: 1 PPB
AV.14	StatusOutdoorTempLevel	Represents the outdoor temperature at AI1 if MSV.18 is set to 2.	Out_of_Service	-40°F to 257°F or -40°C to 125°C or Resolution: 0.2°F/0.1°C
AV.15	StatusEnthalpy	Represents the calculated enthalpy.	Present Value	-133 BTU/lb to 148 BTU/lb or -327.00 kJ/kg to 327.00 kJ/kg, Resolution: 0.02 BTU/lb/0.01 kJ/kg
AV.16	StatusDewPoint	Represents the calculated dew point.	Present Value	-40°F to 257°F or -40°C to 125°C Resolution: 0.2°F/0.1°C
AV.27	CfgCO2Calibration	Configuration value applied to the displayed CO2 level reading that is used to calibrate against a known value from a CO2 sensing device.	Present Value	-200 to 200 PPM, Resolution 1 PPM
AV.28	CfgVOC Calibration	Configuration value applied to the displayed VOC level reading that is used to calibrate against a known value from a VOC sensing device.	Present Value	-100 to 100 PPB, Resolution 1 PPB
AV.29	CfgTempCalibration	Configuration value applied to the displayed temperature level reading that is used to calibrate against a known value from a thermometer or other temperature sensing device.	Present Value	-18°F to 18°F or -10°C to 10°C, Resolution 0.2°F/0.1°C
AV.30	CfgHumidityCalibration	Configuration value applied to the displayed humidity level reading that is used to calibrate against a known value from a humidistat or other humidity sensing device.	Present Value	-10% RH to 10% RH, Resolution 1% RH
AV.32	CfgOutdoorTempCalibration	Configuration value applied to the displayed outdoor air temperature level reading that is used to calibrate against a known value from a thermometer and/or other temperature sensing device Appears if temperature sensor offset at AI1 if MSV.18 is set to 2.	Present Value	-18°F to 18°F or -10°C to 10°C, Resolution 0.2°F/0.1°C



Binary Input (BI)

ID	Name	Description	Writable	Notes
BI.1	StatusBI1	Represents the status of the binary input 1 reading.	Out_of_Service	0 = Open, 1 = Close

Analog Output (AO)

ID	Name	Description	Writable	Notes
AO.1	StatusAO1	Status of analog output 1.	Present Value Relinquish Default	0% to 100%, Resolution 1%
AO.2	StatusAO2	Status of analog output 2.	Present Value Relinquish Default	0% to 100%, Resolution 1%

Binary Output (BO)

ID	Name	Description	Writable	Notes
BO.1	StatusBO1	Represents the contact status of the binary output 1.	Present Value Relinquish Default	0 = Open, 1 = Close
BO.2	StatusBO2	Represents the contact status of the binary output 2.	Present Value Relinquish Default	0 = Open, 1 = Close

Binary Value (BV)

ID	Name	Description	Writable	Notes
BV.9	CfgDisplayCO2Level	Display CO2 in RUN mode.	Present Value	0 = No, 1 = Yes
BV.10	CfgDisplay VOCLevel	Display VOC in RUN mode.	Present Value	0 = No, 1 = Yes
BV.11	CfgDisplayTempLevel	Display Temp in RUN mode.	Present Value	0 = No, 1 = Yes
BV.12	CfgDisplayHumidityLevel	Display %RH in RUN mode.	Present Value	0 = No, 1 = Yes
BV.16	CfgEnableBacklight	Represents the desired status of LCD backlight.	Present Value	0 = Off, 1 = On
BV.17	CfgEnableAuto-Scroll	Activate autoscroll of sensor readings in RUN mode.	Present Value	0 = Off, 1 = On
BV.18	CfgKeypadUpperLeftLock	Lock the star (*) button.	Present Value	0 = Off, 1 = On If set to "On", functionality of this button will not be available.
BV.19	CfgKeypadBottomLeftLock	Lock the enter/return button.	Present Value	0 = Off, 1 = On If set to "On", functionality of these buttons will not be available.
BV.20	CfgKeypadArrowsLock	Lock the arrow buttons.	Present Value	0 = Off, 1 = On If set to "On", functionality of these buttons will not be available.
BV.21	CfgProgramModeLock	Prevent access to Programming Mode.	Present Value	0 = Off, 1 = On If set to "On", access to Programming Mode will not be available.

Multi-State Value (MSV)

ID	Name	Description	Writable Property	Notes
MSV.7	CfgObjectListMode	Configuration value used to set the Object list mode. Integrator: Controller uses the Integrator object list mode. Advanced: Controller uses the Advanced object list mode. Factory: Controller uses the Factory object list mode.	Present Value	1= Integrator 2= Advanced 3= Factory
MSV.20	AI1Type	Value to select the input signal type for Analog Input 1 (AI1).	Present Value	1= Off 2= 10K Thermistor 3= 0_10Volt
MSV.21	Local Units	Unit type displayed on the thermostat.	Present Value	1= Metric 2= Imperial
MSV.22	Network Units	Unit type displayed via network.	Present Value	1= Metric 2= Imperial



Modbus Protocol

The SARB uses Modbus communication protocol over serial line in the RTU mode and provides a Modbus network interface between client devices and Neptronic devices. These instructions assume that you are familiar with Modbus terminology. The following are the requirements for Modbus:

- *Data Model.* The controller Modbus server data model uses only the Holding Registers table.
- *Function Codes.* The controller Modbus server supports a limited function codes subset comprising:
 - Read Holding Registers (0x03)
 - Write Single Register (0x06)
 - Write Multiple Registers (0x10)
- *Exception Responses.* The controller Modbus server supports the following exception codes:
 - Illegal function
 - Illegal data address
 - Illegal data value
 - Slave device busy
- *Serial Line.* The controller Modbus over serial line uses RTU transmission mode over a two-wire configuration RS485 (EIA/TIA-485 standard) physical layer.
 - The physical layer can use fixed baud rate selection or automatic baud rate detection (default) as per the **Modbus Auto Baud Rate** device menu item or holding register index 1.
 - The supported baud rates are 9600, 19200, 38400, and 57600.
 - The physical layer also supports variable parity control and stop bit configuration as per the **Modbus Comport Config** device menu item or holding register index 2.
 - In auto baud rate configuration, if the device detects only consecutive bad frames (2 or more) for one second with any given baud rate, it will reinitialize itself to the next baud rate.
- *Addressing.* The controller device only answers at the following address:
 - The device's unique address (1 to 246) that can be set through the device menu or through holding register index 0.



Table Glossary

Name	Description	Name	Description
W	Writable Register	ASCII	For registers containing ASCII (8-bit) characters
RO	Read Only Register	MSB	Most Significant Byte
Unsigned	For range of values from 0 to 65,535, unless otherwise specified	LSB	Least Significant Byte
Signed	For range of values from -32,768 to 32,767, unless otherwise specified	MSW	Most Significant Word
Bit String	For registers with multiple values using bit mask (example, flags)	LSW	Least Significant Word

Holding Register Table

Register Index	Description	Data Type	Range	W
40000	MSB = Neptronic ID LSB = Modbus address of current device	Unsigned	MSB = 18 LSB = 1-246	W
40001	MSTP Baud Rate	Unsigned Scale 100	0, 9600, 19200, 38400, or 57600, 0 = Auto Baud Rate Detection Value/100 (e.g. 38400 baud = 384)	W
40002	Communication port configuration	Unsigned	0 = No parity, 2 Stop bits 1 = Even parity, 1 stop bit 2 = Odd parity, 1 stop bit	W
40003	Product Name (characters 1 & 2)	ASCII	1 to 65535 MSB = char 1, LSB = char 2	W
40004	Product Name (characters 3 & 4)	ASCII	1 to 65535 MSB = char 3, LSB = char 4	W
40005	Product Name (characters 5 & 6).	ASCII	1 to 65535 MSB = char 5, LSB = char 6	W
40006	Product Name (characters 7 & 8).	ASCII	1 to 65535 MSB = char 7, LSB = char 8	W
40007	Actual firmware version	Unsigned	1 to 65535 (e.g. 101)	RO
40008	Actual ROM version	Unsigned	1 to 65535 (e.g. 123)	RO
40009	Alarms Status 1	Bit String	[B0 – B15]: Reserved	RO
40010	Alarms Status 2	Bit String	[B0 – B15]: Reserved	RO
40011	CO2 Level	Unsigned	0 to 2000 PPM	RO
40012	VOC Level	Unsigned	0 to 1000 PPB	RO
40013	Temperature Level	Signed Scale 10	Unit: °C/°F, Range: -40°C to 125°C or -40°F to 257°F Value x 10 (e.g. 23°C = 230 or 33°F = 330)	RO
40014	Humidity Level	Unsigned Scale 10	Unit: % RH, Range: 0%RH to 100%RH Value x 10 (e.g. 30%RH = 300)	RO
40015	Reserved			
40016	Enthalpy	Signed Scale 100	Unit: kJ/kg, -327 kJ/kg to 327 kJ/kg Unit: BTU/lb, -133 BTU/lb to 148 BTU/lb Value x 100 (e.g. 105.75 kJ/kg = 10575)	RO
40017	Dew Point	Signed Scale 10	Unit: °C/°F, Range: -40°C to 125°C or -40°F to 257°F Value x 10 (e.g. 23°C = 230 or 33°F = 330)	RO
40018	External Temperature Level	Signed Scale 10	Unit: °C/°F, Range: -40°C to 125°C or -40°F to 257°F Value x 10 (e.g. 23°C = 230 or 33°F = 330) Register 32 must be set to 10kOhms	RO
40019	AI1	Unsigned Scale 100	0 to 1000, Value x 100 (e.g. 2 mV = 200) Register 32 must be set to 0-10V	RO
40020	BI1	Unsigned	0 = Opened; 1 = Closed	RO
40021	CO2 Calibration	Signed	-200 to 200 PPM	W
40022	VOC Calibration	Signed	-100 to 100 PPB	W
40023	Temperature Calibration	Signed Scale 100	Unit: °C/°F, Range: -10°C to 10°C or -18°F to 18°F Value x 100 (e.g. 5°C = 500 or 10°F = 1000)	W



40024	Humidity Calibration	Signed Scale 100	Unit: %, Range: -10% to 10% Value x 100 (e.g. 5% = 500)	W
40025	Reserved			
40026	External Temperature Sensor Calibration	Signed Scale 100	Unit: °C/°F, Range: -10°C to 10°C or -18°F to 18°F Value x 100 (e.g. 5°C = 500 or 10°F = 1000) Register 32 must be set to 10kOhms	W
40027	AO1	Unsigned Scale 10	Unit: %, Range: 0% to 100% Value x 10 (e.g. 30% = 300)	W
40028	AO2	Unsigned Scale 10	Unit: %, Range: 0% to 100% Value x 10 (e.g. 30% = 300)	W
40029	BO1	Unsigned	0 = Closed, 1 = Opened	W
40030	BO2	Unsigned	0 = Closed, 1 = Opened	W
40031	Display Options	Bit String	B0: Display CO2 0 = No, 1 = Yes B1: Display VOC 0 = No, 1 = Yes B2: Display Temperature 0 = No, 1 = Yes B3: Display Humidity 0 = No, 1 = Yes [B4-B6]: Reserved B7: Enable Backlight 0 = Off, 1 = On B8: Enable Autoscroll 0 = Off, 1 = On [B9-B15]: Reserved	W
40032	AI1 Type	Unsigned	0= Off 1= 10kΩ 2= 0-10V	W
40033	Local Units	Unsigned	0= Metric 1= Imperial	W
40034	Network Units	Unsigned	0= Metric 1= Imperial	W
40035	Lock options	Bit String	[B0 – B3]: Reserved B4: Keypad Upperleft Lock 0 = Off, 1 = On B5: Keypad Bottomleft Lock 0 = Off, 1 = On B6: Keypad Arrows Lock 0 = Off, 1 = On B7: Program Mode Lock 0 = Off, 1 = On [B8 – B15]: Reserved	W

