



Models



Model #	Temp	RH	CO ₂	Color
TDU10-100 TDF10-100	•			grey LCD, white enclosure
TDU10-101 TDF10-101	•	•		
TDU10-102 TDF10-102	•	•	•	
TDU10-103 TDF10-103	•		•	



TDU10 Series



TDF10 Series

Model #	Temp	RH	CO ₂	Color
TDU40-100 TDF40-100	•			black LCD, black enclosure
TDU40-101 TDF40-101	•	•		
TDU40-102 TDF40-102	•	•	•	
TDU40-103 TDF40-103	•		•	



TDU40 Series



TDF40 Series

Model #	Temp	RH	CO ₂	Color
TDU70-100 TDF70-100	•			black LCD, white enclosure
TDU70-101 TDF70-101	•	•		
TDU70-102 TDF70-102	•	•	•	
TDU70-103 TDF70-103	•		•	



TDU70 Series



TDF70 Series

Features

Onboard Sensors

- Temperature sensor (°C/°F)
- Humidity sensor (%RH), select models
- Carbon dioxide sensor (CO₂), select models

Functions

- 90mm (3.5") LCD display
- Slim design
- Universal wall-mount design
- TDU series used to configure and operate the EVCB VAV controllers
- TDF series used to configure and operate the EFCB Fan Coil controllers
- Three wire connection between digital room sensor and controller
- Selectable Fahrenheit or Celsius scale
- Network service port via on-board mini USB connector
- Dimensions: 133mm x 95mm x 15mm (5.24" x 3.74" x 0.6")



Technical Specifications

Description	TDU10 / TDU40 / TDU70 / TDF10 / TDF40 / TDF70 Series
Temperature Sensor	
Setpoint Range	10°C to 40°C [50°F to 104°F]
Control Accuracy	Temperature: ±0.4°C [0.8°F]
Display Resolution	±0.1°C [0.2°F]
Humidity Sensor (select models)	
Setpoint Range (EFCB only)	10 to 65%RH
Control Accuracy (EFCB only)	±3.5% RH
Display Resolution	0.1%
CO₂ Sensor (select models)	
Operating Principle	Self-calibrating, Non-Dispersive Infrared (NDIR)
Sensor Range	400 to 2000 ppm
Accuracy	±30 ppm ±3% of reading (Accuracy is defined after minimum 3 weeks of continuous operation)
Response Time	2 minutes by 90%
Other	
Electrical connection	Three wires to EVCB/EFCB controller and two wires to BACnet/Modbus network 0.8 mm ² [18 AWG] minimum
Network service port	Mini USB connector
Power supply	24Vac
Power consumption	1VA
Operating temperature	0°C to 50°C [32°F to 122°F]
Storage temperature	-30°C to 50°C [-22°F to 122°F]
Relative Humidity	5 to 95 % non-condensing
Degree of protection of housing	IP 30 (EN 60529)
Weight	120 g. [0.25 lb]
Dimensions: A = 5.24" 133mm B = 2.87" 73mm C = 3.74" 95mm D = 1.22" 31mm E = 0.75" 19mm F = 2.00" 51mm G = 2.18" 55mm	

Interface

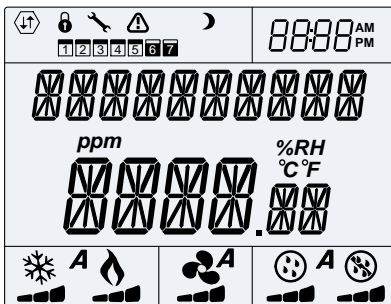

	Network Communication		User Lock		Programming Mode (Technician Setting)
	Alarm Status		Energy Saving Mode (NSB/OCC)		Schedule
	Time		ppm Parts Per Million		°C: Celsius Scale °F: Fahrenheit Scale %RH: Humidity
	A Automatic Mode		Cooling		Heating
	Fan		Humidify (EFCB only)		De-humidify (EFCB only)

Wiring

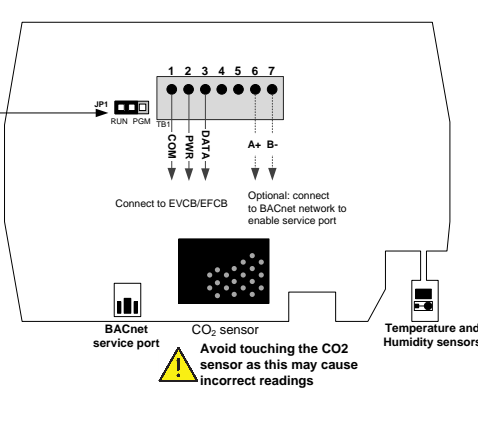

Mode Selector Jumper
 RUN = Operation Mode
 PGM = Programming Mode

Connect to EVCB/EFCB

Optional: connect to BACnet network to enable service port



BACnet service port

CO₂ sensor
 Avoid touching the CO₂ sensor as this may cause incorrect readings

Temperature and Humidity sensors

We strongly recommend that all Neptronic products be wired to a separate grounded transformer and that transformer shall service only Neptronic products. This precaution will prevent interference with, and/or possible damage to incompatible equipment.

Mode Selection (JP1)

 RUN	<p>RUN: Digital Room Sensor is in Operation Mode. Digital Room Sensor must be set in this mode to operate properly. If not locked, following setpoint and control mode options can be modified by the end user:</p> <ul style="list-style-type: none"> • Heating and Cooling ON • Cooling only ON • Heating only ON • OFF (EFCB only) • Fan ON • Humidify and De-humidify ON • Humidify only ON • Dehumidify only ON
 PGM	<p>PGM: Digital Room Sensor is set in Programming Mode.</p>

Mounting Instructions

 **CAUTION:** Remove power to avoid a risk of malfunction.



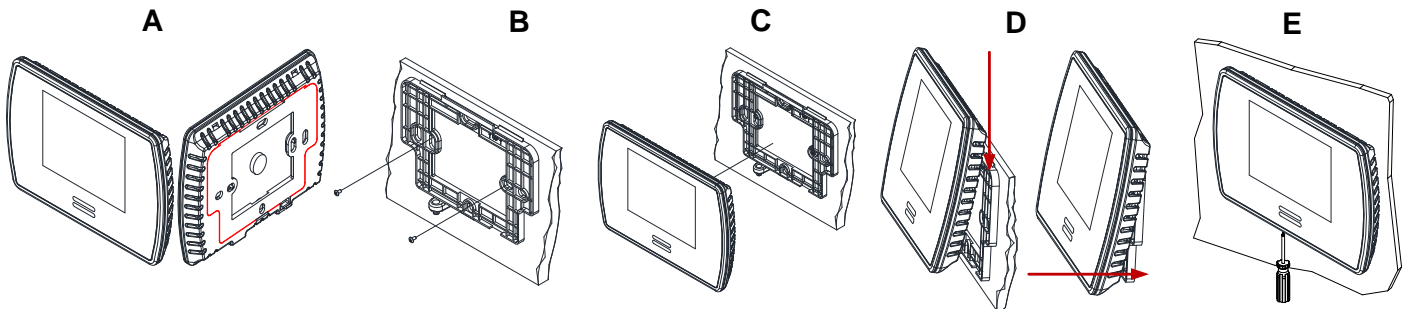

- A. Remove the wall mounting plate (highlighted) from the back of the Digital Room Sensor.
- B. Install the mounting plate on the gang box.
- C. Pull the wires through the base hole and make the appropriate connections.
- D. Mount the Digital Room Sensor onto the wall plate. To mount it correctly, place the top of the Digital Room Sensor on the mounting plate first and push it into the grooves to snap it into place.
- E. Secure the Digital Room Sensor using the screw (supplied).



Access to Menus

The menus and options are the same for both the TDU and TDF Digital Room Sensors. However, the action button or the button used to access the menus and save changes is different for each Digital Room Sensor.

Action Buttons on Digital Room Sensor

Action Button	
TDU	TDF
	
	

Operation Mode

The Mode Selector Jumper JP1 must be set to the RUN position (Operation Mode). Refer to the Wiring section on page 3.

EVCB

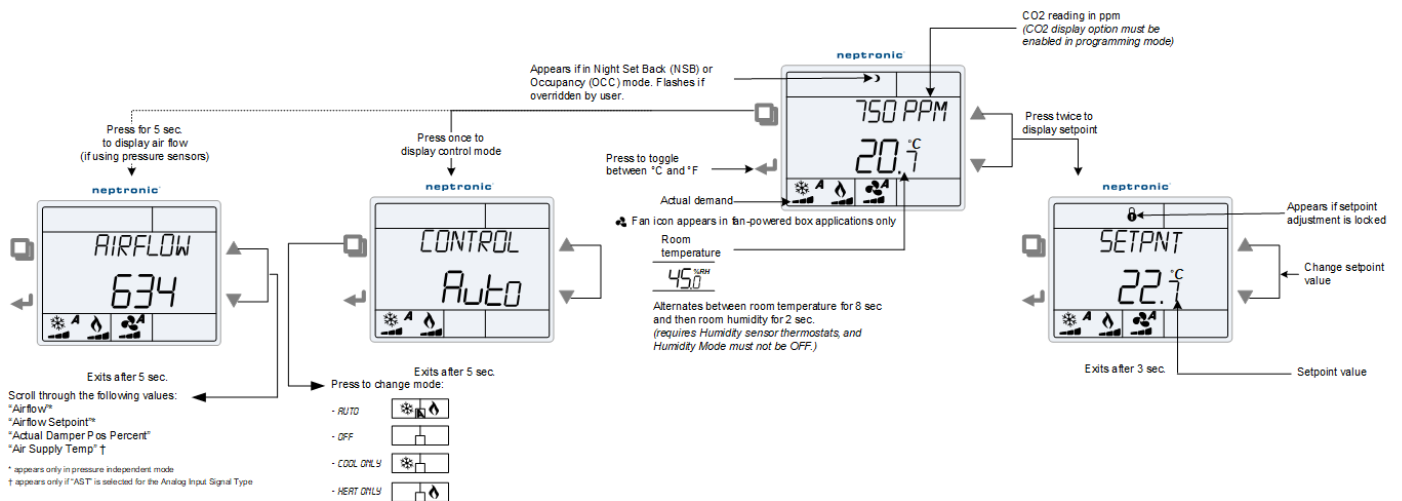

EFCB

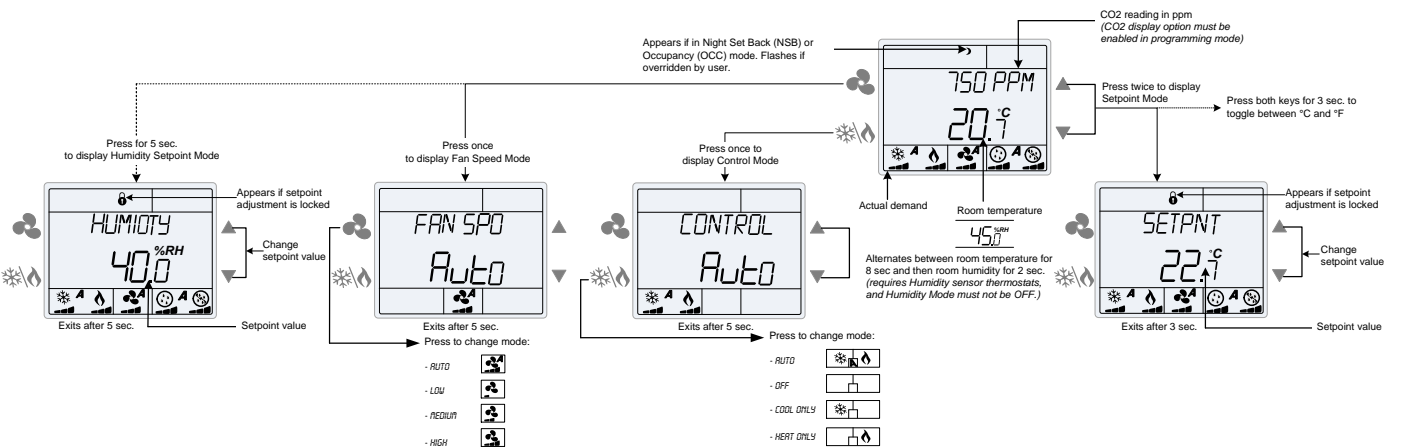



Power Up

Upon power up, the LCD illuminates and all segments appear for 2 seconds. The Digital Room Sensor then displays its current version for 2 seconds followed by the current version of the controller for 2 seconds. Pressing any key on the Digital Room Sensor illuminates the LCD for 4 seconds.

Temperature Display and Setpoint

The Digital Room Sensor displays the temperature reading. If the sensor is disconnected or short circuited, the unit displays the sensor's limits. To toggle the temperature scale between °C and °F, press the key on the TDU or both the and keys for 3 seconds on the TDF.

To display the setpoint, press the or key twice. The setpoint appears for 5 seconds. To adjust the setpoint, press the arrow keys while the temperature is displayed. If the setpoint adjustment has been locked, the lock symbol appears.

CO₂ (Digital Room Sensor with CO₂ Option)

If enabled via the configuration menu, the Digital Room Sensor displays the CO₂ reading on the first line above the temperature reading. If CO₂ display is enabled, the time will not be displayed.

Humidity Setpoint Display and Adjustment (Digital Room Sensor with Humidity Option)

If enabled via the configuration menu for the EVCB and in a humidity mode other than OFF for the EFCB, the Digital Room Sensor displays the temperature reading for 8 seconds and then displays the humidity reading for 2 seconds. If the sensor is disconnected or short circuited, then the unit displays the sensor's limit.

To access the humidity setpoint (EFCB only), press the key for 5 seconds. The humidity setpoint will be displayed for 5 seconds. To adjust the setpoint press the and keys while the setpoint is displayed. The unit will return to normal mode if you do not press any key for 3 seconds. The changed values will be saved automatically.

Control Mode

To access the Control Mode, press the key on the TDU or on the TDF. The Control Mode appears for 5 seconds. Press the (TDU) or (TDF) key to scroll through the following control modes. These options can vary depending on the options configured by the installer.

- Auto (Automatic Cooling or Heating)
- Cooling only (on, with cooling symbol)
- Heating only (on, with heating symbol)
- OFF (if it is not disabled in Programming Mode)

Fan Speed Selection Mode (EFCB Only)

To access the Fan Speed selection mode, press the key. The mode appears for 5 seconds. These options can vary depending on the fan speed signal and auto mode settings. If in No Occupancy mode, the button now serves as the override button.

- Automatic speed. Available only if enabled by the installer.
- Low speed
- Medium speed
- High speed

Night Set Back (NSB)

This function is only available if enabled by your installer. If the appropriate digital input contact is triggered, the Digital Room Sensor enters NSB Mode (the symbol appears) and uses the NSB setpoints defined in program mode. Press any key to override NSB for the delay defined in program mode (default: 120 minutes). The symbol flashes to indicate that the NSB mode is overridden (during this time the standard setpoints are used). If the NSB Mode was set to OFF, all outputs will be off for the duration of the period and cannot be overridden.

Occupancy Mode

This function is only available if enabled by your installer. If the appropriate digital input contact is triggered, the Digital Room Sensor enters Occupancy Mode (the symbol appears) and uses the NoOcc setpoints defined in program mode. If not locked, no occupancy mode can be overridden for a period by pressing the () button. Each time you press the () button, 15 minutes are added to the override (up to a maximum defined in program mode). Press the fan () button until "0" is displayed to disable the override. The icon will flash and the remaining override time will be displayed in minutes.



Set Time and Date

1. Press and hold the button for 5 seconds
2. Use the arrow keys to set the desired value. Press the () button to save and go to the next step. Press the button to go to the previous step without saving.

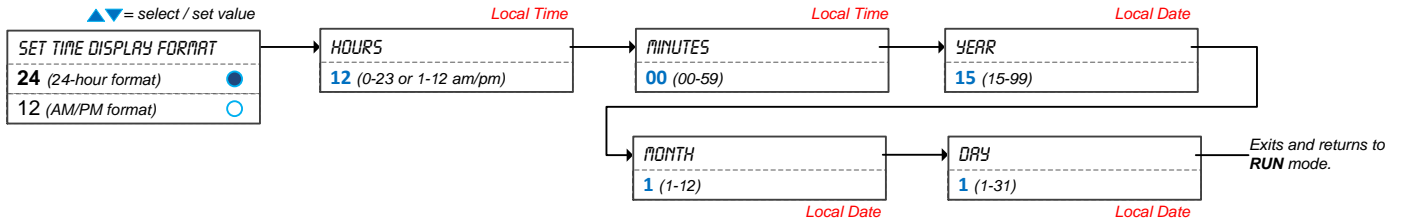

Airflow and Air Supply Temperature

Press and hold the () button for 5 seconds and use the arrow keys to view the "AIRFLOW", "AIRFLOW SETPNT", "ACTUAL DAMPER POS PERCENT" and "AIR SUPPLY TEMP". After 5 seconds without any action, the Digital Room Sensor returns to operation mode. The air supply temperature appears only if analog input AI1 or AI2 are configured with the AST option.

Programming Mode

To access the programming mode, the Mode Selector Jumper (JP1) must be set to the PGM (Programming Mode) position and terminal 3 (Data) must be disconnected from the Digital Room Sensor. Refer to the Wiring section on page 3 for more details.

Backlight and Contrast Level Adjustment

In programming mode, for models with the grey LCD screen, the backlight level can be adjusted. For models with the black LCD screen, the contrast level can be adjusted. Use the and keys to adjust the backlight or contrast level. Press the () key to save any changes.



Recycling at end of life: please return this product to your Neptronic local distributor for recycling. If you need to find the nearest Neptronic authorized distributor, please consult www.neptronic.com.



neptronic®

400 Lebeau blvd, Montreal, Qc, H4N 1R6, Canada

www.neptronic.com

Toll free in North America: 1-800-361-2308

Tel.: (514) 333-1433

Fax: (514) 333-3163

Customer service fax: (514) 333-1091

Monday to Friday: 8:00am to 5:00pm (Eastern time)