



**neptronic®**

# SKH4 High-Pressure Atomizer



**Installation Instructions and User Manual**

**Read and save this manual**



# Foreword

## Neptronic Company Overview

Founded in 1976, Neptronic is a private corporation that designs, manufactures and distributes products for the HVAC industry. Our product line includes intelligent controllers, electronic actuators, actuated valves, humidifiers and electric heaters.

Our products are designed and manufactured by over 250 dedicated employees in our 7,500 m<sup>2</sup> state-of-the-art facility located in Montreal, Canada. Our entire manufacturing chain is under one roof from software and hardware development to SMT circuit board assembly, to sheet metal fabrication, to product testing ensuring that our products are engineered to last using a vertical integration model.

We currently hold several national and international patents, and with our continued commitment to research and development, we provide innovative products and technologies for the ever-evolving challenges of the HVAC industry. Exporting over 75% of our sales, we have an exclusive distribution network around the globe that provides comprehensive solutions to our worldwide customers.

## About the Manual

These installation and operation instructions have been developed to facilitate the installation of the SKH4 High-Pressure Atomizer humidifier.

- The strict application of these instructions ensures conformity of your installation and operation as per the manufacturer's recommendations.
- The application of these instructions is one of the conditions for the application of the warranty.
- The application of these instructions does not ensure, at any time, conformity to procedures, regulation or local codes, regarding electric connections and installation to local water supply.

This product has been declared to conform to applicable European safety and electromagnetic compatibility standards and directives and bear the CE mark. The certificate of conformity CE is available upon request to the manufacturer.

## Copyright Information

Copyright ©2023 by Neptronic.

All rights reserved. This document cannot be reproduced wholly or partially by any means, whether electronic, mechanical, photocopy, recording or other, without prior written authorization of Neptronic.

# Health and Safety Instructions

## General

This manual has been written to ensure correct, safe and sustainable operation of the SKH4 High-Pressure Atomiser and is intended for use by engineers and technical personnel trained by or their official agents. This manual must be read thoroughly before specifying, designing, installing or operating a SKH4 High-Pressure Atomizer. Please retain for reference and contact Neptronic should you have any questions.



The triangular symbol with the word **WARNING**: is used to designate danger of severe or lethal consequence.



The circular symbol with the word **CAUTION**: is used to designate danger of injury, or to warn of the hazardous operating condition, or other relevant information.

## Electrical Warning Message



### **WARNING:**

Risk of electric shock. Do not access. Disconnect SKH4 High-Pressure Atomizer before opening the electrical access door.

All work concerned with electrical installation **MUST** only be performed by skilled and qualified technical personnel (such as an electrician or a technician with appropriate training). The customer is always responsible for ensuring the suitability of the technical personnel.

Please observe the local regulations concerning the provision of electrical installations.

## Health & Safety

Installation, maintenance, repair work or de-commissioning should only be carried out by appropriately qualified technical personnel. Any risks or hazards relating to the system, including during installation and maintenance, should be identified by a qualified Health & Safety representative who shall be responsible for introducing effective control measures, as necessary. The customer is responsible for ensuring that the installation of the equipment complies with all local regulations.



**CAUTION:** Maintenance personnel must be trained by Neptronic or their official agent, and it is the customer's responsibility to ensure their suitability. Failure to use qualified personnel may lead to a hazardous operating condition.



**WARNING:** Danger of Electrocution! Danger of contact with live parts when the unit is open. Always isolate all water and electrical supplies to the system before commencing any maintenance or repair. Isolate power and water immediately if there are any signs of water leaking from the unit.

## Protective Equipment

Please refer to the Health and Safety Executive for recommendations about Personal Protective Equipment and information on the Control of Substances Hazardous to Health (COSHH).

## Hygiene

### IMPORTANT:

Refer to local Health and Safety regulation and codes on the control of Legionellosis in water systems. In the absence of such, ASHREA guideline 12-2023 does provide recommendations. If not adequately monitored and maintained, water systems can support the growth of microorganisms including the bacterium that causes Legionnaires' disease.

The SKH4 has been designed to reduce the potential risk of legionellosis growth. Users also share the responsibility for reducing the risk of legionellosis; users are required to:

- Conduct a risk assessment of the complete water system.
- Implement proper control of the water system.
- Connect the SKH4 to a clean water supply main or higher quality water (such as RO).
- Avoid stagnant water.
- Avoid turning off the system without properly draining all conduit. Automatic drains are scheduled in the unit to avoid the stagnant water.
- Avoid water temperatures that increase the risk of Legionella growth. (25°C to 45°C)
- Clean and disinfect the system regularly, at least once a year.



**WARNING:** Risk of Legionnaires' disease, which can be fatal. Install and operate the SKH4 High-Pressure Atomizer as per the instructions given in this Installation Instructions and User Manual.



**WARNING:** If the SKH4 High-Pressure Atomizer is turned off for prolonged periods (more than 24 hours), ensure that any piping supplying the unit is drained, unless they supply other systems which ensure a regular renewal of water in the system. Failure to do so may result in stagnation of the water and contamination that might cause Legionnaires' disease, which can be fatal.

It is the responsibility of the person on whom the statutory responsibility falls to determine all control and preventative measures outlined in this manual.

## Correct Use

Neptronic systems and products are designed only for humidification and cooling use. Any other application is not considered appropriate for the intended purpose. The manufacturer cannot be made liable for any damage resulting from incorrect use.

## Important Start-Up Information

Before turning on and operating the SKH4 High-Pressure Atomizer:

- Read all instructions and installation procedures outlined in this manual. Ensure that the operation of the system is properly understood before commencing the start-up procedure.
- Ensure that all wiring is properly installed and that all connections have been made correctly, including the network communication cable between the pump station and the RVP(s).
- Verify all piping before starting up the system. As each zone may have a different capacity and the system has been configured as such, connecting the wrong RVP output to a zone may lead to erratic operation.

## General Warranty

This product is subject to the terms and conditions described at [www.neptronic.com/sales-conditions.aspx](http://www.neptronic.com/sales-conditions.aspx).

## Handling and Packaging

Lifting or Handling **MUST** be carried out by trained and qualified personnel. Ensure that the lifting operation has been properly planned, assessed for risk and that the equipment is checked by a qualified Health & Safety representative, and effective control measures are in place.



It is the customer's responsibility to ensure that the operators are trained in handling heavy goods and to enforce the relevant lifting regulations.

The SKH4 High-Pressure Atomizer **MUST** always be handled and lifted with care and should remain in its original packaging for as long as possible before installation.

The SKH4 High-Pressure Atomizer package may be carried using a forklift from the underside. Caution should be exercised to ensure balanced load before lifting.

### Correct Lifting Method

Any personnel handling or lifting the SKH4 High-Pressure Atomizer must follow the Lifting Operations and Lifting Equipment Regulations 1998 and Approved Code of Practice L113. The regulation imposes duties on employers and self-employed persons and authorities who have control, to any extent of lifting equipment.

### Inspection

Upon receipt, and once packaging material is removed, carry out an inspection to ensure that no damage occurred during transit. Report any damage immediately to your Neptronic representative.

### Unpacking

The SKH4 pump station is delivered in a crate. All other optional products, such as the distributors or the remote valve panel are delivered separately in carton.

# Table of Contents

Handling and Packaging .....	iv
Overview .....	6
SKH4 System .....	7
Principle of Operation .....	7
SKH4 Pump Station .....	8
Visual Overview .....	8
Pump Unit Nomenclature .....	10
Capacities and Power Consumption of Pump Unit (Brass) .....	11
Capacities and Power Consumption of Pump Unit (SS) .....	11
Dimensions and Weight .....	12
Fan-Assisted Distributors .....	13
Fan-Assisted Distributors Nomenclature .....	13
Capacities and Power of the Fan-Assisted Distributors .....	13
Fan-Assisted Distributors Dimensions and Weight .....	14
In-Duct Distribution Rack .....	15
Basic Installation Overview .....	16
Pump Unit Installation .....	17
Step 1 – SKH4 Pump Station Installation .....	17
General Recommendations .....	17
Step 2 – Water Connections for the SKH4 Pump Station .....	19
Step 3 – Power Supply Connections .....	22
Power Supply Connections on SKH4 Pump Station .....	22
Power Supply Knockout Holes Location on SKH4 Pump Station .....	23
Step 4 – Electrical Control Connections .....	24
Safety Contact Connections for Pump Unit .....	24
Safety Contact Connections Single Zone Without TRUB .....	24
Safety Contact Connections per Zone from TRUB .....	25
Network Communication .....	26
Step 5 – Pump Controller Installation and Configuration .....	27
Idle Screen .....	28
Configuration parameters .....	29
Control function .....	29
Control Profile Selection .....	29
Single Zone Operation .....	29
Multi-Zones Operation .....	30
Menu - General .....	31
Menu - User Settings .....	34
Menu - Service .....	36
Menu - Installation .....	37
Menu - Integration .....	41
List of Alarms and Warnings .....	44
Distribution Installation .....	45
Spraying in Space (Standard) .....	45
Spraying in Space with Fan-Assisted Distributors .....	47
Spraying in Duct .....	49
Optional – Remote Valve Panel (RVP) .....	50
Location .....	51
Positioning .....	51
Wall Mounting .....	51
Start-Up Procedure .....	53
Servicing and Maintenance .....	57
Preventative Maintenance .....	57
Nozzle Cleaning .....	59
De-scaling the Droplet Separator .....	60

## Overview

---

The SKH4 High-Pressure Atomizer uses water through a high-pressure system to produce a fine mist with a droplet size of less than 20µm. The ambient air absorbs the fine mist, and the SKH4 adapts to seasonal changes to provide direct evaporative cooling in summer and humidification in winter. Additionally, the SKH4 provides BACnet MS/TP communication, multi-zone operation (up to 4 zones) and remote connection to the entire system from any zone.

## Benefits

- Very low energy consumption
- Free cooling (up to 12°C)
- Hygienic operation
- Environmentally friendly
- Low pressure drop in ventilation conduit

## Features

The following are the features of the SKH4 High-Pressure Atomizer:

- High pressure pump with recirculation valve integrated.
- Full stainless steel distribution valves and fittings.
- Corrosion resistant distribution network made of stainless steel pipe or nylon tube.
- BACnet communication (optional).
- User-friendly, menu-driven LCD (128 x 64).
- Real-time clock and SD card or USB key for schedule, trending, and history log.
- Firmware upgrade using an SD card or USB key.

# SKH4 System

---

## Principle of Operation

The SKH4 High-Pressure Atomizer is a system for humidifying and cooling with a fine mist of water droplets. The pump unit pressurizes the high-quality water until it reaches a pressure of 69bar, then distributes it throughout a network of stainless steel pipes or nylon flexible conduits, which then distributes the pressurized water as a fine mist. These water particles measure less than 20µm. This mist is then easily absorbed into the air, providing humidification, and cooling, through the adiabatic evaporation process.

The SKH4 Pump Unit is equipped with a pump and a motor that can use an optional VFD in order to control the pump speed. The regulation of the outlet pressure is assured mechanically by the pump, in order to maintain a consistent and reliable outlet pressure, regardless of the configuration of stages open.

The unit is equipped with two analog manometers place in the front, one for the low pressure and one for the high-pressure outlet. There are also digital manometers so that the controller can monitor those pressures. The low pressure controls the input of water to the pump in order to protect the pump unit from running dry. The high-pressure sensor monitors the output of the pump, in order to assure consistent mist generation and detect leakage.

In case of unexpected shutdown and failure of valve that could create a water hammer coming back to the pump, a pressure relief is placed in the recirculation loop. The relief valve prevents damage to the inlet of the pump and the low-pressure components.

The distribution of high-pressure water is assured in the pump unit, or optionally from a remote valve panel, with an array of configurable valves. Each pair of valves (one for the input and one for the drain) is assigned at the installation to a capacity in mass per hour and to a control signal. The unit is able to receive up to 4 control signals in order to cover 4 different zones, which can also be split up into 6 stages in total.

The control signals are displayed either by using a thermostat in each zone that is connected to the unit or by connecting through a BMS with a demand directly to the unit. The BMS can be connected via BACnet or Modbus protocols.

The distribution of mist is accomplished by using anti-drip stainless steel nozzles which are designed to create a cone of mist to shoot the water droplets directly into the air. The nozzles are either installed directly in the space or in an AHU.

In-space distribution requires installing distribution piping (stainless steel or nylon flexible conduit), with a fitting for each nozzle. Clearances are important between nozzles and any obstacle in the area, such as trusses, columns and/or tall equipment. See the hydraulic and distribution design guide for more details.

In-space distribution can be facilitated with optional fan-assisted distributors. Those distributors allow reduced absorption distances and improve the coverage of the distribution network.



# SKH4 Pump Station

## Visual Overview

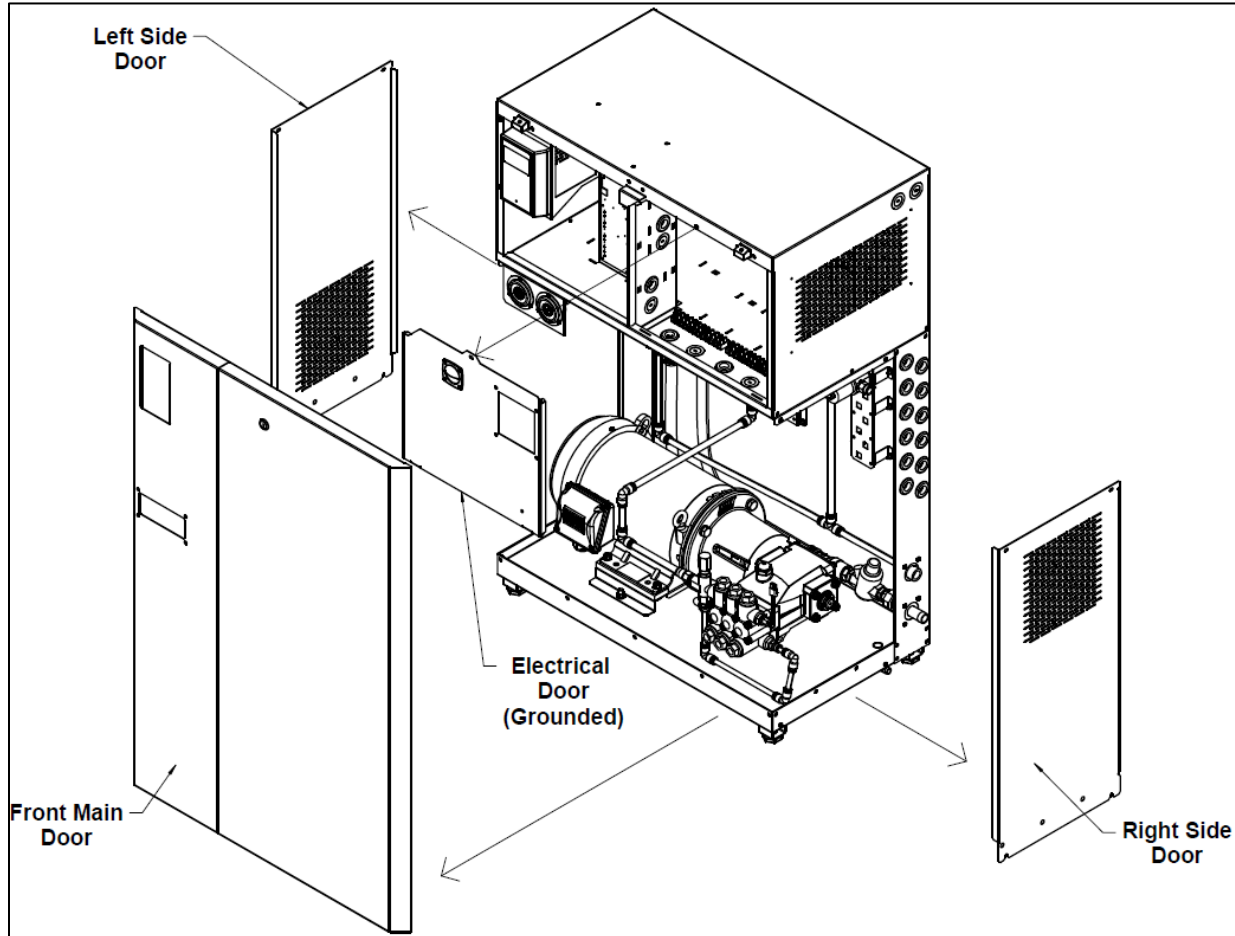

Illustration 1 - SKH4 Enclosure

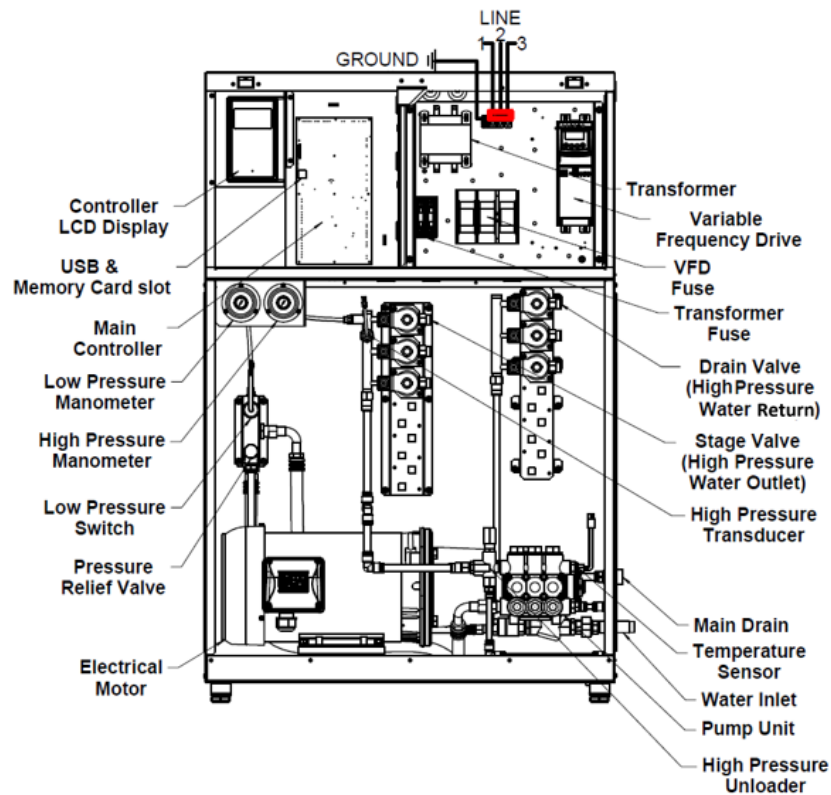

Illustration 2 - Detailed Overview of Components

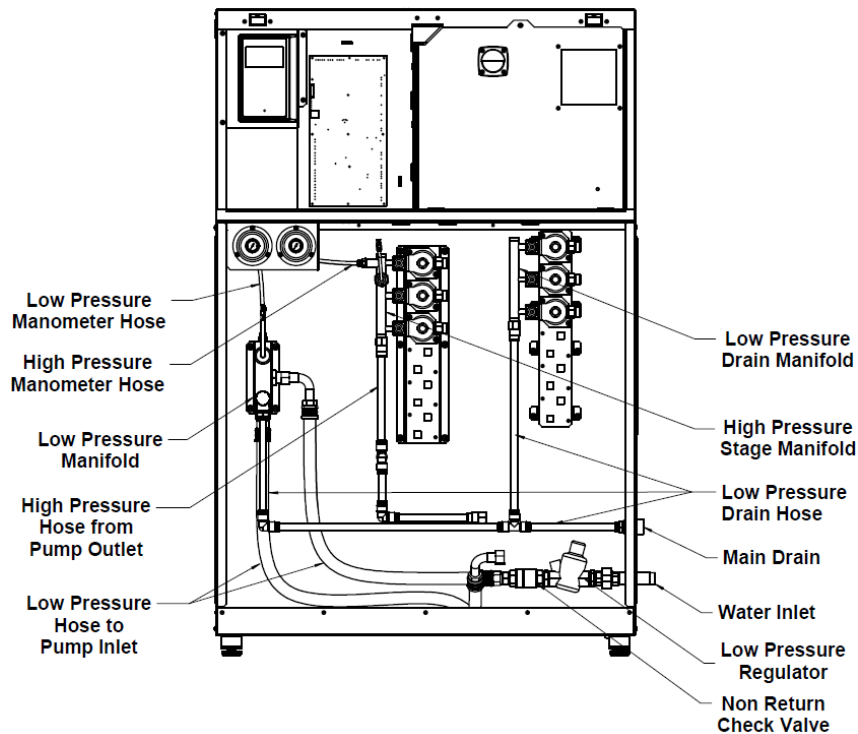

Illustration 3 - Detailed Overview of Low Pressure Components

## Pump Unit Nomenclature

Table 1 - Pump Module Nomenclature

Pump Module Nomenclature		
SKH4-ABBBC DD EF		
Designation	Notation	Description
<b>A</b>	E: Europe - 50Hz	Frequency
<b>BBB</b>	008 to 1250	Capacity (L/h)
<b>C</b>	B (Brass)	Pump Type
	S (Stainless)	
<b>DD</b>	0 to 6	Number of Inlet Valves (Zero implies valve in the RVP)
	0 to 6	Number of Drain Valves (Zero implies valve in the RVP)
<b>E</b>	C: 220-240 VAC / 1ph	Supply Voltage
	F: 400 VAC / 3ph	
<b>F</b>	[blank] (On/Off)	Motor Control
	M (Modulating - Controlled with VFD)	

## Capacities and Power Consumption of Pump Unit (Brass)

Table 2 - Capacities and Power Consumption of the Pump Unit (Brass)

Brass Pump						
Model	Power (kW)	Max Output (L/h)	Min Output (L/h)	RLA (A)		Cabinet
				C	F	
				240/1	400/3	
SKH4-E008B	0.3	80	20	-	2.8	S
SKH4-E010B - M	0.3	100	10	7.5	4.5	S
SKH4-E018B	0.7	180	45	-	3.7	S
SKH4-E022B - M	0.7	220	10	12.1	6.8	S
SKH4-E037B	1.5	375	94	-	5.6	S
SKH4-E045B - M	1.5	450	10	18.1	11.4	S
SKH4-E070B	3.7	705	176	-	10.8	L
SKH4-E085B - M	3.7	850	10	-	23.8	L
SKH4-E104B	3.7	1040	260	-	10.8	L
SKH4-E125B - M	3.7	1250	10	-	23.8	L

## Capacities and Power Consumption of Pump Unit (SS)

Table 3 - Capacities and Power Consumption of the Pump Unit (SS)

Stainless Steel Pump						
Model	Power (kW)	Max Output (L/h)	Min Output (L/h)	RLA (A)		Cabinet
				C	F	
				240/1	400/3	
SKH4-E028S - M	1.1	280	28	16.3	9.1	S
SKH4-E060S - M	2.2	600	60	-	15.5	S
SKH4-E100S - M	3.7	1000	100	-	23.8	L
SKH4-E125S - M	3.7	1250	125	-	23.8	L

## Dimensions and Weight

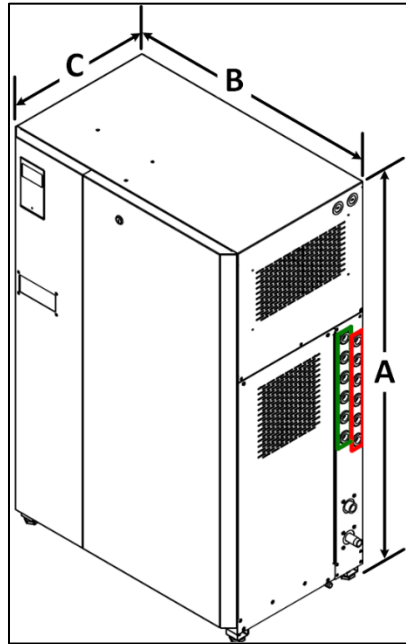

Illustration 4 - SKH4 Pump Unit Dimensions

Table 4 - Pump Station Dimensions

Enclosure Type	Model	Dimensions (mm)			Weight (kg)
		A	B	C	
Small Enclosure	SKH4-E008B	1130	724	345	136
	SKH4-E010B				
	SKH4-E018B				
	SKH4-E022B				
	SKH4-E037B				
	SKH4-E045B				
	SKH4-E028S				
SKH4-E060S					
Large Enclosure	SKH4-E070B	1184	778	475	145
	SKH4-E085B				
	SKH4-E104B				
	SKH4-E125B				
	SKH4-E100S				
	SKH4-E125S				

# Fan-Assisted Distributors

## Fan-Assisted Distributors Nomenclature

Table 5 - Fan-Assisted Distributors Nomenclature

Fan-Assisted Distributors Nomenclature		
SKH4-AAA BBBB C DD		
Designation	Notation	Description
AAA	MDU	Radial distribution unit
	ADU	Axial distribution unit
BBBB	0100 to 2500	CFM
C	C: 240 VAC / 1ph	Supply Voltage
DD	01 to 20	Number of spray nozzles

## Capacities and Power of the Fan-Assisted Distributors

Table 6 - Fan-Assisted Distributors Capacity and Power

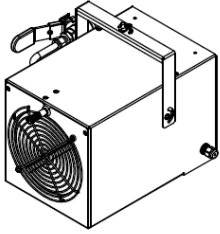
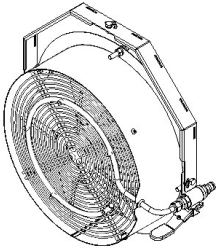
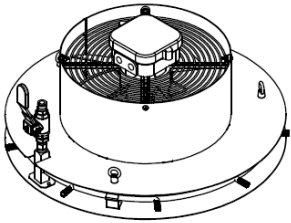
Model	Nozzle Capacity	m <sup>3</sup> /h (CFM)	Voltage	RLA (A)	Mounting	Illustration
<b>ADU (Axial)</b>	1 (3kg/h to 4.5kg/h)	340 (200)	240V (50Hz)	0.5	Wall mounted	
	5 (15kg/h to 22.7kg/h)	1700 (1000)	240V (50Hz)	0.5	Wall mounted	
<b>MDU (Radial)</b>	9 (27.2kg/h to 54.4kg/h)	1700 (1000)	240V (50Hz)	0.5	Suspended	

## Fan-Assisted Distributors Dimensions and Weight

Table 7 - Fan-Assisted Distributors Dimensions and Weight

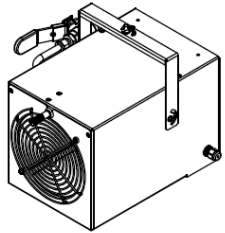
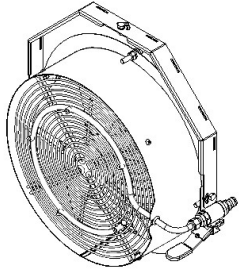
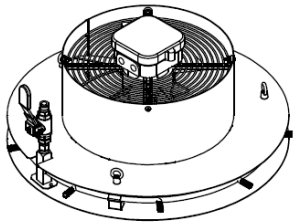
Model	Nozzle Capacity	Dimensions (mm)	Weight (kg)	Mounting	Illustration
<b>ADU (Axial)</b>	1 (3l/h to 5l/h)	308 x 239 x 267	3.6	Wall mounted	
	5 (15l/h to 25l/h)	Diameter 465 x 213	7.7	Wall mounted	
<b>MDU (Radial)</b>	9 (27l/h to 45l/h)	Diameter 516 x 229	10	Suspended	

For more information on the absorption distance, please refer to the Distributors Guide.

## In-Duct Distribution Rack

---

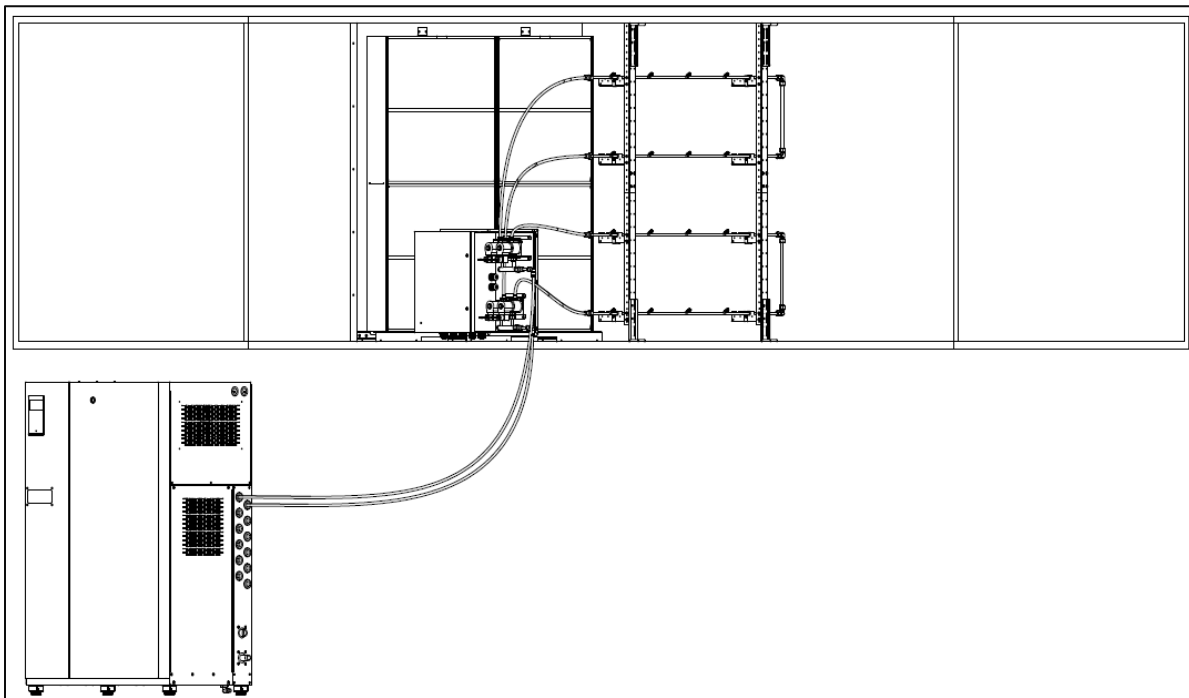

Illustration 5 - In-Duct Distribution

Dimensions and weight vary for each installation, consult with the factory in order to get a quote and detailed drawings for each application.

Refer to the Duct Distribution Guide for more details on how to install the duct rack and droplet separator.



## Basic Installation Overview



**WARNING:** Failure to observe manufacturer's installation recommendations voids the manufacturer's warranty.

### Installation Summary

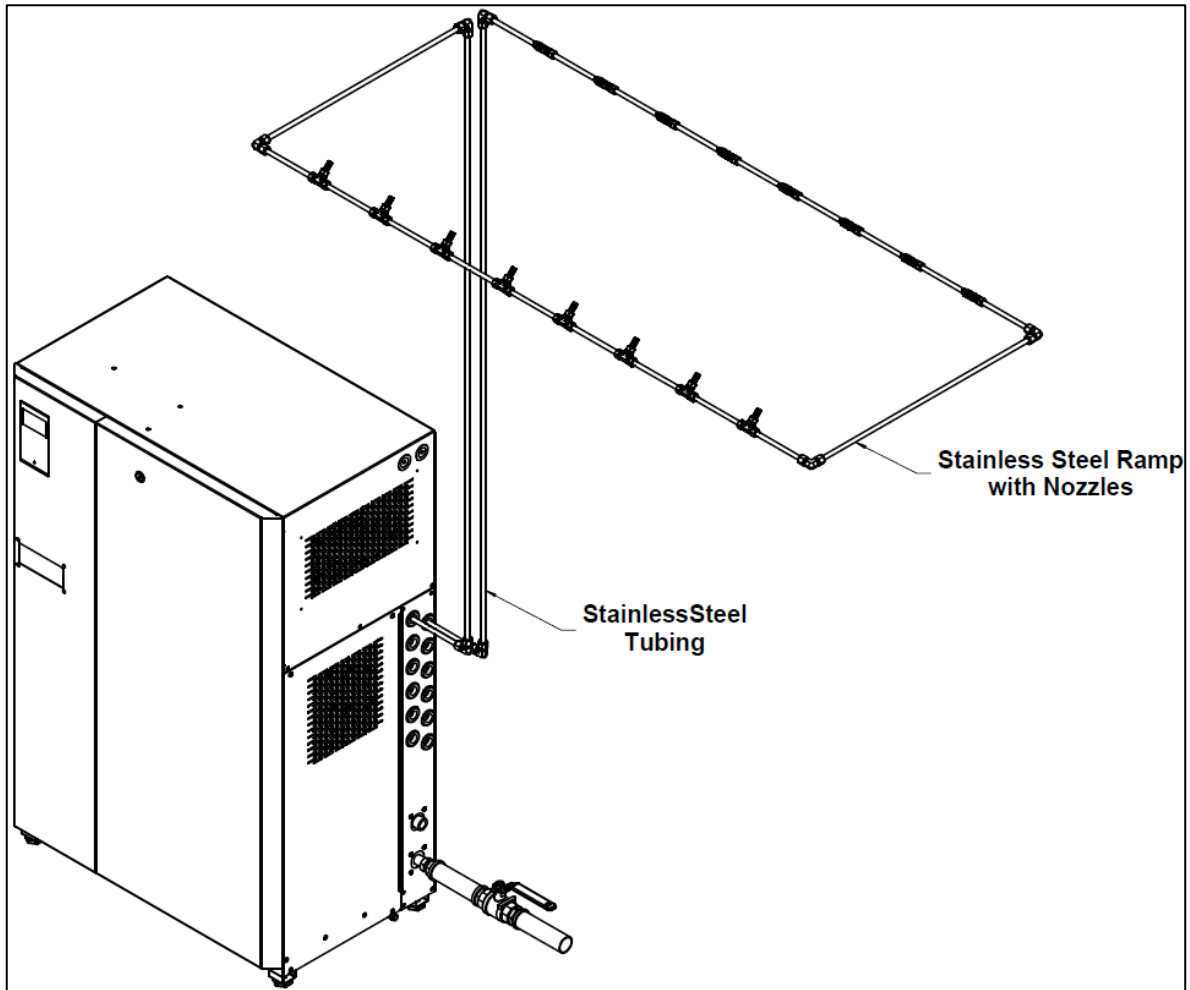

Illustration 6 - Overview of a Typical System Distribution in Space

# Pump Unit Installation

- Step 1 – SKH4 Pump Station Installation
- Step 2 – Water and Drain Connections
- Step 3 – Power Supply Connections
- Step 4 – Control Connections
- Step 5 – Pump Controller Installation and Configuration

## Step 1 – SKH4 Pump Station Installation

### General Recommendations



**WARNING:** Risk of electric shock. Disconnect the appliance from the electric supply before commencing installation.



**CAUTION:** Risk of injury. The SKH4 pump station is heavy; It **MUST** always be handled and lifted with care.

### Location

Consider the following points before deciding the location for the pump station:

- Plan a location that is easy to access to permit an easy inspection and servicing of the pump station.
- Do not install the pump station where the failure of the appliance could cause damage to the building structure or other equipment.
- Ensure that the location is ventilated appropriately, and that the ambient temperature is less than 30°C.
- Ensure that the floor beneath the SKH4 pump station is waterproof to withstand any water spillage during servicing or if a problem occurs.

### Positioning

- The pump unit can be floor mounted, either directly or with the use of a floor stand, or it can be wall mounted.
- Allow some space beneath the pump station for the drain pan connection, located below the bottom plate.
- Respect the clearances around the pump station as shown in this illustration, in order to permit access to the connections and allow for servicing:

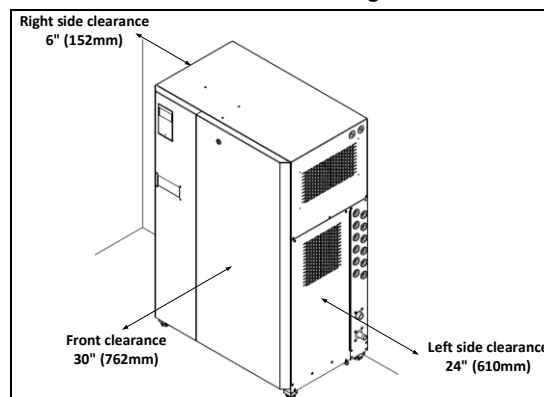

Illustration 7 - Clearances

### Floor Mounting

- Provide a level, solid foundation for the SKH4 pump station.
- Ensure that the SKH4 pump station is leveled with the provided with adjustable legs.
- Allow some space beneath the pump station for the drain pan connection, located below the bottom plate.

### Wall Mounting

- Provide a level, solid foundation for the SKH4 pump station.
- Allow some space beneath the pump station for the drain pan connection, located below the bottom plate.

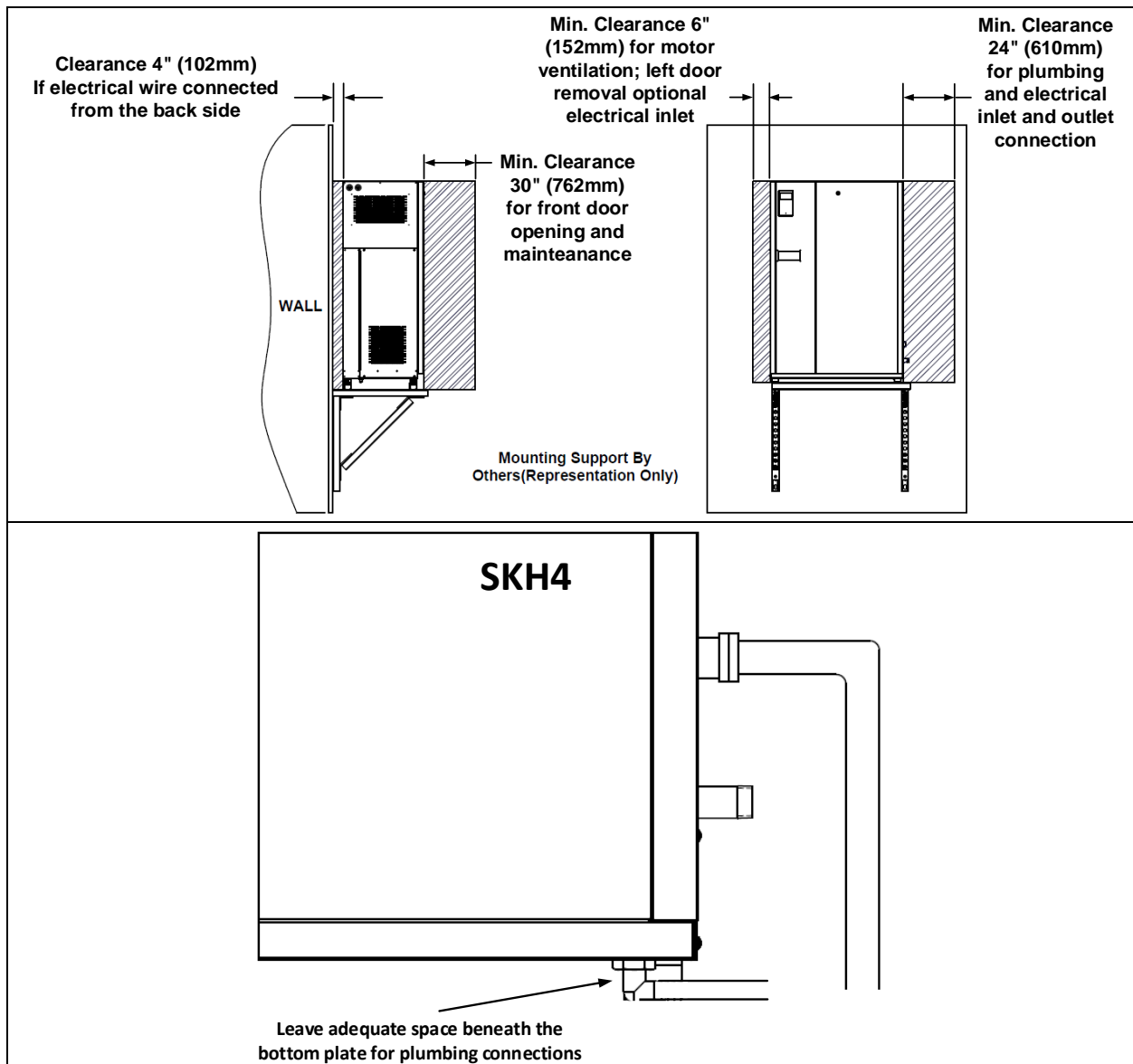

Illustration 8 - Wall Mounting & Clearances

## Step 2 – Water Connections for the SKH4 Pump Station

- Install an isolation valve (not supplied) on the water line near the pump station inlet for ease of maintenance and servicing. Place the valve in front of the water filter if used.
- Install a 1-micron filter (not supplied) on the water line near the pump station inlet for ease of maintenance and servicing.
- Flush the water line thoroughly before connecting the feed water pipework to the pump station.

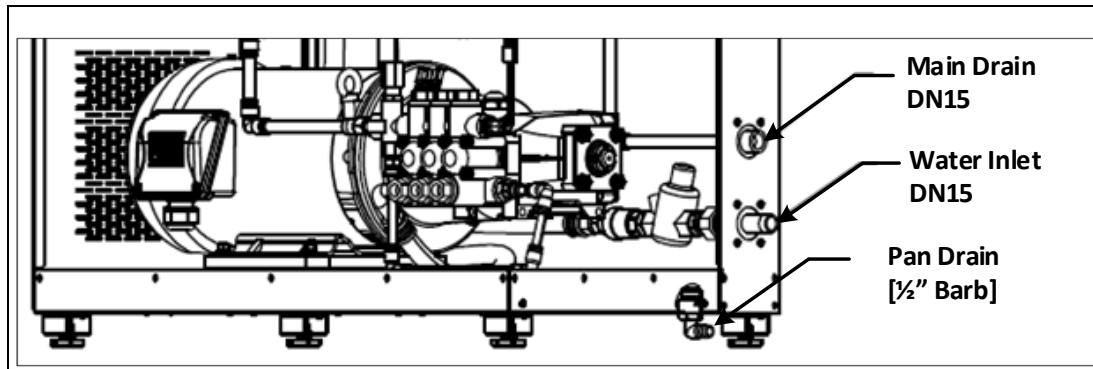

Illustration 9 - Water Connections for Pump Station



*Note: Do not over tighten the hose fittings as this may damage the seals.*

Table 8 - Water Supply and Drain Connection Specifications



Specification		All Models	
Water Supply	Water supply size	Male DN15	
	Minimum water supply pressure	2 bar	
	Maximum water supply pressure	4.8 bar	
	Minimum water supply temperature	3°C	
	Maximum water supply temperature	25°C	
	Water supply quality	Stainless Steel Pump:	5-20 µS/cm
	Brass Pump:	10-80 µS/cm	
	Drain outlet size	Female DN15	
	Pan drain outlet size	1/2" Barb	

## Water Supply

- Connect the female NPT connection of the water supply inlet of the humidifier to a high quality water source.
- The SKH4 requires high quality water to prevent scale build-up and clogging of the spray nozzles, resulting in frequent replacement of nozzles. Poor water quality is also damaging to the pump. Furthermore, most of the minerals contained in the water are sprayed into the air.
- Brass pumps are compatible with tap water, reverse osmosis (RO) and deionized water (DI), although RO water is preferable, in the conductivity range of 10-80  $\mu\text{S}/\text{cm}$ .
- Stainless steel pumps require high quality water, tap water will cause irreversible damage quickly. RO or DI water in the 5-20  $\mu\text{S}/\text{cm}$  conductivity range is recommended.
- If the supplied water is treated with reverse osmosis or deionization filtration, control the total dissolved solid contents in the water to be above the minimum recommended (see Table 8), as there is no need for ultra-pure water.

## High-Pressure Water Outlets

- High-pressure water outlets use a DN10 flexible high-pressure nylon hose (available upon request) connected to a push-to-connect 3/8" fittings with the respective stage and drain valves.
- Alternatively, stainless steel rigid piping with compression fittings or DN15 flexible high-pressure nylon with matching push-to-connect hose can also be used at the outlets.
- Neptronic offers the following adaptor fittings from the outlets of valves to start the distribution network:

Tube	Type	Dimension	Part Number	Illustration
Flexible Nylon Tube	Push to connect	O.D.3/8" (DN10)	SPH2550	
		O.D.1/2" (DN12)	SPH4008-13	
Stainless Steel Tube	Compression	O.D.3/8" (DN10)	SPH2520	
		O.D.1/2 (DN12)	SPH4008-41	

- (Optional) If using a remote valve panel (RVP), connect the RVP inlet manifold to a single outlet from the pump unit to minimize pressure losses. Connections are made using a DN10 or DN15 flexible high-pressure nylon hose or a high-pressure hydraulic hose or stainless steel rigid piping (available upon request). (See RVP section)



*Note: Ensure that the rating of the flexible hose is appropriate for the operating pressure (70bar).*

## Water Drain

- Connect a DN15 pipe (not supplied) to the female DN15 drain outlet to an open drain outlet.
- The pan drain is located below the base of the SKH4 pump station and is directed towards the main building open drain.
- The open drain pipe must have a minimum diameter of DN40.



**WARNING: Risk of flooding. Never connect the drains to a closed piping network.**

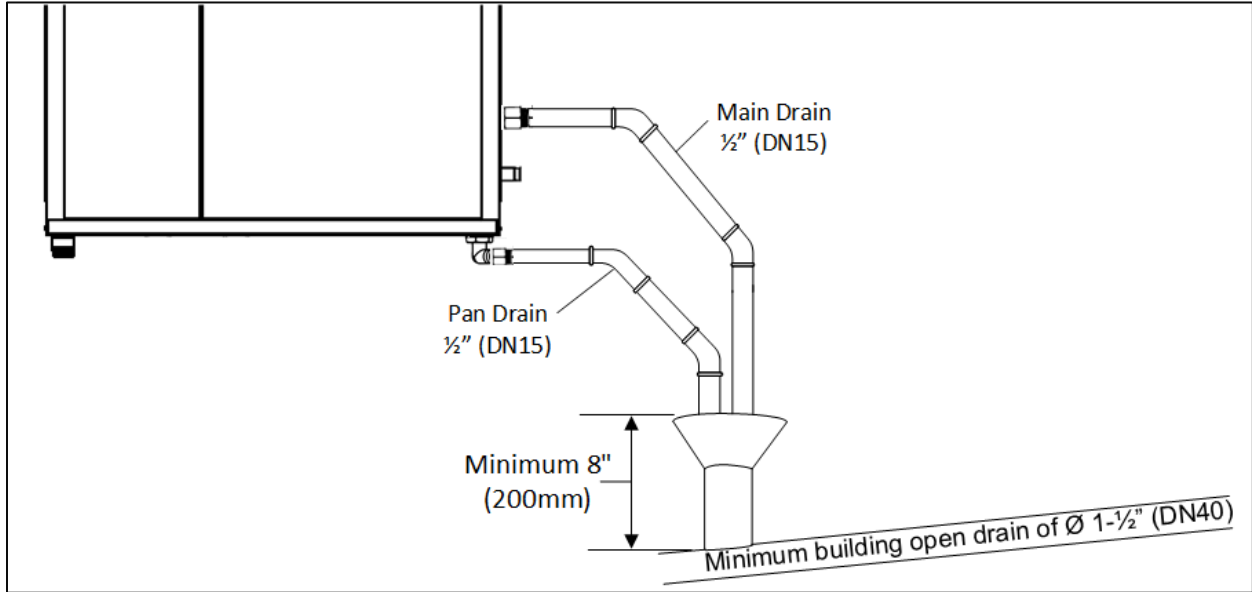

Illustration 10 - Water Drain Connections

## Step 3 – Power Supply Connections



**WARNING:** All work concerned with electrical installation **MUST** only be performed by skilled and qualified technical personnel, such as electricians or technicians with appropriate training. The customer is responsible for ensuring their suitability.



**WARNING:** Risk of electric shock. Isolate all power supplies before installation and maintenance of the SKH4 High-Pressure Atomizer or the RVP.



You **MUST** externally fuse all incoming power supplies for over current protection. Observe local codes and regulations concerning the provision of electrical installations.

The installation engineer must ensure the following:

- Use copper power conductors only.
- Ensure that the size of the power conductors is suitable for the maximum current supplied.
- Secure incoming power cables using a suitably sized cable gland.
- Secure each terminal connection with a cable ferrule.
- Do not use the SKH4 pump station's frame to connect to ground. The SKH4 pump station cabinet has a provision for the electrical ground.

### Power Supply Connections on SKH4 Pump Station

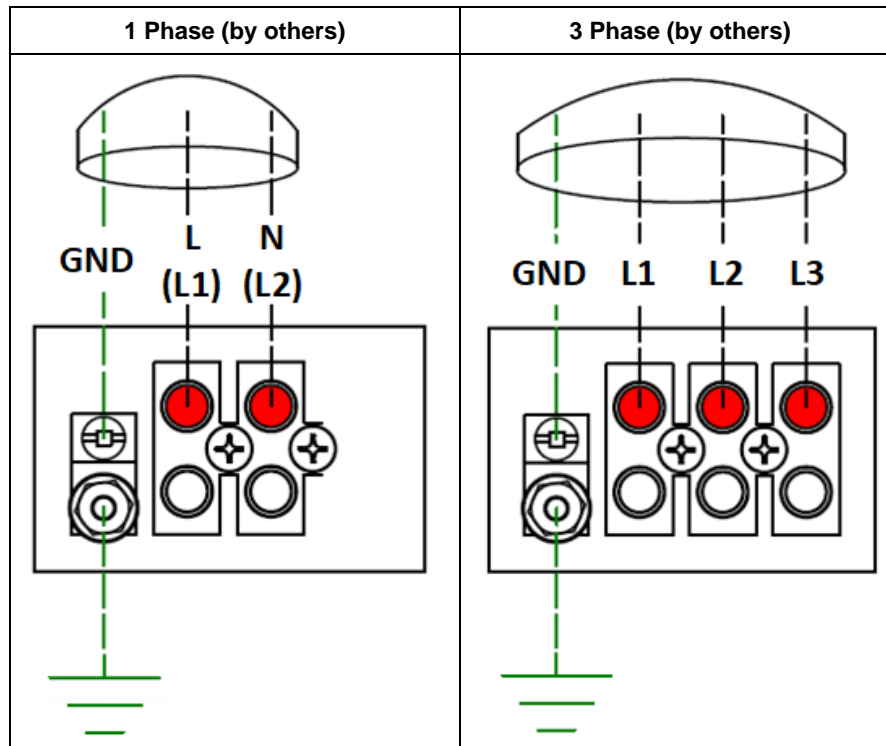

Illustration 11 - One and Three Phase Power Supply Connections

## Power Supply Knockout Holes Location on SKH4 Pump Station

Connect high power cable through the knockout holes provided on the unit. Alternative points are given depending on the installation constraints.

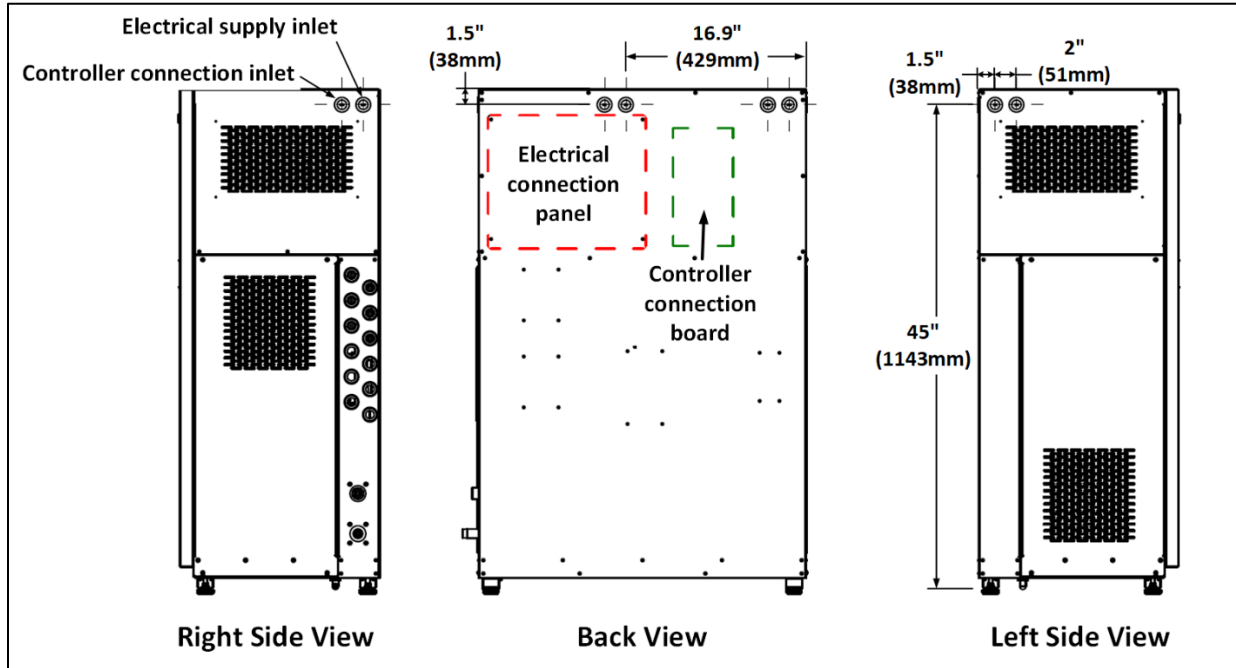

Illustration 12 - Power Supply Knockout Holes



## Step 4 – Electrical Control Connections



**WARNING:** All work concerned with electrical installation **MUST** only be performed by skilled and qualified technical personnel, such as electricians or technicians with appropriate training. The customer is responsible for ensuring their suitability.



**WARNING:** Risk of electric shock. Isolate all power supplies before installation and maintenance of the SKH4 High-Pressure Atomizer.

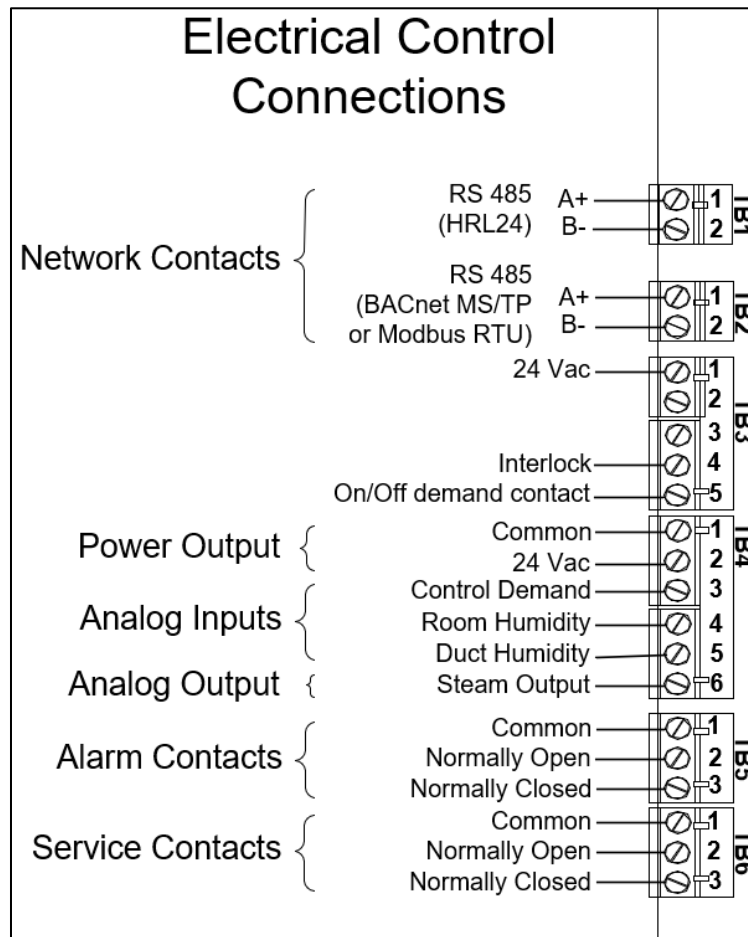

Illustration 13 - Electrical Control Connections

### Safety Contact Connections for Pump Unit

Available directly on the pump unit, this safety contact will interrupt all actions of the pump unit, for all zones.

- *Interlock.* Wire the switch on the PCB between terminals TB3 1&4. If this contact opens, the operation of the SKH4 unit stops all zones and an **Alarm** will be displayed. If the interlock is not used, install a jumper between terminals TB3 1&4.

### Safety Contact Connections Single Zone Without TRUB

- *Interlock.* Wire the switch on the PCB between terminals TB3 1&4. If this contact opens, the operation of the SKH4 unit stops all zones and an **Alarm** will be displayed. If the interlock is not used, install a jumper between terminals TB3 1&4.

## Safety Contact Connections per Zone from TRUB

Available on each TRUB, these will have an effect only the associated zone, other zones will continue their operation:

- *Airflow Switch (Activated option)*. Wire the contact on the TRUB between the recommended terminals TB2 2 (COM) & 3 (UI3). If this contact opens, the operation of the zone(s) will stop. The unit displays the Airflow switch as 'open' but will **not** generate an alarm. If spraying in-space, the airflow switch is not required. (Refer to the configuration menu)
- *High Limit Humidistat (Activated option)*. Wire the contact on the TRUB between the recommended terminals TB1 13 (COM) & 15 (UI2). If this contact opens, the operation of the zone(s) will stop, and an **Alarm** will be displayed. If spraying in-space, the high limit humidistat is not required.
- *Interlock*. Wire the switch on the TRUB between the recommended terminals TB2 2 (COM) & 4 (UI4). If this contact opens, the operation of the zone will stop and an **Alarm** will be displayed.

For more information, consult the TRUB documentation.

## Network Communication

If the control signal is from BACnet MS/TP or Modbus RTU network, connect terminals TB2 1&2 to the network (RS485 A+ & B).

If the control signal is from a network of one or multiple TRUB, connect terminals TB1 1&2 to the network (RS485 A+ & B-).

The network control signal(s) must be selected by accessing the *Control* sub-menu located in the *Installation* menu (see page 58). To setup the communication parameters, access the *Integration* menu (see page 41).



*Note: BACnet MS/TP is configured by default. To change the communication interface to Modbus RTU, access the NtwrkOption setting located in the Network sub-menu of the Integration menu (see page 41).*

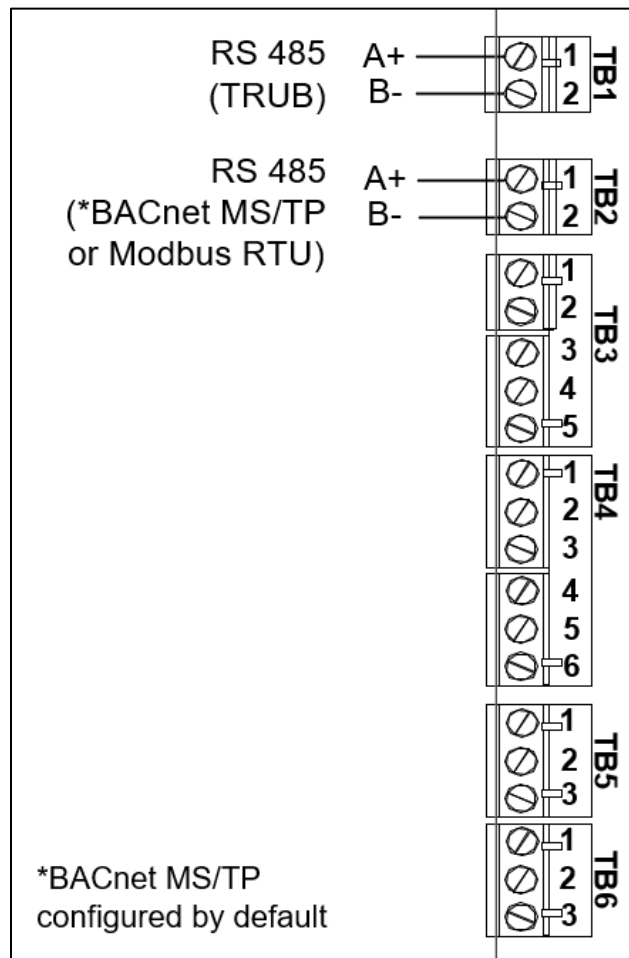

Illustration 14 - Network Communication Connections

### BACnet – Network

The SKH4 master pump station may use BACnet or Modbus protocols to communicate, either with an IP connection or MS/TP.

## Step 5 – Pump Controller Installation and Configuration

### User Interface

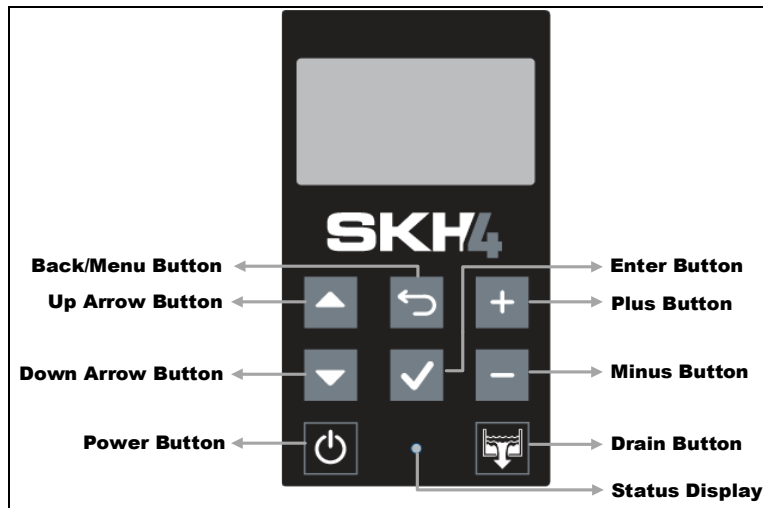













Illustration 15 - SKH4 Controller

### Controller Panel Features

The following are the features of the Control Panel and their description:

Table 9 - Humidifier Control Panel Description

Feature		Description
Status Display	 (Blue)	Indicates that the humidifier is turned on. The LED will begin blinking as the system is initializing.
	 (Red)	Indicates that the humidifier is issuing an alarm or warning and that the system must be verified.
	 (Off)	Indicates that the humidifier is turned off.
Power Button		The power button is used to turn the humidifier on or off. Must be pressed and held for 3 seconds to perform the related action, in order to prevent accidental activation. Even when the humidifier is powered off, the controller remains operational.
Drain Button		The drain button is used to manually activate the drain cycle. Must be pressed and held for 3 seconds to perform the related action, in order to prevent accidental activation. Even when the humidifier is powered off, a manual drain cycle may be initiated. <i>Once the manual drain cycle is completed, the system will automatically be powered off. To turn the humidifier back on, press and hold the power button.</i>
Up and Down Arrow Buttons	 	The up arrow button is used to scroll to the next menu item or parameter. The down arrow button is used to scroll to the previous menu item or parameter.
Plus and Minus Buttons	 	The plus button is used to increase the value of the displayed parameter. The minus button is used to decrease the value of the displayed parameter.
Back/Menu Button		The back/menu button is used to go to previous menu or to access the Main Menu page from the Idle Screen.
Enter Button		The enter button is used to advance to the next sub-menu, to access selected option or to confirm set parameter value.

## Idle Screen

When the controller is in operation, the unit displays the following information on the Idle Screen:

Table 10 - Idle Screen Display Description

Setting	Default	Range (* indicates no configuration; display only)	Description/Notes
Pressure:	Current value	* (min: 0 psi, max: 10000 psi)	Displays the current value of the pump pressure.
ControlState:	Current value	* (Off, Normal, LowLimit, HighLimit, NoAirFlow, Interlock)	Displays the current state of the safety control circuit and whether the circuit has been disconnected due to a safety switch.
State:	Current value	* (Off, Idle, LineRinse, TankRinse, Filling, Draining, Heating, Boiling, Alarm)	Displays the current state of operation of the humidifier.
ZonexDemand:	Current value	* (min: 0.00%, max: 100.00%)	Displays the value of demand for the selected zone.

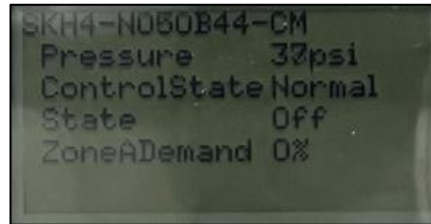

Illustration 16 - Idle Screen Display

## Menu Access

- From the Idle Screen, the Main Menu can be accessed by pressing the Back/Menu button, enabling access to the General menu.
- To view other menu options and perform configurations to the system, press Enter while on the Idle Screen to advance to the Login Screen, where a valid password must be entered.
- Four different passwords can be used, each granting access to an additional menu option depending on the access level assigned to the provided password.
- If a password of higher access is provided, all menu options accessible with the use of a lower-level password will also be unlocked.

Table 11 - Access Levels

Access Level	Password	Menu Unlocked	Description/Notes
1	None	General	Grants access to General menu.
2	2222	User	Grants access to General and User menus.
3	3322	Service	Grants access to General, User and Service menus.
4	4433	Installation	Grants access to General, User, Service and Installation menus.
5	5544	Integration	Grants access to General, User, Service, Installation and Integration menus.



*Note: To modify or retrieve lost passwords, please contact factory.*

## Configuration parameters

In the menu *Installation/quickConfig/Stage[ ]*, each stage needs to be defined. Input which zone (control signal) each stage is connected to and input the capacity (L/h) for the stage control. Input the drain valve associated with the stage valve (the two valves should form a loop with the nozzles in between).

The drain volume can be increased if the line is very long, in order to ensure depressurization of the line.

## Control function

**Ramp up:** In the menu *Installation/quickConfig/Zone[ ]/StgOpenDelay*, this parameter allows a user to add a delay between the opening of the stages, for each zone separately. When that time value is higher than zero, the smallest stage will open, followed by the second smallest after the delay parameterized. The output increases progressively, which results in less intense variation in the system, which results in the control being more precise and reduces the risk of overshooting during the startup process.

**Pulse settings:** In the menu *Installation/quickConfig/Stage[ ]*, the *MaxOnTime* and *PauseTime* features allow the user to make the stages pulse. This feature can be useful in order to shorten absorption distances by allowing a time pause between the addition of water in the air which eases the absorption. This parameter should only be used with multi stage zones, in order to prevent the short cycling of the pump and motor. If the humidification by pulse stops and starts the motor in a period shorter than 5 min, revise the pulse setting to prevent damages to the pump unit components.



**WARNING:** The parameters for setting the pulse frequency should be validated with a test in order to make sure the pump and motor do not start and stop too frequently within 5 minutes, as this may damage the pump or the electrical components.

## Control Profile Selection

In order to select the desired control profile, first determine the signal type to be used (by demand [external profile] or sensor [internal profile]). Next, determine whether the humidifier is going to be controlled via a *network* or by an *analog signal* from the following options based on the number of zones:

### Single Zone Operation

#### Control Profile – External Signal – Analog

The unit expects a demand signal in the form of a 0-10V, wired on the pump unit's control board, on pin TB4 3. The unit follows that demand directly and activates the respective valves in order to minimize the error between the output and the demand. This configuration requires a thermostat.

#### Control Profile – External Signal – Network

The unit expects a demand signal, coming from the network. Set the demand using the object *AV.138 Control Network Demand*. This configuration requires a thermostat and a BMS.

*Note: The main controller board inside of the pump unit needs be equipped with the option of network, either with the IP connection or the MS/TP connection. Both Modbus and BACnet protocols are supported.*

#### Control Profile – Internal Signal – Analog

The pump unit's control board receives a 0-10V signal from the setpoint reading and a room temperature/humidity input from a sensor through the control input on TB4 pin 3, and then calculates internally the PID (proportional, integral, and derivative) control responses and computes the desired outputs. This configuration requires temperature/humidity sensor(s). Refer to Table 12 - Complete List of Configurable Objects for complete list of configurable objects.

### Control Profile – Internal Signal – Network

The unit expects either a temperature demand signal (set using object AV.155 Control Network Demand and object AV.156 Room temperature setpoint) or a humidity demand signal (set using object AV.106 Room RH Network Reading and object AV.107 Room RH Setpoint), coming from the network and then calculates internally the PID (proportional, integral, and derivative) control responses and computes the desired outputs. This configuration requires temperature/humidity sensor(s) and a BMS. Refer to Table 12 - Complete List of Configurable Objects for complete list of configurable objects.

*Note: The main controller board inside of the pump unit needs be equipped with the option of network, either with the IP connection or the MS/TP connection. Both Modbus and BACnet protocols are supported.*

Table 12 - Complete List of Configurable Objects

PID Loop Configuration	
Control Profile	Configurable Objects
Internal Analog/Network Humidity	<ol style="list-style-type: none"> <li>1. AV.110 Room RH Demand Proportional Gain</li> <li>2. AV.111 Room RH Demand Integral Time</li> <li>3. AV.112 Room RH Demand Derivative Time</li> <li>4. AV.230 Room RH Demand Proportional Band</li> <li>5. AV.108 Room RH Unoccupied Setpoint</li> <li>6. AV.109 Room RH Vacant Setpoint</li> </ol>
Internal Network Temperature	<ol style="list-style-type: none"> <li>1. AV.159 Room Temperature Demand Proportional Gain.</li> <li>2. AV.160 Room temperature Demand Integral Time.</li> <li>3. AV.161 Room Temperature Demand Derivative Time.</li> <li>4. AV.174 Room Temp Demand Proportional Band.</li> <li>5. AV.157 Room Temperature Unoccupied Setpoint.</li> <li>6. AV.158 Room Temperature Vacant Setpoint.</li> </ol>

## Multi-Zones Operation

### Control Profile – External Signal – Network

Same description as the single zone operation.

### TRUB Controller

When using a TRUB thermostat, connect the Pump station PCB to the TRUB. For more details, consult the TRUB documentation.

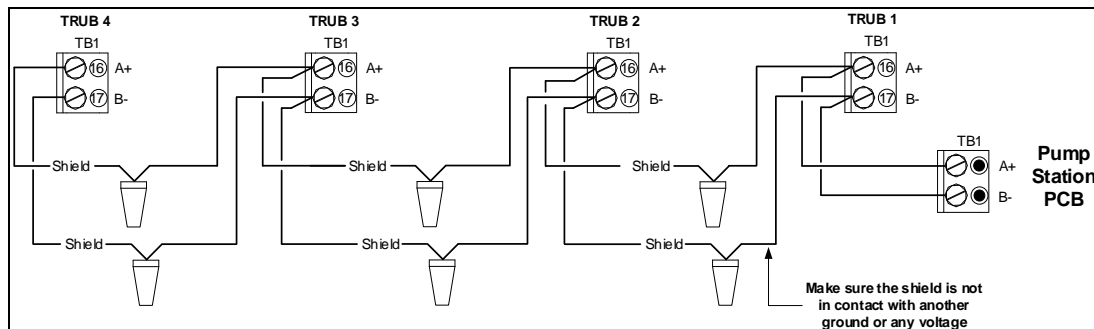

Illustration 17 - Pump Communication Shield Wiring



**Menu - General** [Level 1 - No password required]

Press the back/menu button from the Idle Screen to access the General menu.

Sub-Menu	Setting	Default	Range (* indicates no configuration; display only)	Description/Notes	
Status	SysPowerState:	Off	* (Off, On)	Displays the status of the system power state.	
	Airflow:	Closed	* (Closed, Open)	Displays the status of the airflow switch. If <i>Open</i> is displayed, it indicates that the airflow is not detected by the air pressure switch.	
	SupplyHighLimit:	Closed	* (Closed, Open)	Displays the status of the high limit contact. If <i>Open</i> is displayed, it indicates that the humidity level has exceeded the setpoint on the high limit humidistat.	
	Interlock:	Closed	* (Closed, Open)	Displays the status of the interlock. If <i>Open</i> is displayed, it indicates that the humidifier is stopped as a result of the interlock safety being open.	
	Pressure:	<i>Current value</i>	* (min: 0 psi, max: 10000 psi)	Displays the current value of the pump pressure.	
	ControlSate:	Off	* (Off, On)	Displays the status of the control state.	
	State:	<i>Current value</i>	* (Off, Idle, Spraying, Draining, Alarm)	Displays the current state of operation of the humidifier.	
	<b>ZoneA to F</b>		<b>[6]</b>		
		ZoneADemand to D:	50%	* (min: 0%, max: 100%)	Displays the value of demand for the zone.
		Temperature:	68.0°F [20.0°C]	* (min: -40.0°F, max: 302.0°F) * [min: -40.0°C, max: 150.0°C] Units: C, F	Displays the value of temperature for the zone.
		Humidity:	0.00%RH	min: 0.00%RH max: 100.00%RH Units: %RH	Displays the valve humidity for the zone.
	Control:	Off	* (Off, Normal, Airflow, SupplyHighLimit, Interlock)	Displays the current state of the safety control circuit and whether the circuit has been disconnected due to a safety switch.	
	Occupancy:	Occupied	* (Occupied, Unoccupied, Vacant, Off)	Displays the current occupancy state.	
Control	RoomTempDemand:	<i>Current value</i>	* (min: 0%, max: 100%)	Displays the room temperature demand value. <b>Only appears if there is a single zone and ControlProfile is set to an internal control mode or DemandSrc is set to TempRoomDemand.</b>	
	TempSupplyHLDemand:	<i>Current value</i>	* (min: 0%, max: 100%)	Displays the supply high limit temperature demand value. <b>Only appears if there is a single zone and ModHLProfile is set to an internal control mode or HighLimitSrc is set to TempSupplyHLDemand or if there's a single zone.</b>	
	RoomRHDemand:	<i>Current value</i>	* (min: 0%, max: 100%)	Displays the room humidity demand value. <b>Only appears if there is a single zone and ControlProfile is set to an internal control mode or DemandSrc is set to HumRoomDemand.</b>	
	RHSupplyHLDemand:	<i>Current value</i>	* (min: 0%, max: 100%)	Displays the supply high limit humidity demand value. <b>Only appears if there is a single zone and ModHLProfile is set to an internal control mode or HighLimitSrc is set to RHSupplyHLDemand.</b>	





<b>Physical IO</b>	AirFlow:	Closed	* (Closed, Open)	Displays the status of the airflow switch. If <i>Open</i> is displayed, it indicates that the airflow is not detected by the air pressure switch.
	SupplyHighLimit:	Closed	* (Closed, Open)	Displays the status of the high limit contact. If <i>Open</i> is displayed, it indicates that the humidity level has exceeded the setpoint on the high limit humidistat.
	Interlock:	Closed	* (Closed, Open)	Displays the status of the interlock. If <i>Open</i> is displayed, it indicates that the humidifier is stopped as a result of the interlock safety being open.
	Pressure:	<i>Current value</i>	* (min: 0 psi, max: 10000 psi)	Displays the value of the pump pressure.
	InPressSwitch:	Low	*(Low, Ok)	Displays the status of inlet pressure switch.
	ControllInput:	<i>Current value</i>	* (min: 0%, max: 100%)	Displays the current control input humidity reading.
	ControllInput:	<i>Current value</i>	* (min: -40.0°F, max: 302.0°F) * [min: -40.0°C, max: 150.0°C] Units: C, F	Displays the current control input temperature reading.
	RoomTemp:	<i>Current value</i>	* (min: -40.0°F, max: 302.0°F) * [min: -40.0°C, max: 150.0°C] Units: C, F	Displays the room temperature reading value. <b>(Only appears if <i>ControlProfile</i> is set to <i>InternAnalog</i> or <i>RoomRHsrc</i> is set to <i>RoomRH</i>.)</b>
	SupplyHLRH:	<i>Current value</i>	* (min: 0%, max: 100%)	Displays the supply high limit humidity reading value. <b>(Only appears if <i>ControlProfile</i> is set to <i>InternAnalog</i> or <i>RoomRHsrc</i> is set to <i>RoomRH</i>.)</b>
	SupplyHLTemp:	<i>Current value</i>	* (min: -40.0°F, max: 302.0°F) * [min: -40.0°C, max: 150.0°C] Units: C, F	Displays the supply high limit temperature reading value. <b>(Only appears if <i>ModHLPProfile</i> is set to <i>InternAnalog</i> or <i>SupplyHLReadingSrc</i> is set to <i>SupplyHLRH</i>.)</b>
	WaterTemp:	<i>Current value</i>	* (min: 32.0°F, max: 257.0°F) * [min: 0.0°C, max: 125.0°C] Units: C, F	Displays the temperature of water in the evaporation chamber.
	WtrLeakDet:	Ok	* (Ok, Leak)	Displays whether a water leak has been detected. If <i>Leak</i> is displayed, it indicates that there is a leak within the water line.
	DriveEnable:	Off	* (Off, On)	Displays the status of the drive enable.
	DriveStatus:	Ok	* (Ok, Fault)	Displays the status of drive.
	DriveSignal:	0.000V	* (min: 0.000V, max: 10.000V)	Displays the value of the drive signal.
	MotorSpeed:	<i>Current value</i>	* (min: 0%, max: 100%)	Displays the value of the motor speed.
	Contactorpump:	Off	* (Off, On)	Displays the status of the contactor pump.
	AlarmRelay:	Off	* (Off, On)	Displays the status of the alarm warning relay.
	RelayFuse:	<i>Normal</i>	* (Normal, Blown Fuse)	Displays the current status of the PCB fuse. If <i>Blown Fuse</i> is displayed, the fuse must be replaced.
	ServiceRelay:	<i>Current value</i>	* (Off, On)	Displays the status of the service warning relay.
Valve1	Off	* (Off, On)	Displays the status of the valve 1.	
Valve2	Off	* (Off, On)	Displays the status of the valve 2.	
Valve3	Off	* (Off, On)	Displays the status of the valve 3.	



Physical IO	Valve4	Off	* (Off, On)	Displays the status of the valve 4.
	Valve5	Off	* (Off, On)	Displays the status of the valve 5.
	Valve6	Off	* (Off, On)	Displays the status of the valve 6.
	Valve7	Off	* (Off, On)	Displays the status of the valve 7.
	Valve8	Off	* (Off, On)	Displays the status of the valve 8.
	Valve9	Off	* (Off, On)	Displays the status of the valve 9.
	Valve10	Off	* (Off, On)	Displays the status of the valve 10.
	Valve11	Off	* (Off, On)	Displays the status of the valve 11.
	Valve12	Off	* (Off, On)	Displays the status of the valve 12.
System	SysStatus:	Operational	* (Operational, Operational Read-Only, Download required, Download in progress, Non-operational, Backup in progress)	Displays the current system status.
	Vendor:	Neptronic	*	Displays the name of the vendor of the product. (Always Neptronic)
	Model:	-	*	Displays the humidifier model name.
	AppVersion:	1.02.240308	*	Displays the current application software version.
	SerialNo:	-	*	Displays the serial number of the humidifier.
	Profile:	-SKH4 Controller	*SKH4 Controller	Displays a short profile for the configured device.
	MCULoad:	<i>Current value</i>	* (min: 0%, max: 100%)	Displays the current microcontroller load.
	MemoryLoad:	<i>Current value</i>	* (min: 0%, max: 100%)	Displays the current memory load.
	Runtime:	<i>Current value</i>	* (min: 0 sec, max: 999999999 sec)	Displays the number of seconds that the system has been powered on. This value is reset every time the system is shut off.
ResetReason:	None	* (None, BOR, Pin, POR, Soft, IWDG, WWDG, LPWR, Unknown)	Displays the reason for the previous system reset: <i>None = No Reset; BOR = Brownout Reset; Pin = Pin Reset (using PCB Reset Button); POR = Power-on Reset; Soft = Software Reset; IWDG = Independent Watchdog; WWDG = Windowed Watchdog; LPWR = Low Power Reset; Unknown = Unknown Cause</i>	

### Menu - User Settings [Level 2 - Requires level 2 (or higher) password in order to access]

Sub-Menu	Setting	Default	Range	Description/Notes	
Command	OccupSchedule:	-	00:00 Monday to Sunday Event 1 to Event 6	Create a customized occupancy schedule with up to six events per day.	
	DrainSchedule:	-	00:00 Monday to Sunday Event 1 to Event 6	Create a customized draining schedule with up to six events per day.	
Control	<b>RoomTempDemandLoop [3]</b>			<b>Only appears if there is a single zone and ControlProfile is set to an internal control mode or DemandSrc is set to TempRoomDemand.</b>	
		OccStp:	40.0%	min: 0.0%, max: 100.0%	Define the room temperature demand setpoint value used during <i>Occupied</i> state. <b>Only appears if there is a single zone and RoomTempDemandLoopStptSrc is set to Internal.</b>
		UnocStp:	30.0%	min: 0.0%, max: 100.0%	Define the room temperature demand setpoint value used during <i>Unoccupied</i> state.
		VacantStp:	20.0%	min: 0.0%, max: 100.0%	Define the room temperature demand setpoint value used during <i>Vacant</i> state.
	<b>TempSupplyHLLoop [3]</b>			<b>Only appears if there is a single zone and ModHLProfile is set to an internal control mode or HighLimitSrc is set to TempSupplyHLLDemand.</b>	
		OccStp:	80.0%	min: 0.0%, max: 100.0%	Define the supply high limit temperature demand setpoint value during <i>Occupied</i> state. <b>Only appears if there is a single zone and TempSupplyHLLoopStptSrc is set to Internal.</b>
		UnocStp:	30.0%	min: 0.0%, max: 100.0%	Define the supply high limit temperature demand setpoint value used during <i>Unoccupied</i> state.
		VacantStp:	20.0%	min: 0.0%, max: 100.0%	Define the supply high limit temperature demand setpoint value used during <i>Vacant</i> state.
	<b>RoomRHDemandLoop [3]</b>			<b>Only appears if there is a single zone and ControlProfile is set to an internal control mode or DemandSrc is set to HumRoomDemand.</b>	
		OccStp:	40.0%	min: 0.0%, max: 100.0%	Define the room humidity demand setpoint value used during <i>Occupied</i> state. <b>Only appears if there is a single zone and RoomRHDemandLoopStptSrc is set to Internal.</b>
		UnocStp:	30.0%	min: 0.0%, max: 100.0%	Define the room humidity demand setpoint value used during <i>Unoccupied</i> state.
		VacantStp:	20.0%	min: 0.0%, max: 100.0%	Define the room humidity demand setpoint value used during <i>Vacant</i> state.
	<b>RHSupplyHLLoop [3]</b>			<b>Only appears if there is a single zone and ModHLProfile is set to an internal control mode or HighLimitSrc is set to RHSupplyHLLDemand.</b>	
		OccStp:	80.0%	min: 0.0%, max: 100.0%	Define the supply high limit humidity demand setpoint value during <i>Occupied</i> state. <b>Only appears if there is a single zone and RHSupplyHLLoopStptSrc is set to Internal.</b>
		UnocStp:	30.0%	min: 0.0%, max: 100.0%	Define the supply high limit humidity demand setpoint value used during <i>Unoccupied</i> state.
	VacantStp:	20.0%	min: 0.0%, max: 100.0%	Define the supply high limit humidity demand setpoint value used during <i>Vacant</i> state.	
System	UTCOffset: -300min	-300min	min: -720min, max: 720min	Configure the value of the UTC offset.	
	DaylightSavings: No	No	No, Yes	Select whether to enable daylight savings or not.	



<b>System</b>	LocalDateTime:	YYYY-MM-DD 00:00:0		Configure the current date and time.
<b>Interface</b>	<b>LocalDisplay [5]</b>			
	BacklightLvl:	25%	min: 0%, max: 100%	Select the backlight level of the LCD screen.
	Contrast:	10%	min: 0%, max: 30%	Select the contrast level of the LCD screen.
	MenuTimeout:	300sec	min: 30sec, max: 1800sec	Set the value of the local menu timeout.
	KeypadBuzzer	Inactive	Inactive, Active	Select whether to enable or disable the key press sound.
	Language:	English	English, French, Spanish	Select the device language.
	Units:	Imperial	Metric, Imperial	Select whether to use a metric or imperial system of units for the local device.



**Menu - Service** [Level 3 - Requires level 3 (or higher) password in order to access]

Sub-Menu	Setting	Default	Range (* indicates no configuration; display only)	Description/Notes
Status	OnTime:	0.00hr	*	Displays the total operating time of the unit.
	ServOnTime:	0.00hr	*	Displays the operating time of the unit since the last servicing.
	<b>Stage1 to 6 [5]</b>			
	CycleCount:	0	*	Displays the total cycle count of the stage valve.
	RunTime:	0.00hr	*	Displays the total runtime of the unit.
	OnTime:	0.00hr	*	Displays the total operating time of the unit.
	IdleTime:	0.00hr	*	Displays the amount of time the humidifier can remain in standby mode until an automatic drain cycle is performed.
	DrainTime:	0sec	*	Displays the frequency of the drain cycle. In general, a more frequent drain cycle is required as the water hardness level rises. The drain cycle setting does not affect the AFEC system.
	<b>Drain1 to 6 [1]</b>			
CycleCount:	0	*	Displays the total cycle count of the drain valve.	
Diagnostic	DiagState:	* (Off, On)	Displays the diagnostic state	Set the status of the diagnostic state.
	DiagCmd:	* (Spray, Drain)	Displays the diagnostic command	Set the status of the diagnostic command.
	DiagPeriod:	* (min: 1min, max: 60min)	Displays the maximum diagnostic time to remain active	Set the value for the diagnostic period.
	DiagTimer:	* (min: 0sec, max: 3600sec)	Displays the remaining diagnostic time to remain active	Set the value of the diagnostic timer.
	Stage1Enable:	* (No, Yes)	Displays whether diagnostic stage 1 is active	Set the status of the stage 1 diagnostic enable.
	Stage2Enable:	* (No, Yes)	Displays whether diagnostic stage 2 is active	Set the status of the stage 2 diagnostic enable.
	Stage3Enable:	* (No, Yes)	Displays whether diagnostic stage 3 is active	Set the status of the stage 3 diagnostic enable.
	Stage4Enable:	* (No, Yes)	Displays whether diagnostic stage 4 is active	Set the status of the stage 4 diagnostic enable.
	Stage5Enable:	* (No, Yes)	Displays whether diagnostic stage 5 is active	Set the status of the stage 5 diagnostic enable.
	Stage6Enable:	* (No, Yes)	Displays whether diagnostic stage 6 is active	Set the status of the stage 6 diagnostic enable.
Command	Request:	None	None, ResetAlarms, Drain, ResetServCnt	Perform one of the following actions for the humidifier: reset warning alarms, initiate a drain cycle, reset service counters.



**Menu - Installation** [Level 4 - Requires level 4 (or higher) password in order to access]

Sub-Menu	Setting	Default	Range (* indicates no configuration; display only)	Description/Notes
Import User Config				Import all the controller configuration values onto the SD card. A SD card must be inserted in order to import the values.
Import User Config				Export all the controller configuration values onto the SD card. A SD card must be inserted in order to export all the values.
Quick Config	<b>ZoneA to D [1]:</b>			
	StgOpenDelay:	0	min: 0, max: 30	Set the value of the stage open delay.
	<b>Stage1 to 6 [6]:</b>			
	Capacity:	500l/h	min:0l/h, max: 3000l/h	Set the value of the capacity.
	Zone:	ZoneA	ZoneA, ZoneB, ZoneC, ZoneD, ZoneE, ZoneF	Select the zone.
	Drain:	Drain11	Drain7, Drain8, Drain9, Drain10, Drain11, Drain12	Select the drain.
	MaxOnTime:	0sec	min: 0sec, max: 1200sec	Set the maximum value of the operating time of the unit.
	PauseTime:	15sec	min: 0sec, max: 1200sec	Set the value of the pause time of the unit.
Control	DrainVolume:	10l	min: 0l, max: 9999999l	Set the volume of water that is drained from the chamber.
	ControlProfile:	ExternAnalog	ExternAnalog, ExternNetwork, InternAnalog, InternNetwork, TRUB, Custom	Select a preconfigured control mode profile for the modulating humidity demand. Select the <i>Custom</i> option to configure individual settings. <b>(Network option only applicable for BACnet models.)</b>
	ModHHLProfile:	Disabled	Disabled, ExternAnalog, ExternNetwork, InternAnalog, InternNetwork, Custom	Select a preconfigured control mode profile for the modulating high limit demand. Select the <i>Custom</i> option to configure individual settings. <b>(Network option only applicable for BACnet models.)</b>
	<b>UnitControl [4]</b>			
	NtwkTimeout:	900sec	min: 1sec, max: 900sec	Define the amount of time the humidifier may attempt to connect to the BACnet or Modbus network before it stops operating due to a communication error. <b>(Only appears if there is a single zone and ControlProfile and ModHHLProfile are set to InternNetwork or ExternNetwork.)</b>
	DemandSrc:	None	None, ControllInput, HumRoomDemand, Network, TempRoomDemand	Select the humidity control demand source for modulating humidifiers. <b>(Network option only applicable for BACnet models.)</b>
	HighLimitSrc:	None	None, ControllInput, RHSupplyHLDemand, Network, TempSupplyHLDemand	Select the humidity control high limit source for modulating humidifiers. <b>(Network option only applicable for BACnet models.)</b>
	BinDemandSrc:	None	None, BinaryExtDemand	Select the humidity control demand source for On/Off humidifiers.
	<b>RoomTempDemandLoop [6]</b>			
	PropGain:	20.0	min: 1.0, max: 200.0	Set the value of the room demand proportional gain.



<b>Control</b>	ITime:	0.0sec	min: 0.0sec, max: 900.0sec	Set the value of the room demand integral time.	
	DTime:	0.0sec	min: 0.0sec, max: 60.0sec	Set the value of the room demand derivative time.	
	PropBand:	5.0%	min: 1.0%, max: 100.0%	Set the value of the room demand proportional band.	
	TempSrc:	None	None, TempRoom, Network, HRL	Select the reading source for the room temperature demand. <b>(Network option only applicable for BACnet models.)</b>	
	StptSrc:	None	None, Internal, ControllInput	Select the room demand setpoint source.	
	<b>TempSupplyHLLoop [6]</b>				<b>Only appears if ModHLProfile is set to an internal control mode and HighLimitSrc is set to TempSupplyHLDemand.</b>
	PropGain:	10.0	min: 1.0, max: 200.0	Set the value of the supply high limit demand proportional gain.	
	IntgrlTime:	0.0sec	min: 0.0sec, max: 900.0sec	Set the value of the supply high limit demand integral time.	
	DrvtveTime:	0.0sec	min: 0.0sec, max: 60.0sec	Set the value of the supply high limit demand derivative time.	
	ProbBand:	10.0%	min: 1.0%, max: 100.0%	Set the value of the supply high limit demand proportional band.	
	TempSrc:	None	None, SupplyHLTemp, Network	Select the reading source for the supply high limit temperature demand. <b>(Network option only applicable for BACnet models.)</b>	
	StpntSrc:	None	None, Internal, ControllInput	Select the supply high limit demand setpoint source.	
	<b>RoomRHDemandLoop [6]</b>				<b>Only appears if ControlProfile is set to an internal control mode and DemandSrc is set to HumRoomDemand.</b>
	PropGain:	20.0	min: 1.0, max: 200.0	Set the value of the room demand proportional gain.	
	ITime:	0.0sec	min: 0.0sec, max: 900.0sec	Set the value of the room demand integral time.	
	DTime:	0.0sec	min: 0.0sec, max: 60.0sec	Set the value of the room demand derivative time.	
	PropBand:	5.0%	min: 1.0%, max: 100.0%	Set the value of the room demand proportional band.	
	RHSrc:	None	None, RoomRH, Network, HRL	Select the reading source for the room humidity demand. <b>(Network option only applicable for BACnet models.)</b>	
	StptSrc:	None	None, Internal, ControllInput	Select the room demand setpoint source.	
	<b>RHSupplyHLLoop [6]</b>				<b>Only appears if ModHLProfile is set to an internal control mode and HighLimitSrc is set to RHSupplyHLDemand.</b>
	PropGain:	10.0	min: 1.0, max: 200.0	Set the value of the supply high limit demand proportional gain.	
	IntgrlTime:	0.0sec	min: 0.0sec, max: 900.0sec	Set the value of the supply high limit demand integral time.	
	DrvtveTime:	0.0sec	min: 0.0sec, max: 60.0sec	Set the value of the supply high limit demand derivative time.	
	ProbBand:	10.0%	min: 1.0%, max: 100.0%	Set the value of the supply high limit demand proportional band.	
	RHSrc:	None	None, SupplyHLRH, Network	Select the reading source for the supply high limit temperature demand. <b>(Network option only applicable for BACnet models.)</b>	
	StpntSrc:	None	None, Internal, ControllInput	Select the supply high limit demand setpoint source.	
	<b>ControllInput [6]</b>				



<b>Physical IO</b>	Signal:	0.000V	* (min: 0.000V, max: 15.000V)	Displays the value of the control demand analog input signal.	
	ControlInput:	0.0%	* (min: 0.0%, max: 100.0%)	Displays the actual value of the control demand analog input.	
	Min:	0.0%	min: 0.0%, max: 100.0%	Set the minimum value of the control demand analog input.	
	Max:	100.0%	min: 0.0%, max: 100.0%	Set the maximum value of the control demand analog input.	
	Bias:	0.0%	min: -10.0%, max: 10.0%	Set the bias value for the control demand analog input.	
	SignalType:	0-10Vdc	0-10Vdc, 2-10Vdc, 4-20mA, 0-20mA	Select the signal type for the control demand analog input.	
	<b>RoomRH [6]</b>				
	Signal:	0.000V	* (min: 0.000V, max: 15.000V)	Displays the value of the room humidity analog input signal.	
	RoomRH:	0.0%	* (min: 0.0%, max: 100.0%)	Displays the actual value of the room humidity analog input.	
	Min:	0.0%	min: 0.0%, max: 100.0%	Set the minimum value of the room humidity analog input.	
	Max:	100.0%	min: 0.0%, max: 100.0%	Set the maximum value of the room humidity analog input.	
	Bias:	0.0%	min: -10.0%, max: 10.0%	Set the bias value for the room humidity analog input.	
	SignalType:	0-10Vdc	0-10Vdc, 2-10Vdc, 4-20mA, 0-20mA	Select the signal type for the room humidity analog input.	
	<b>SupplyHLRH [6]</b>				
	Signal:	0.000V	* (min: 0.000V, max: 15.000V)	Displays the value of the duct or supply high limit humidity analog input signal.	
	SupplyHLRH:	0.0%	* (min: 0.0%, max: 100.0%)	Displays the actual value of the duct or supply high limit humidity analog input.	
	Min:	0.0%	min: 0.0%, max: 100.0%	Set the minimum value of the duct or supply high limit humidity analog input.	
	Max:	0.0%	min: 0.0%, max: 100.0%	Set the maximum value of the duct or supply high limit humidity analog input.	
	Bias:	0.0%	min: -10.0%, max: 10.0%	Set the bias value for the duct or supply high limit humidity analog input.	
	SignalType:	0-10Vdc	0-10Vdc, 2-10Vdc, 4-20mA, 0-20mA	Select the signal type for the duct or supply high limit humidity analog input.	
	<b>SupplyHLTemp [6]</b>				
	Signal:	0.000V	* (min: 0.000V, max: 15.000V)	Displays the value of the duct or supply high limit temperature analog input signal.	
	SupplyHLTemp:	68.0°F [20.0°C]	* (min: -40.0°F, max: 30-2.0°F) * [min: -40.0°C, max: 150.0°C] Units: C, F	Displays the actual value of the duct or supply high limit temperature analog input.	
	Min:	32.0°F [0.0°C]	* (min: -40.0°F, max: 30-2.0°F) * [min: -40.0°C, max: 150.0°C] Units: C, F	Set the minimum value of the duct or supply high limit temperature analog input.	
	Max:	104.0°F [40.0°C]	* (min: -40.0°F, max: 30-2.0°F) * [min: -40.0°C, max: 150.0°C] Units: C, F	Set the maximum value of the duct or supply high limit temperature analog input.	
	Bias:	0.00Δ°F [0.00Δ°C]	min: -18.00Δ°F, max: 18.00Δ°F [min: -10.00Δ°C, max: 10.00Δ°C] Units: Δ°C, Δ°F	Set the bias value for the duct or supply high limit temperature analog input.	





Physical IO	SignalType:	0-10Vdc	0-10Vdc, 2-10Vdc, 4-20mA, 0-20mA	Select the signal type for the duct or supply high limit temperature analog input.
	<b>RoomTemp [6]</b>			
	Signal:	0.000V	* (min: 0.000V, max: 15.000V)	Displays the value of the room temperature analog input signal.
	RoomTemp:	68.0°F [20.0°C]	* (min: -40.0°F, max: 30-2.0°F) * [min: -40.0°C, max: 150.0°C] Units: C, F	Displays the actual value of the room temperature analog input.
	Min:	32.0°F [0.0°C]	* (min: -40.0°F, max: 30-2.0°F) * [min: -40.0°C, max: 150.0°C] Units: C, F	Set the minimum value of the room temperature analog input.
	Max:	104.0°F [40.0°C]	* (min: -40.0°F, max: 30-2.0°F) * [min: -40.0°C, max: 150.0°C] Units: C, F	Set the maximum value of the room temperature analog input.
	Bias:	0.00Δ°F [0.00Δ°C]	min: -18.00Δ°F, max: 18.00Δ°F [min: -10.00Δ°C, max: 10.00Δ°C] Units: Δ°C, Δ°F	Set the bias value for the room temperature analog input.
SignalType:	0-10Vdc	0-10Vdc, 2-10Vdc, 4-20mA, 0-20mA	Select the signal type for the room temperature analog input.	
System	ResetFactory:	No	No, Yes	Select Yes in order to reset the humidifier back to its original factory configuration settings. <b>WARNING: There is no way to recover previous configurations once the device has been reset.</b>
Extended Config	InstallationDate:	YYYY/M M/DD		Set the device installation date.
	AlarmBuzzer:	Disabled	Normal, Disabled	Select whether to enable or disable the alarm buzzer sound whenever there is a system warning. This will not affect the Status Display LED.
	SysLogLevel:	Debug	None, Emergency, Alert, Critical, Error, Warning, Notice, Info, Debug	Select the type of information to be stored on log file. <b>(The humidifier must be connected to an SD card.)</b>
	IdleDrainTime	8hr	min: 1hr, max: 72hr	Set the drain time interval.
	CtrlSource:	Pump Board	Zone controller, Pump Board, BMS	Select the control source.
	PowerUpDrain	Off	Off, On	Select Yes to perform drain on Power Up
	CoolDrainMode	Off	Off, TimeLatch	Select the control mode for the cooling drain.
	CoolDrainTimer	30min	Min: 0min, max:60	Set the value of the cool drain timer.
	WatLoTempAlarm:	Alarm	Alarm, Warning	Select the status of the low water temperature alarm.
	ServInterval:	1000hr	min: 500hr, max: 3000hr	Set the time of operation before the humidifier calls for servicing.
	RunWhileServiceAlarm :	Allowed	NotAllowed, Allowed	Select whether to enable the unit to continue producing steam, even when it is due for servicing. When set to <i>Allowed</i> , the unit will continue operating even when a service alarm is active.
	ZoneCommunicationT	5sec	min: 0sec, max: 600sec	Set the wait time for the humidifier to try and reconnect to the TRUB. <b>Only appears if the ControlProfile is set to an external control mode and is connected to a TRUB.</b>
	ZoneAMAC:	1	min: 0, max: 127	Set the value of the MAC address for zone A.
	ZoneBMAC:	2	min: 0, max: 127	Set the value of the MAC address for zone B.
ZoneCMAC:	3	min: 0, max: 127	Set the value of the MAC address for zone C.	
ZoneDMAC:	4	min: 0, max: 127	Set the value of the MAC address for zone D.	

**Menu - Integration [Level 5 - Requires level 5 password in order to access]**

Sub-Menu	Setting	Default	Range (* indicates no configuration; display only)	Description/Notes
<b>Network</b>	NtwrkOption:	BACnet	BACnet, Modbus	Select whether to connect to a BACnet MS/TP or Modbus RTU communication interface on terminal TB2 of the humidifier PCB.
	<b>Device [4]</b>			
	DeviceName:	-		Establish a name for the device.
	Location:	-		Establish a designated location for the unit.
	Description:	-		Establish a brief description for the unit.
	DeviceInstance:	0153001 (0x000255a9)		Define the device instance value.
	<b>HTTPServer [1]</b>			
	HttpServerUnits:	Imperial	Metric, Imperial	Select whether to use a metric or imperial system of units for the web server.
	<b>BACnetServer [3]</b>			
	<b>For models connected to the BACnet network.</b>			
	Language:	English	English, French, Spanish	Select the language for the BACnet server.
	ListMode:	Integrator	Integrator, Advanced, Factory	Select the category of BACnet objects to display.
	Units:	Imperial	Metric, Imperial	Select whether to use a metric or imperial system of units for the BACnet server.
	<b>BACnetMSTP [10]</b>			
	<b>Only appears if NtwrkOption is set to BACnet.</b>			
	MaxMaster:	127	min: 1, max: 127	Configure MaxMaster value to increase network efficiency when there are less than 127 devices on the network. For optimal efficiency, set value to the highest MAC address in the MS/TP network.
	MaxInfoFrames:	1	min: 1, max: 100	Configure the maximum number of information messages the controller may transmit, before it must pass the token to the next controller.
	AutoBaud:	Yes	No, Yes	Enable or disable automatic baud rate detection.
	BaudRate:	38400	9600, 19200, 38400, 76800	Select the baud rate for data transfer.
	MAC:	001		Set the MS/TP network MAC address.
	RxValid:	0	*	Displays information on the received communication frames for troubleshooting purposes.
	RxInvalid:	0	*	
	RxLost:	0	*	
	Tx:	0	*	Displays information on the transmitted communication frames for troubleshooting purposes.
	TxLost:	0	*	
	<b>BACnetIP [6]</b>			
	<b>For models connected to BACnet IP.</b>			
	RxValid:	0	*	Displays information on the received communication frames for troubleshooting purposes.
RxInvalid:	0	*		
RxLost:	0	*		
Tx:	0	*	Displays information on the transmitted communication frames for troubleshooting purposes.	
TxLost:	0	*		



<b>Network</b>	BACnetIPPort:	47808	min: 0, max: 65535	Set the User Datagram Protocol (UDP) port number. BACnet port number is set by default.
	<b>ModbusServer [1]</b>			<b>For models connected to Modbus.</b>
	Units:	Imperial	Metric, Imperial	Select whether to use a metric or imperial system of units for the Modbus server.
	<b>ModbusRTU1In [4]</b>			<b>Only appears if <i>NtwrkOption</i> is set to <i>Modbus</i>.</b>
	MAC:	1	min: 1, max: 247	Set the Modbus MAC address.
	Autobaud:	Yes	No, Yes	Enable or disable automatic baud rate detection.
	PortConfig:	No Parity, 2 Stop Bits	No Parity, 2 Stop Bits Even Parity, 1 Stop bit Odd Parity, 1 Stop bit	Select the Modbus communication port configuration.
	BaudRate:	19200	9600, 14400, 19200, 38400, 57600	Select the baud rate for data transfer.
	<b>BACnetETH [5]</b>			<b>For models connected to BACnet Ethernet.</b>
	RxValid:	0	*	Displays information on the received communication frames for troubleshooting purposes.
	RxInvalid:	0	*	
	RxLost:	0	*	
	Tx:	0	*	Displays information on the transmitted communication frames for troubleshooting purposes.
	TxLost:	0	*	
	<b>ModbusTCPiP0In [2]</b>			<b>For models connected to Modbus TCP/IP.</b>
	KeepAliveTimeOut:	5min	min: 1min, max: 1440min	Set the amount of time the communication stays open before connection is cut out, when no signal is received from the device.
	ListeningPort:	502	min: 0, max: 65535	Set the communication port number. Modbus TCP port number is set by default.
	<b>SMTP [7]</b>			
	SSL:	Off	Off, On	If turned to <i>On</i> , a secure socket layer will be used to encrypt the communication between the device and the email server (Port value must be set to <i>587</i> and <i>Username</i> and <i>Password</i> settings must be filled out). If turned to <i>Off</i> , the default socket will be used (use Port <i>25</i> to use server without login account or Port <i>587</i> if login details for email account have been entered).
	Port:	25	25, 587	If set to <i>25</i> , server to server email transfer is enabled (can only be used if SSL is set to <i>Off</i> ). If set to <i>587</i> , client to server email transfer is enabled.
	ServerAddr:	192.168.100.100		Configure the server IP address for the email account.
	From:	<i>Current value</i>		Set the email address that will be sending the humidifier notification messages.
	To:	<i>Current value</i>		Set the email address that will be receiving the humidifier notification messages.
Username:	<i>Current value</i>		Set the login username for the email account.	
Password:	<i>Current value</i>		Set the login password for the email account.	
<b>Notify [3]</b>				



<b>Network</b>	Alarm:	Off	Off, On	If turned to <i>On</i> , then the humidifier alarm messages will be sent to the email configured in the <i>SMTP</i> sub-menu.
	Warning:	Off	Off, On	If turned to <i>On</i> , then the humidifier warning messages will be sent to the email configured in the <i>SMTP</i> sub-menu.
	AppMsg:	Off	Off, On	If turned to <i>On</i> , then the humidifier event messages will be sent to the email configured in the <i>SMTP</i> sub-menu.
<b>Communication</b>	<b>IPSettings[10]</b>			
	DHCP:	Inactive	Inactive, Active	Select whether to enable Dynamic Host Configuration Protocol (DHCP) to automatically provide an IP address.
	RstIPSetting:	No	No, Yes	Select whether to restart the IP module, in order to allow recent parameter modifications to be effective.
	StaticAddress:	192.168.1.100		Configure the static IP address.
	StaticSubnetMask:	255.255.255.0		Configure the static subnet mask.
	StaticDefaultGateway:	192.168.0.100		Configure the static default gateway.
	StaticDnsServer:	192.168.10.50		Configure the static DNS server.
	ActualAddress:	<i>Current value</i>	*	Displays the actual IP address.
	ActualSubnetMask:	<i>Current value</i>	*	Displays the actual subnet mask.
	ActualDefaultGateway:	<i>Current value</i>	*	Displays the actual default gateway.
	ActualDnsServer:	<i>Current value</i>	*	Displays the actual DNS server.
	<b>ETHSettings[1]</b>			
	EthernetMacAdd:	<i>Current value</i>	*	Displays the MAC address of the Ethernet interface. <b>(Only applicable if using an Ethernet connection.)</b>

## List of Alarms and Warnings

Table 13 - List of Alarms

Display	Description	Alarm Reset
<b>For each Zones</b>		
AirFlow (Zone A to D)	Indicates that the airflow sensor (of Zone A to D) is open. Verify that the signal from the airflow sensor is present at the controller's input on the PCB and verify wiring.	Automatic
SupplyHighLimit (Zone A to D)	Indicates that the high limit item (of Zone A to D) is open. Verify that the signal from the supply high limit sensor is present at the controller's input on the PCB and verify wiring.	Automatic
Interlock (Zone A to D)	Indicates that the interlock and the cut-out circuitry (of Zone A to D) are open. Verify that the signal from the interlock sensor is present at the controller's input on the PCB and verify wiring.	Automatic
<b>Pump Unit Alarms</b>		
HighLimitCutout	Indicates that the high limit cutout has been activated due to a reading that exceeds the high limit setpoint. Ensure that the high limit humidistat is operating correctly and is not located too close in proximity to the distribution apparatus.	Automatic
RelayFuse	Indicates that there is an issue with the printed circuit board fuse. Check the status of the fuse and replace it if defective.	Automatic
Airflow	Indicates that the airflow sensor is open. This fault does not trigger the alarm contact (no message will be displayed) but will prevent the SKH4 from running. Verify that the signal from the airflow sensor is present at the controller's input on the PCB and verify wiring.	Automatic
SupplyHighLimit	Indicates that the high limit item is open. Verify that the signal from the supply high limit sensor is present at the controller's input on the PCB and verify wiring.	Automatic
Interlock	Indicates that the interlock and the cut-out circuitry are open. This fault does not trigger the alarm contact (no message will be displayed) but will prevent the SKVF from running. Verify that the signal from the interlock sensor is present at the controller's input on the PCB and verify wiring.	Automatic
MemoryCard <i>(Warning)</i>	Indicates that the SD card has been detected, but it is not operating correctly or is non-functional. Verify the SD card and replace if defective.	Automatic
USB Device <i>(Warning)</i>	Indicates that the USB device has been detected, but it could not be read or is not operating correctly. Verify the functionality of the USB device and replace if defective.	Automatic
WatHiTemp	Indicates that the water temperature is above the MaxWatTemp, which causes the humidifier to exit the spray state and perform a drain in order to lower the temperature and resume operation. If the temperature is still too high, an alarm will trigger and demand a manual reset.	Manual *
WatLoTemp	Indicates that the water temperature is below the MinWatTemp, causes the humidifier to exit spray state.	Manual *
OutHiPress	Indicates that the water pressure has raised above the MaxHighPress, causes the humidifier to exit spray state.	Manual *
OutLoPress	Indicates that the water pressure has fallen below the MinHighPress, causes the humidifier to exit spray state.	Manual *
InLowPress	Indicates that the low-pressure switch is open for the time greater than WaterInletPressDelay during the operation of the humidifier.	Automatic
WaterLeak	Indicates that a water leak has been detected. Verify the water line for signs of leaks and ensure that all piping and water connections have been properly installed and secured.	Manual *
Config	Indicates that the configuration is not valid in factory settings. For example, at least one stage is not enabled, or a drain stage is not enabled.	Automatic
NtwkCtrlState	Indicates that the communication attempt to the BMS server has exceeded the delay defined by the <i>NtwkTimeout</i> setting. Verify the wiring between the humidifier and the BACnet or Modbus network and ensure proper connection. (Only applicable for units connected to BACnet or Modbus).	Manual *
ServiceDue	Indicates that the due date for servicing the SKH4 unit has arrived. See Servicing and Maintenance section on page 57 for details.	Manual ***

\* Use the ResetAlarms function in the Request setting (see page 36).

\*\* Use the ResetServCnt function in the Request setting (see page 36).

## Distribution Installation

Refer to Neptronic's guideline in Space Mist Humidification Design for additional information and recommendations on the design of a hydraulic distribution network. Consult the respective design guides for each of the three distribution techniques.

### Spraying in Space (Standard)

An in-space hydraulic network is made up of piping that starts at the stage valve and goes towards the drain valve. Along this run of pipe, single nozzles, or fan-assisted distributors (optional), can be placed in order to spray directly into the area.

- Plan a location that is easy to access and permits easy inspection and servicing of the nozzles.
- The hose used must be stainless steel tubing or flexible nylon hose. It must be appropriately sized for the flow and the in-line pressure.
- Hoses must be maintained/attached securely and must not move when pressure is applied.
- Do not install the ramp and nozzle where failure of the system could cause damage to the building structure or to other expensive equipment.
- Ensure that the mist is not directed and or at risk of condensing on any equipment.

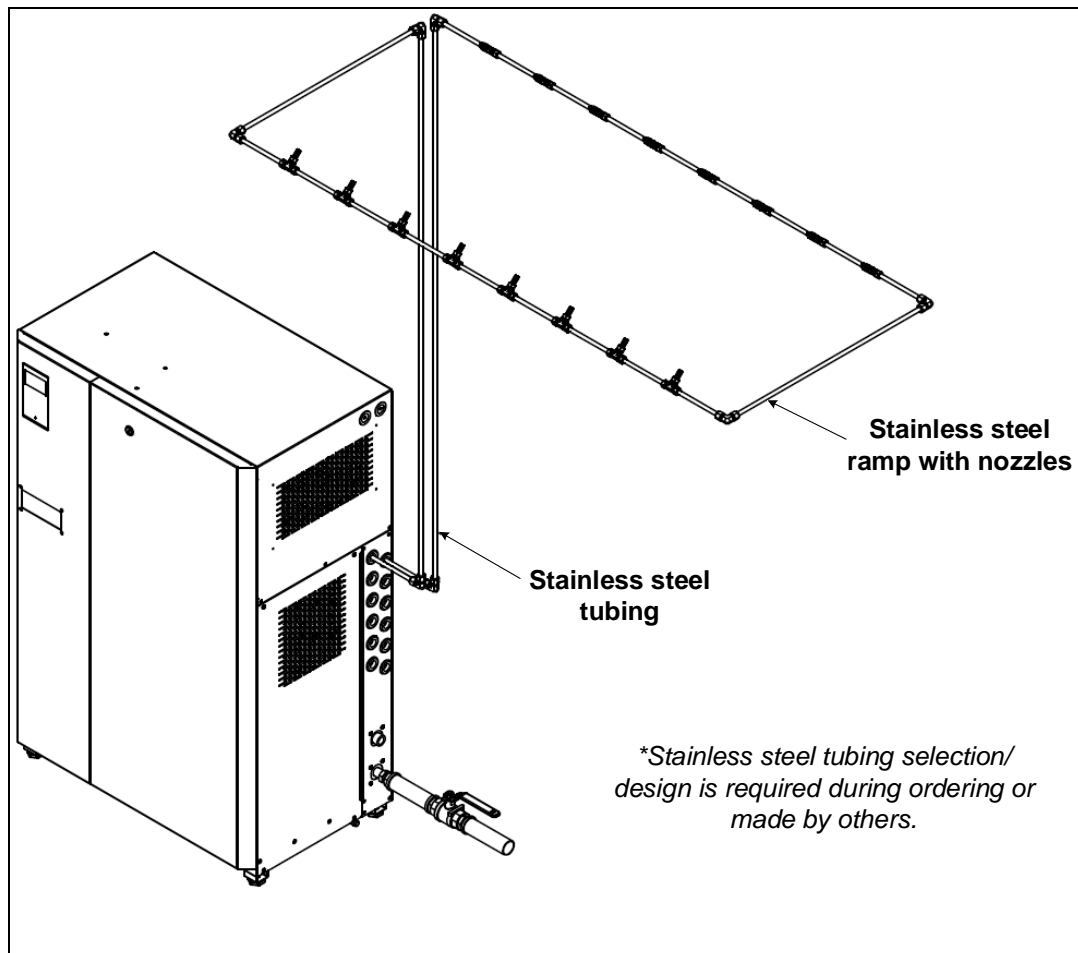

Illustration 18 - Typical Installation with Rigid Nozzle Ramp

High-pressure water outlets use a DN10 or DN15 flexible high-pressure nylon hose (available upon request) connected to a push-to-connect fittings (available upon request) with the respective stage and drain valves.

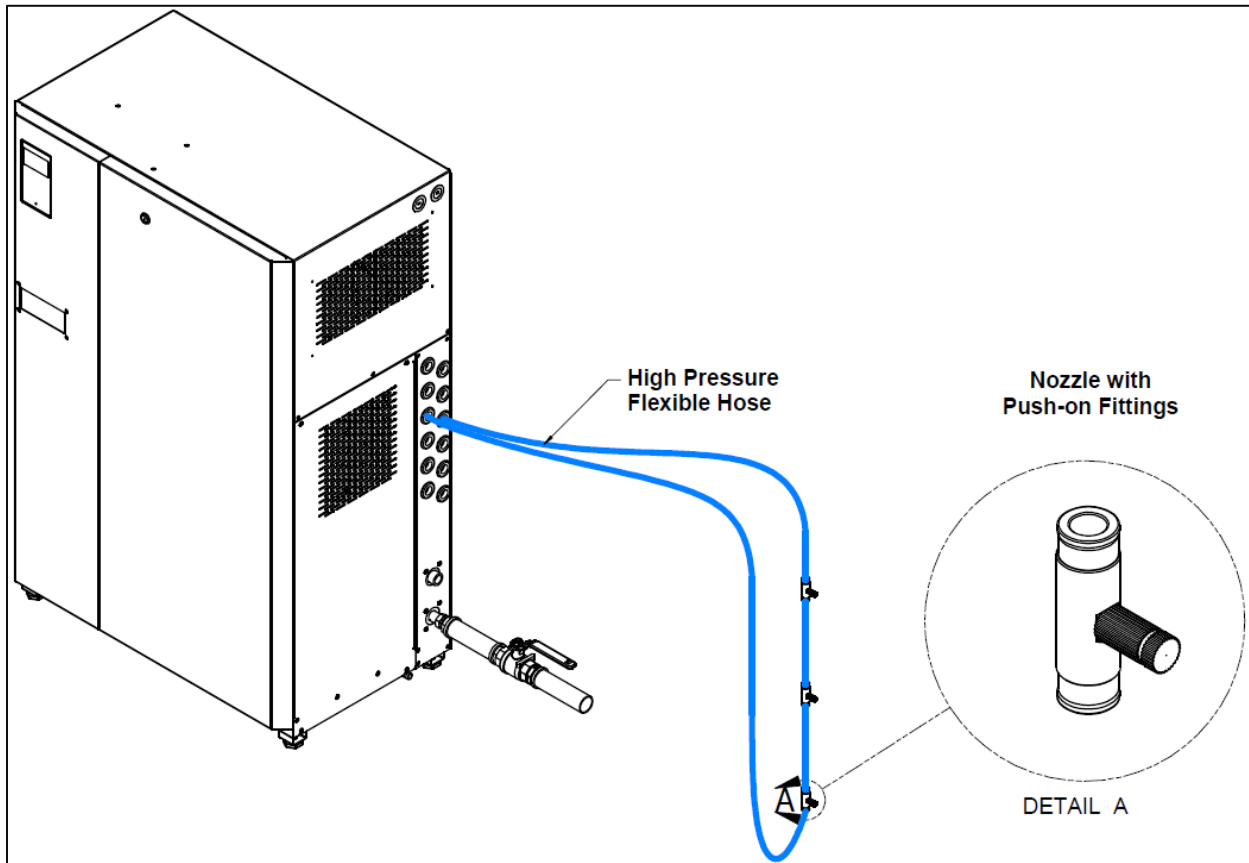

Illustration 19 - Typical Installation with Flexible Nylon Hose

## Spraying in Space with Fan-Assisted Distributors

- Plan a location that is easy to access and permits an easy inspection and servicing.
- Do not install the distributors where failure of the system could cause damage to the building structure or to other expensive equipment.
- Ensure that the mist is not directed and condensed on any equipment, especially the electrical equipment.
- Respect clearances for absorption specified in the fan assisted design guide.

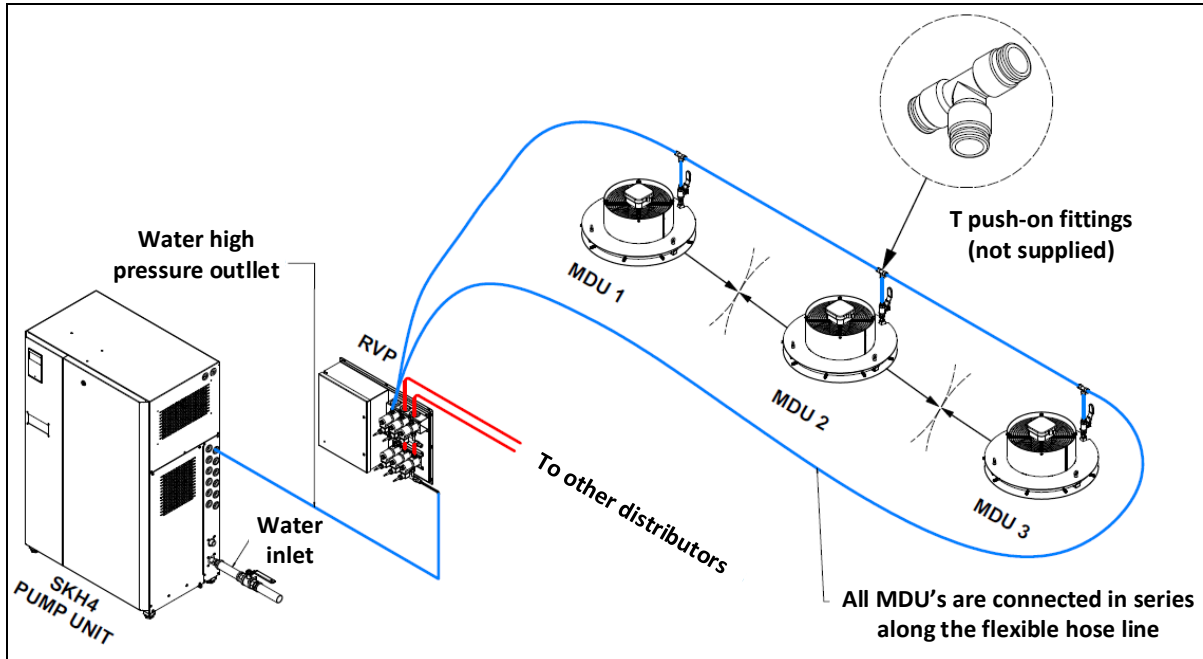

Illustration 20 - Fan-Assisted Distributors Typical Installation



## Ceiling Installation

To install the MDU to the ceiling, connect two metallic suspension cables (not supplied) to the three rings. Verify the strength of the cables and ensure that they can support the weight of the distributor (see table) before commencing installation.

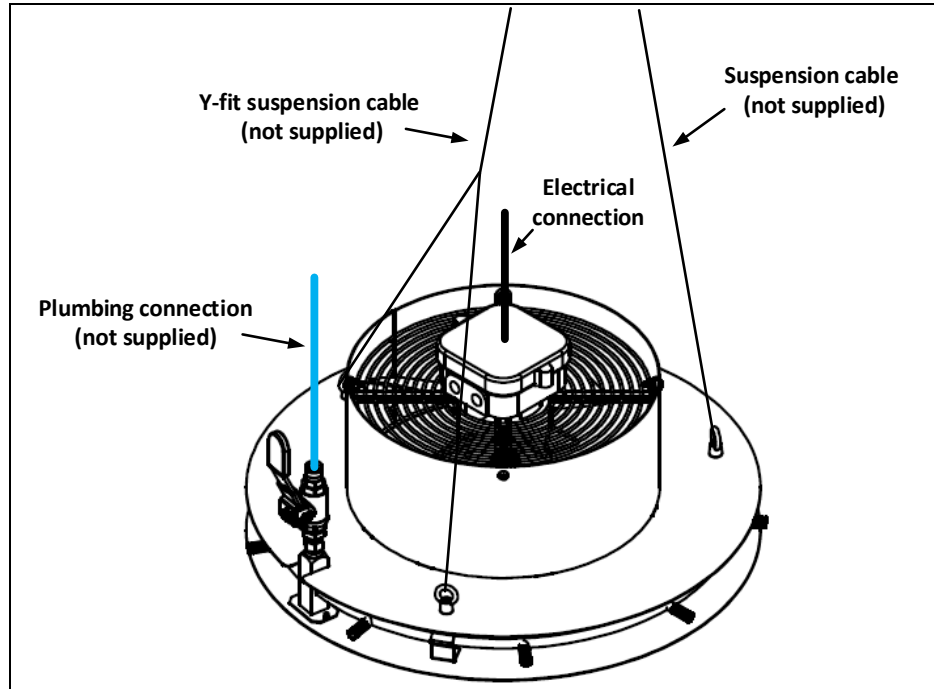

Illustration 21 - ADU Ceiling Installation

## Wall Installation

To install the distributor to the wall, fasten with screws (not supplied) to a suitable location:

- Check the solidity of the chosen support or wall (brick, concrete, or stud partition wall) on which the distributor remote panel will be mounted.
- Drill holes matching the hole of the support into the support or wall (anchors not supplied):
- Ensure that the hole dimensions (diameter and depth) adhere to the recommendations of the chosen anchors. If required, you can install and then bolt the anchors.
- Affix screws (not supplied) with a minimum diameter of 6mm to all fixation points.
- Adjust the positioning of the distributors and lock in place using the fixation hardware on the distributors.

## Spraying in Duct

- Plan a location that is easy to access and permits an easy inspection and servicing of the nozzle.
- Do not install the ramp and nozzle where failure of the system could cause damage to the building structure or to other expensive equipment.
- Ensure that the mist is not directed and condensed on any electrical equipment.
- Construct the drainpipe in such a way that there is no water accumulation and stagnation.
- The wet section of the duct must be constructed in stainless steel in order to prevent corrosion and must be equipped with a pan drain outlet in order to remove any water residue. See guide for more details.

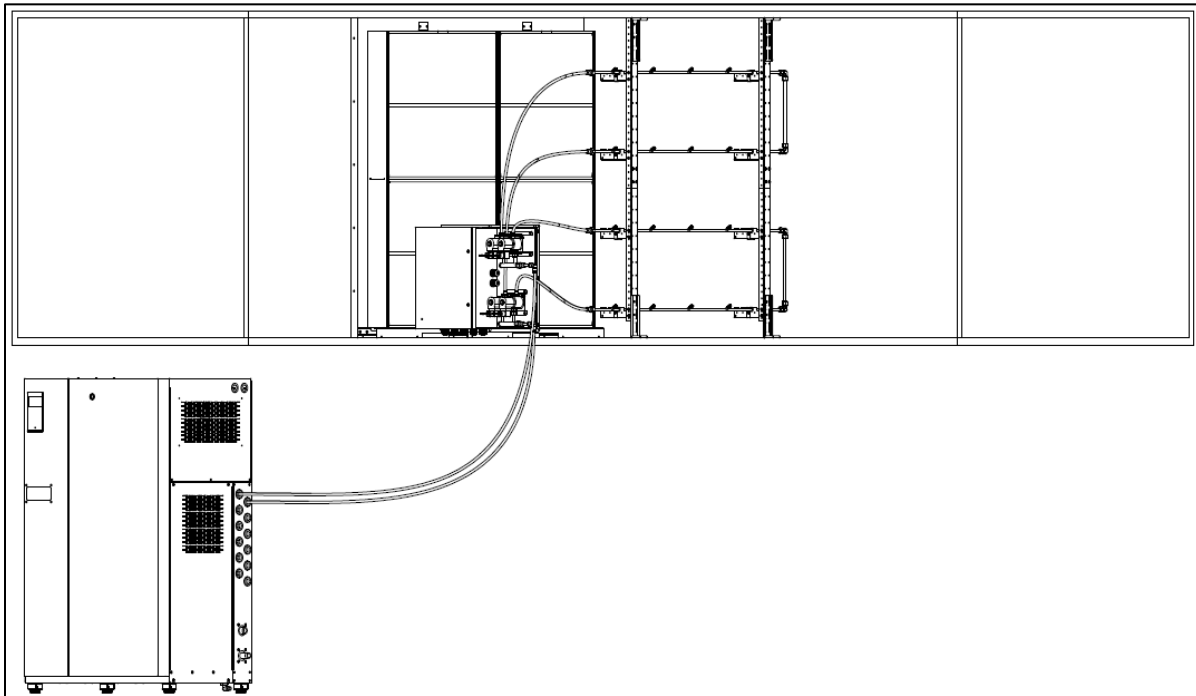

Illustration 22 - In Duct Distribution

Refer to the **SKH4 In Duct Mist Distribution Guide** for assembly instructions.

## Optional – Remote Valve Panel (RVP)



**WARNING: Risk of electric shock. Disconnect the appliance from the electric supply before commencing installation.**

An optional remote panel serves two purposes. The first is to allow a connection for the fan-assisted distributors and a connection to the control wire to start the fan before the spraying action. The second is to allow for valves to be placed outside of the enclosure, to minimize the length of piping during installation. Control signal wires are connected from the pump unit's PCB to the relays in this electrical panel in order to remotely activate the solenoid valves.

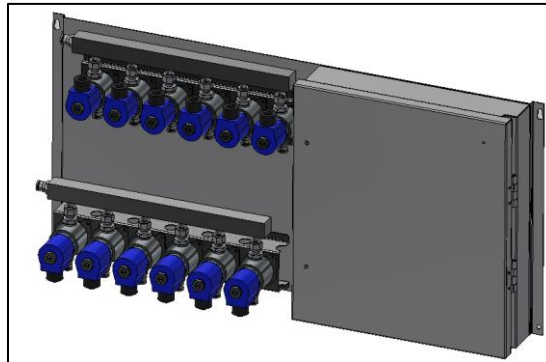

Illustration 23 - Remote Valve Panel

## RVP Dimensions

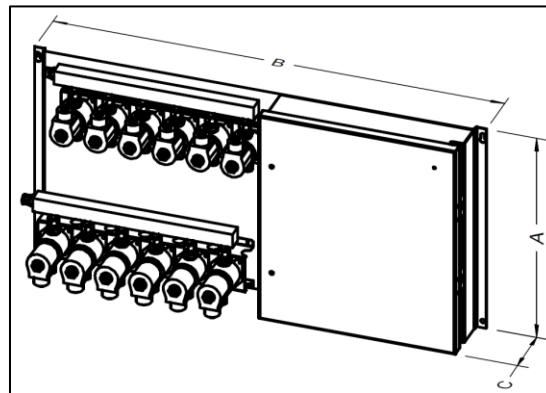

Illustration 24 - RVP Dimensions

Table 14 – Remote Valve Panel (RVP) Dimensions & Weight

Model	Dimensions (mm)			Weight (kg)
	A	B	C	
RVP 0	381	381	101	9
RVP 2		508		16
RVP 4		635		23
RVP 6		762		29

## Location

- Plan a location that is easy to access and permits an easy inspection and servicing of the RVP panel.
- Do not install the RVP panel where failure of the valve could cause damage to the building structure or to other expensive equipment.
- Ensure that the location is ventilated appropriately and that the ambient temperature is less than 30°C.

## Positioning

- There is no minimum clearance required for safety purposes.
- Provide a minimum clearance of 0.80 m in front of the RVP panel, in order to allow access to the connections and servicing.
- It is recommended (but not mandatory) to allow some clearances on both sides and on the top of the RVP panel for ease of service.

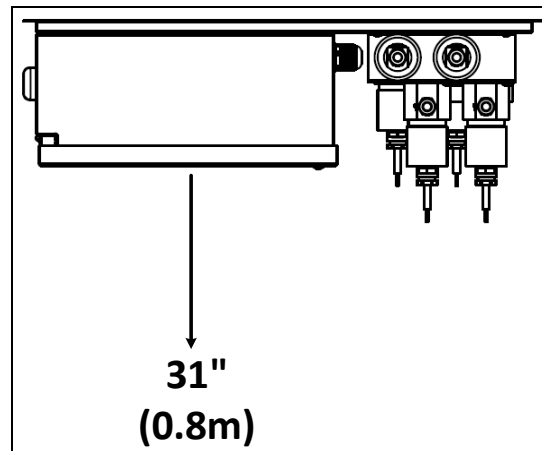

Illustration 25 - RVP Clearance

## Wall Mounting

- Use the keyholes located on the back of the RVP panel.
- Check the solidity of the chosen support or wall (brick, concrete, or stud partition wall) on which RVP panel is mounted.
- Drill holes for the upper anchors (holes with keyholes) into the support or wall, as per dimensions specified in the below table (anchors not supplied):
- Ensure that the hole dimensions (diameter and depth) adhere to the recommendations of the chosen anchors. If required, you can install and then bolt the anchors.
- Affix two screws (not supplied) with a minimum diameter of 6mm to the top keyholes. Leave a clearance between the head screws and the wall to permit the mounting of the RVP panel.
- Hang the RVP panel on the two screws. Based on the size and weight of the RVP panel, you may need the assistance of another person.
- Tighten the screws to secure the RVP panel once it is positioned on the upper screws.
- Install and secure two screws (not supplied) onto the bottom screw holes of the RVP panel.

## RVP Current Calculations

In order to properly calculate the current draw of the RVP, take the following into consideration:

- The type of fan used in the application.
- The number of fans used in the application.
- The number of valves used in the application.

Fan RLA (A) *	RVP Type	Amperage (VA)
0.5 or 0.9	RVP 0	0
	RVP 1 & RVP 2	200VA
	RVP 3 & Above	350VA

\* Refer to the Capacities and Power of the Fan-Assisted Distributors on page 13 for more information on the fan amperage.

If unsure, please consult with the factory for the design and sizing of the equipment. Always refer to the rating on the plate of the electrical panel to properly size the conductors.

# Start-Up Procedure

---

Once the installation is complete, follow this start-up procedure in order to ensure that the SKH4 High-Pressure Atomizer is ready for normal operation. We strictly recommend following this procedure in order to avoid any anomaly resulting from inaccurate installation of the components.



**Initial verification and start-up must be carried out by suitably qualified personnel.**

## Initial Verification

- |  |   |
|--|---|
| <b>Clearance</b>                       | 1. Ensure that the humidifier cabinet is installed in a location where it can be serviced correctly. <input type="checkbox"/>   |
|  | 2. Ensure that the pump station is installed in a temperature-controlled environment of less than 86°F (30°C). Verify that the pump station is fixed securely to the ground and that it remains stable. <input type="checkbox"/>  |
| <b>Mechanical</b>                      | 3. If an in-duct spray system is used, ensure that the nozzle rack assembly is correctly installed within the AHU. <input type="checkbox"/>   |
|  | 4. If an MDU or ADU is used for in-space spray distribution, ensure that it is correctly installed and secured onto the ceiling. <input type="checkbox"/>   |
|  | 5. Verify that the pump station water connections are installed properly: <input type="checkbox"/>  |
|  | a) Ensure that water is supplied to the humidifier and that an isolation valve is installed on the water line. With the water isolation valve turned on, verify that there are no apparent leaks. <input type="checkbox"/>  |
|  | b) Ensure that the pan drain outlet is properly connected to a flexible hose and that it is directed towards an open drain. Verify that the water drainage is not obstructed. <input type="checkbox"/>  |
| <b>Hydraulic</b>                       | 6. Verify that the zone hydraulic connections are installed properly: <input type="checkbox"/>  |
|  | a) If an in-duct spray system is used, ensure that all nozzle ramps are properly connected and assembled onto the rack assembly. <input type="checkbox"/>   |
|  | b) If a standard in-space spray distribution system is used, ensure that all nozzles within the ramp have been connected in series and that they are properly secured. <input type="checkbox"/>   |
|  | c) If an in-space fan-assisted spray distribution system is used, ensure that all units are connected in series and that they are properly secured. <input type="checkbox"/>  |
|  | d) Ensure that isolation valves are opened on all the fan-assisted distributors <input type="checkbox"/>  |
|  | 7. Check that pre-treatment filters and equipment are connected to the water inlet and operational. <input type="checkbox"/>  |
|  | 8. Verify that the power supply (voltage) conforms to the appliance name plate on the side of the humidifier. <input type="checkbox"/>  |
| <b>Electrical</b><br><b>Electrical</b> | 9. Ensure that the Interlock is properly connected to the controller. If Interlock is not used, verify that a jumper is connected between terminals TB3 1&4. <input type="checkbox"/>   |
|  | 10. If a room or duct humidistat is used, verify that it is fixed securely to the wall or duct and to the pump unit, respectively, and ensure that it is properly connected to the controller. Verify that the setpoints and the address are properly adjusted. <input type="checkbox"/>                |
|  | 11. If a TRUB is used, verify that it is fixed securely to a support or wall located within the desired zone and ensure that it is properly connected to the pump unit. Verify that the setpoints are properly adjusted. Refer to the TRUB documentation for more information. <input type="checkbox"/> |

## Start-Up

---

1. Proceed to start-up the humidifier, as follows:
  - a) Remove the Front door and Right door (located on the right side of the front of the humidifier cabinet), in order to gain access to the high-pressure pump.
  - b) Ensure the zones and the number of stages are configured, and the stage valves are connected to the hoses properly.
  - c) In the menu *Installation/quickConfig/Stage[ ]*, each stage needs to be defined. Input which zone (control signal) each stage is connected to and input the capacity (L/h) for the stage control. Input the drain valve associated with the stage valve (the two valves should form a loop with the nozzles in between). The drain volume can be increased if the line is very long, in order to ensure depressurization of the line.
  - d) **Important!** If the pump unit is stainless steel, loosen the top hex socket screw of the pump in order to bleed the air (see yellow label). This needs to be performed during the drain until the output is clear of any air bubbles, while the pump is running at a low speed. This will spill a bit of water as the air is pumped out in the output and through the valve.
  - e) Press the Menu button ✓ to access the Main Menu screen and enter the password 4433 (Installation level). Navigate to the **Service** menu. Then, select the **Diagnostic** mode and set **DiagPeriod** to 3 minutes and set **DiagCmd** to **Drain** and set **DiagState** to **On**, to start the drain sequence. The system will then start draining.  
**Warning!** This mode disables alarms to give the user full control. To turn off diagnostic mode, exit the menu, or off button, to change **DiagState** to **off**.

### Start-up

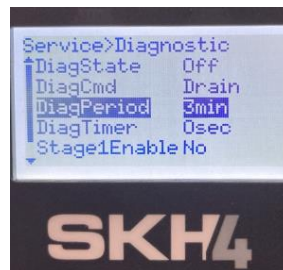

- f) **Important!** If the pump unit is Stainless Steel, once it's free of air, retighten the top hex socket screw of the pump while it's running to seal off the bleeding port. The drain sequence automatically stops after 3 minutes, it can be restarted again if the pump has not been bled.
- g) If the drain is successful and no leaks are detected, the system can be tested at a high pressure.
- h) Change the **DiagCmd** to **Spray** and enable each stage, individually at first since the connections and distributions nozzles need to be inspected for leaking and spraying
- i) Set **DiagPeriod** to 10 minutes and set **DiagState** to **On** to start the high pressure spray sequence.

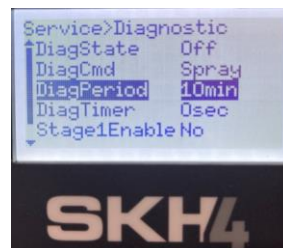

- j) Check the pressure reading on the controls. Pressure should be stable after the air was evacuated from the line.

**Warning!** This could result in nozzle spitting big water droplets at first.

- k) If the pressure reads <1000psi, slowly turn the **high pressure unloader** on the pump **clockwise** until a value of **1000psi** is displayed in the **Pressure** on the Home screen and also on the high pressure manometer located on the front of the unit. The spray sequence of the diagnostic mode will stop automatically after 10 minutes.

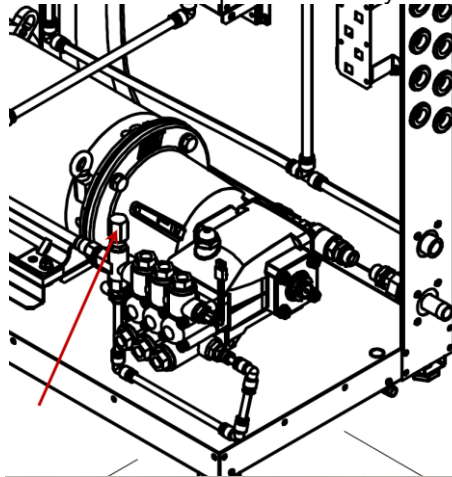

### Start-up



- l) Verify that all nozzles within the activated stage are spraying correctly and that the pressure is stable at 1000psi.

**Warning!** With the low and high pressure flush, depending on the installation piping, there can be a lot of particles that will be cleaned of the system and can clog nozzles and valves. Verify that all the nozzles close properly.

- m) Do steps d) through j) with all the remaining stages (except bleeding, that steps only needs to be done once).

- n) Exit diagnostic mode. Turn on the humidifier by pressing and holding the Power button  for 3 seconds. Verify that the power display LED light is turned on. If there's a demand for a zone, the unit will start.

- o) Check the Home screen that the **Pressure** is at **1000 psi**, **ControlState** is **Normal**, **State** is **Spraying** If there is any **Alarm** appears, verify the list of Alarms and possible causes provided in the manual.

### Safety test

2. Check the location of the Airflow switch in the system and its operation by stopping the fan. With no air movement in the AHU, the humidifier should automatically stop.

3. Reset the Airflow switch if needed.

### End

4. The humidifier is now ready for normal operation.



## Diagnostic mode

If required, a diagnostic mode is accessible through the Service menu, the diagnostic mode allows manual activation and override of the SKH4. It's possible to activate each stage without any demand to the pump. This allows for inspection, purging the air out of the line and validation of operation of a particular stage.



**Alarms and interlocks coming from zone(s) are bypassed while manual override is active.**

Enter the mode from the Service, Diagnostic mode. The function allows to select the action to drain or to pressurize the stage(s) selected below, and then to turn the action on or off.

First, select the command type (Spray or Drain), set desired time for test, and enable or disable the desired stage(s) manually. To turn on the action, change the DiagState to ON.

Going out of the menu, changing Command type or the end of Period will turn the State back to Off. The exiting of the diagnostic state sends the SKH4 to its regular Off state.

## Servicing and Maintenance



This humidifier must be installed, operated, and maintained by suitably qualified personnel and in accordance with this manual.



Before performing any servicing on the unit, turn off the disconnect and use Lock Out procedure.

Damage to the other parts of the SKH4 system are most often caused by particles or debris in the water. Ensure constant quality of water supplied to the unit. Inspection of parts of the pump unit and of the network of distribution is necessary to ensure the proper function of the system and to prevent leakage.

## Preventative Maintenance

Component	How Often is Maintenance Required	Maintenance Steps
Pressure manometers	Every 2000 hours	<ul style="list-style-type: none"> <li>- Inspect the high pressure and low pressure manometers in front of the unit and verify that the pressures match the ones indicated under the <i>pressure</i> settings in the menu Menu - General [Level 1 - No password required] page 31.</li> <li>- If the pressure is not the same, replace the high pressure or low pressure manometer.</li> </ul>
Hydraulic pipes		<ul style="list-style-type: none"> <li>- With the unit turned on, check for leaks coming from the water supply inlet, high-pressure outlet and zone distribution piping.</li> <li>- If a leak is found, replace the leaking pipes or fittings.</li> </ul>
Nozzles		<ul style="list-style-type: none"> <li>- With the unit turned on, verify if the nozzles are blocked during normal operation.</li> <li>- If the nozzles are blocked, disassemble them for inspection:               <ol style="list-style-type: none"> <li>a) If blocked by large particles, remove the particles and reassemble the nozzles.</li> <li>b) If blocked by the presence of mineral deposit or scale, replace the nozzles.</li> </ol> </li> </ul>
Distributor fan (option)		<ul style="list-style-type: none"> <li>- With the unit turned on, verify whether the fan is operating correctly and without any problems.</li> <li>- Replace the motor fan if faulty operation is observed.</li> </ul>
Droplet separator – Duct Distributor (option)	Every 2500 hours (up to 5000 hours depending on condition)	<ul style="list-style-type: none"> <li>- Verify that the droplet separator is not being obstructed by scale.</li> <li>- If there is scale, proceed to de-scale the droplet separator as per the steps described in the De-scaling the Droplet Separator section.</li> </ul>

## Preventive Maintenance (continued)

Component	How Often Maintenance is Required	Maintenance Steps
Stainless Steel pump (SKH4-XXXXS models)	Every week	<p><u>Visual inspection</u> for the absence of water leaks. Verify that nominal pressure is normal for your system. Loss of pressure can be an indication that the distribution network needs servicing or the pump. Pump noise that degrades is also an indicator that maintenance is required.</p>
	Every 8000 hours	<p>Removal of the pump to inspect the parts and <b>replacing the O-ring is necessary</b> to ensure the life of the pump. A replacement seal kit is available from the Neptronic factory. Contact customer service for the kit and detailed instructions.</p> <p><u>Disassembling and inspecting the pump:</u></p> <ul style="list-style-type: none"> <li>- Cut off the water supply and disconnect the hoses from the inlet and outlet of the pump.</li> <li>- Unscrew the fasteners of the bell housing from the motor and remove the pump from the bell housing.</li> <li>- Perform the disassembly of the pump on a clean work bench in order to prevent any contamination with particles or chemicals.</li> <li>- Follow the guide available from Neptronic.</li> <li>- Inspect all parts for wear or scratches</li> </ul> <p><u>Reassembly</u></p> <ul style="list-style-type: none"> <li>- Lubricate all threads with a PTFE type lubricant.</li> <li>- At reassembly, lubricate all parts with clean filtered water.</li> <li>- Follow the guide for the reassembly and replacement of the seals with the parts from the kit.</li> <li>- Fastened to the bell housing, add the coupling, and place it back onto the motor, ensuring that the couplings mesh together.</li> </ul> <p><u>Restarting the unit:</u></p> <ul style="list-style-type: none"> <li>- Follow the steps outlined in the start-up section to restart the humidifier and ensure that it is operating correctly before resuming normal operation.</li> </ul>
Brass pump (SKH4-XXXXB models)	Every week	<p><u>Visual inspection</u> of the oil level through the sight glass, ensuring absence of water mixed in the oil and absence of any oil leaks. Ensure that nominal pressure is normal for your system. Loss of pressure can be an indication that the distribution network needs servicing or the pump. Pump noise that degrades is also an indicator that maintenance is required.</p>
	Every 500 hours	<p><u>Oil change (~10min)</u></p> <ul style="list-style-type: none"> <li>- Unscrew both caps with a pan underneath the pump in order to catch the oil. Inspect the oil for debris or particles in it; if found, it can be an indicator of damage to the pump.</li> <li>- Screw back the bottom cap and fill the oil reservoir to at least the middle of the red dot.</li> <li>- Screw back the top cap.</li> <li>- Dispose of the oil properly according to the local regulations.</li> </ul>
	Every 2500 hours (up to 8000 hours depending on condition)	<p><u>Seal replacement (~60min)</u></p> <ul style="list-style-type: none"> <li>- Refer to the detailed guide provided with the seal replacement kit from Neptronic.</li> </ul>
	Every 5000 hours (up to 16000 hours depending on condition)	<p><u>Valve replacement (~60min)</u></p> <ul style="list-style-type: none"> <li>- Refer to the detailed guide provided with the seal replacement kit from Neptronic</li> </ul>

## Nozzle Cleaning

The SKH4 nozzles will eventually get clogged by the accumulation of scale and/or particles inside the tubing, resulting in a blocked or leaking nozzle which will require cleaning or replacement of certain parts.

- A blockage of the nozzle will require cleaning the nose (#1) and piston (#3).
- A leakage will require the cleaning of the plastic ball (#4) and the seat inside of the body (#5).
- Parts (#7,8 and 9) are optional PE filters and must be replaced whenever clogged.
- The nozzles can be cleaned using light descaling agents such as acetic acid (vinegar) and a plastic brush.











	1		Nozzle nose
	2		O-Ring
	3		Plunger
	4		Spring-load Viton ball
	5		Nozzle body
	6		O-Ring
	7		PE filter
	8		Filter body
	9		O-Ring

Illustration 26 - Nozzle Parts List

## De-scaling the Droplet Separator

### Step 1 - Preparation

- Refer to the manufacturer's recommendations for concentrations to apply and the method of preparation of the solution. When using white vinegar (acetic acid), do not exceed a concentration of 250-260 ppm when descaling the media.
- Ensure that the air system (central air or ventilation system) is stopped.
- Ensure that the SKH4 is stopped.



**CAUTION: When working with de-scaling solutions, always wear appropriate personal protective clothing, protective gloves, and eye protection.**

### Step 2 - Dismantle the Droplet Separator

- Turn off and isolate electrical supplies to the unit.
- Remove all media cassettes.

### Step 3 - Prepare the De-scaling Solution



**CAUTION: Risk of emanation of gas irritants, ensure to perform these tasks in a well-ventilated area. It is recommended to perform the following steps outside.**

- Mix the de-scaling solution according to the manufacturer's recommendations.
- Use a clean container of a suitable size to completely immerse each media cassette.
- Ensure that a second clean container of a suitable size is within reach and has been filled with clean, clear water to immerse each cassette after de-scaling.

### Step 4 - Remove Scale from Individual Cassettes

- Using a soft brush, lightly brush any loose scale from the surface of the media.
- Lower the individual cassettes into the de-scaling solution.
- Keep each matrix cassette in the solution until the reaction between the calcium on the matrix and the de-scaling solution is complete.



*Note: The effect of the de-scaling solution will vary depending on the condition of the media's material. For an improved effect, the above process may have to be repeated.*

- Clean and if necessary, apply the de-scaling solution on all parts which are covered with scale.

### Step 5 - Rinse

- Lift the individual cassettes out of the acid solution, while allowing any excess de-scaling solution to drip, and directly submerge them into the clean water container.
- If necessary, rinse a second time while profusely wetting the media.

### Step 6 - Re-assemble and Restart

- Replace the media cassettes and media frames on the droplet separator.
- Reconnect the power supply.



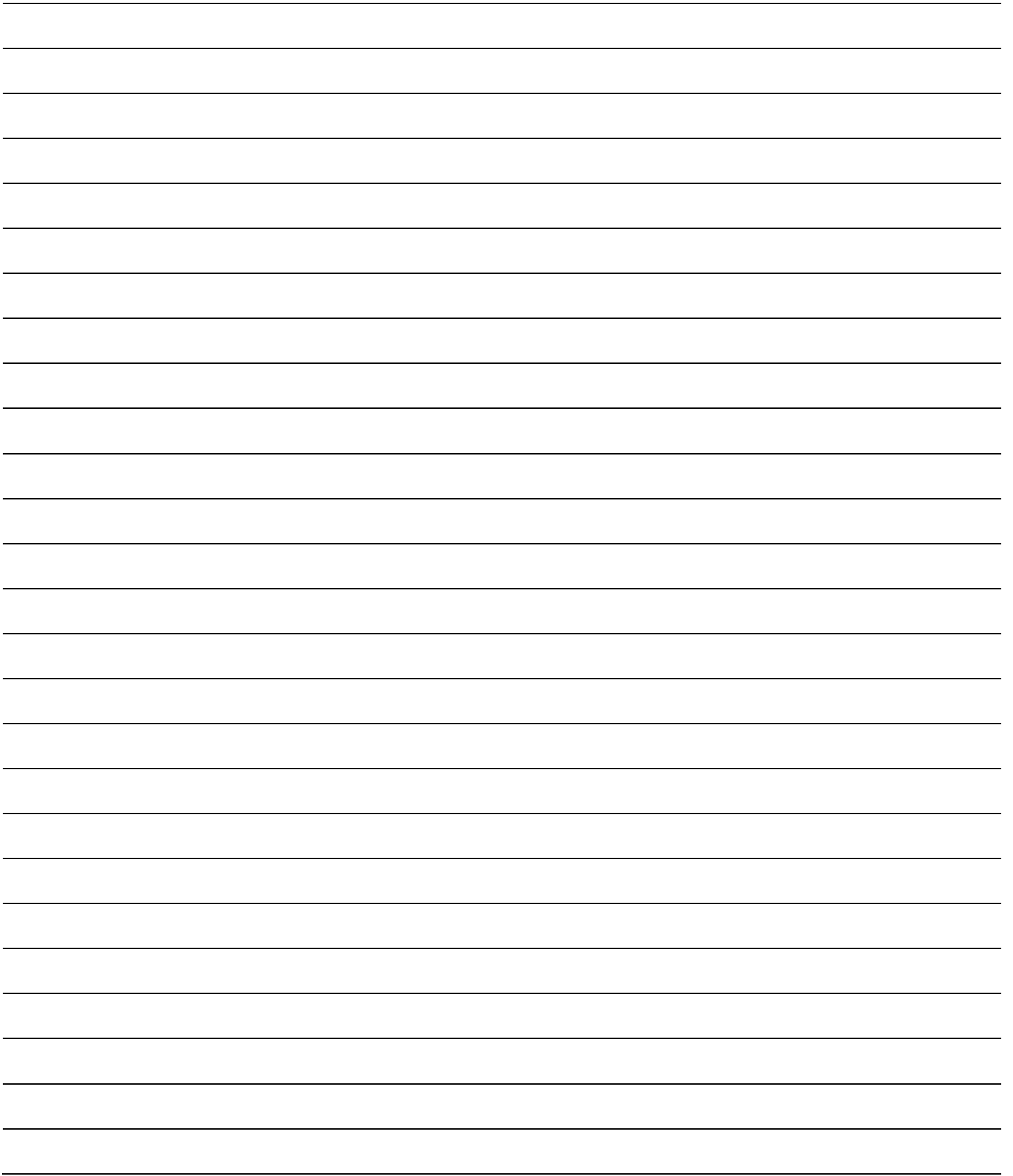



**neptronic<sup>®</sup>**

400 Lebeau blvd, Montreal, Qc, H4N 1R6, Canada

**[www.neptronic.com](http://www.neptronic.com)**

Toll-free in North America: 1-800-361-2308

Tel.: (514) 333-1433

Fax: (514) 333-3163

Customer service fax: (514) 333-1091

Monday to Friday: 8:00am to 5:00pm (Eastern Time)