

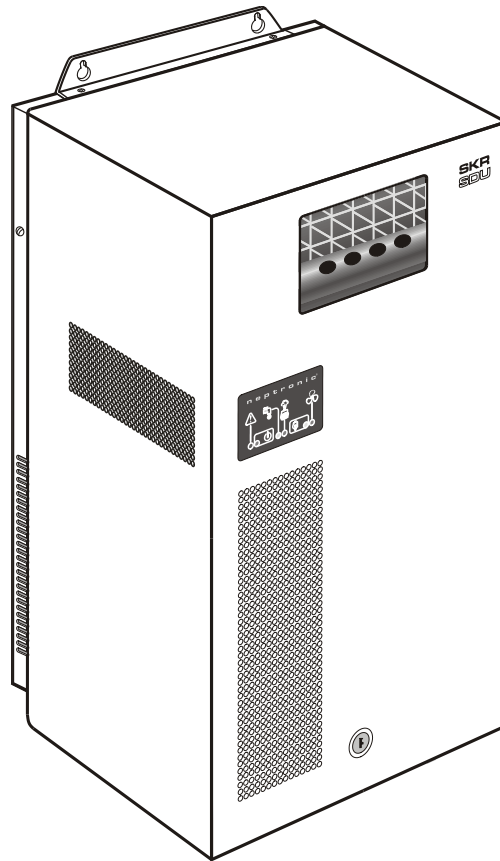

neptronic®

SKR series Steam Humidifier with SDU module

(Patent Pending)



Installation instructions & user manual

READ AND SAVE THESE INSTRUCTIONS



Foreword

Neptronic Company Overview

Founded in 1976, we're a private corporation that designs, manufactures and distributes products for the HVAC industry. Our product line includes intelligent controllers, electronic actuators, actuated valves, humidifiers and electric heaters.

Our products are designed and manufactured by over 250 dedicated employees in our 7,500 m² (80,000 ft²) state-of-the-art facility located in Montreal, Canada. Using a vertical integration model, our entire manufacturing chain is under one roof from software and hardware development, to SMT circuit board assembly, to sheet metal fabrication, to product testing ensuring that our products are engineered to last.

We currently hold several national and international patents and with our continued commitment to research and development, we provide innovative products and technologies for the ever-evolving challenges of the HVAC industry. Exporting over 70% of our sales, we have an exclusive distribution network around the globe that provides comprehensive solutions to our worldwide customers.

About the Manual

These installation and operation instructions have been developed to facilitate the installation of the Steam Humidifier.

- The strict application of these instructions will ensure the conformity of your installation and operation as per the manufacturer's recommendations.
- The application of these instructions is one of the conditions for the application of the warranty.
- The application of these instructions does not ensure, at any time conformity to procedures, regulation or local codes, regarding electric installation and connection to local water supply.

This product has been declared to conform to the applicable Canadian and American safety standards and directives and bear the CSA (c) & (us) mark. The Certificate of Conformity, CSA is available, upon request with the manufacturer.

This product has been declared to conform to applicable European safety and electromagnetic compatibility standards and directives and bear the CE mark. The certificate of conformity CE is available upon request to the manufacturer.

2017[®]: All rights reserved. This document cannot be reproduced totally or partially by any means whether, electronic, mechanical, photocopy, recording or other, without prior written authorization of Neptronic.

Electricity



All work concerned with electrical installation **MUST** only be performed by skilled and qualified technical personnel such as an electrician or a technician with appropriate training). The customer is always responsible for ensuring the suitability of the technical personnel.

Please observe the local regulations concerning the provision of electrical installations.

Correct Use

Neptronic systems and its products are designed only for humidification use. Any other application is not considered appropriate for the intended purpose. The manufacturer cannot be made liable for any damage resulting from incorrect use.

General Warranty

This product is subject to the terms and conditions described at <http://www.neptronic.com/Sales-Conditions.aspx>.

Table of contents

Foreword	i
1. Presentation.....	3
1.1. Description of accessories supplied with the SKR humidifier with a Space Distribution Unit (SDU) module.	3
1.2. SKR with SDU module overview	3
1.3. Numbering system.....	4
2. Definition	4
2.1. Evaporation chamber	4
3. Characteristics	5
4. Mechanical installation.....	6
4.1. General recommendations	6
4.2. Positioning	6
4.3. Wall mounting	6
5. Steam connection	7
5.1. Typical installation	7
6. Plumbing connections.....	8
6.1. Water supply.....	8
6.2. Drain connections.....	9
7. Power supply connections	10
8. Control panel display	11
9. Description of the SKR control PC Boards	12
P.C. Board for SKR-SDU with kit ROO and ROW	12
P.C. Board for SKR-SDU with kit N.....	13
9.3. P.C. Board for modulating SKR-SDU with kit N.....	14
10. Start up procedure	15
11. Description of operation of the SKR.....	15
12. Shut-down procedure.....	16
13. Maintenance.....	16
13.1. General	16
13.2. Evaporation chamber cleaning	16
13.3. Maintenance of the SDU module.....	17
14. Exploded View and Bill of Material.....	18
14.1. Exploded view of the SDU module	18
14.2. Bill of Material of the SDU module.....	18
. Exploded view of SKR.....	19
14.4. Bill of Material of SKR.....	19
15. Types of alarm	20
16. Troubleshooting guide for SDU module.....	21
17. Electrical diagram.....	22
17.1. Electrical diagram for SKR with SDU module – Kit R.....	22
17.2. Electrical diagram for SKR with SDU module – Kit N.....	23
17.3. Electrical diagram for SKR with SDU module – Kit M-N.....	24
17.4. Modulating humidifier with HRO20	25
17.5. Modulating humidifier with HRO20 and SHR10 or SHC80.....	26

1. Presentation

1.1. Description of accessories supplied with the SKR humidifier with a Space Distribution Unit (SDU) module.

The following accessories are supplied along with the ones corresponding to kit option:

- 1 female fitting and a braided hose to connect the water supply.

	Accessories	Part #	Kit ROO	Kit ROW
Controls	Room humidity controller	HRR100	Included	Included
	Window temperature sensor	OTW	----	Included
Cable	3m (10') control cable	SP 9047	1 length included	1 length included

Kit N includes terminals for the connection of controls other than those mentioned in the above table, please contact Neptronic for additional information about this option

1.2. SKR with SDU module overview

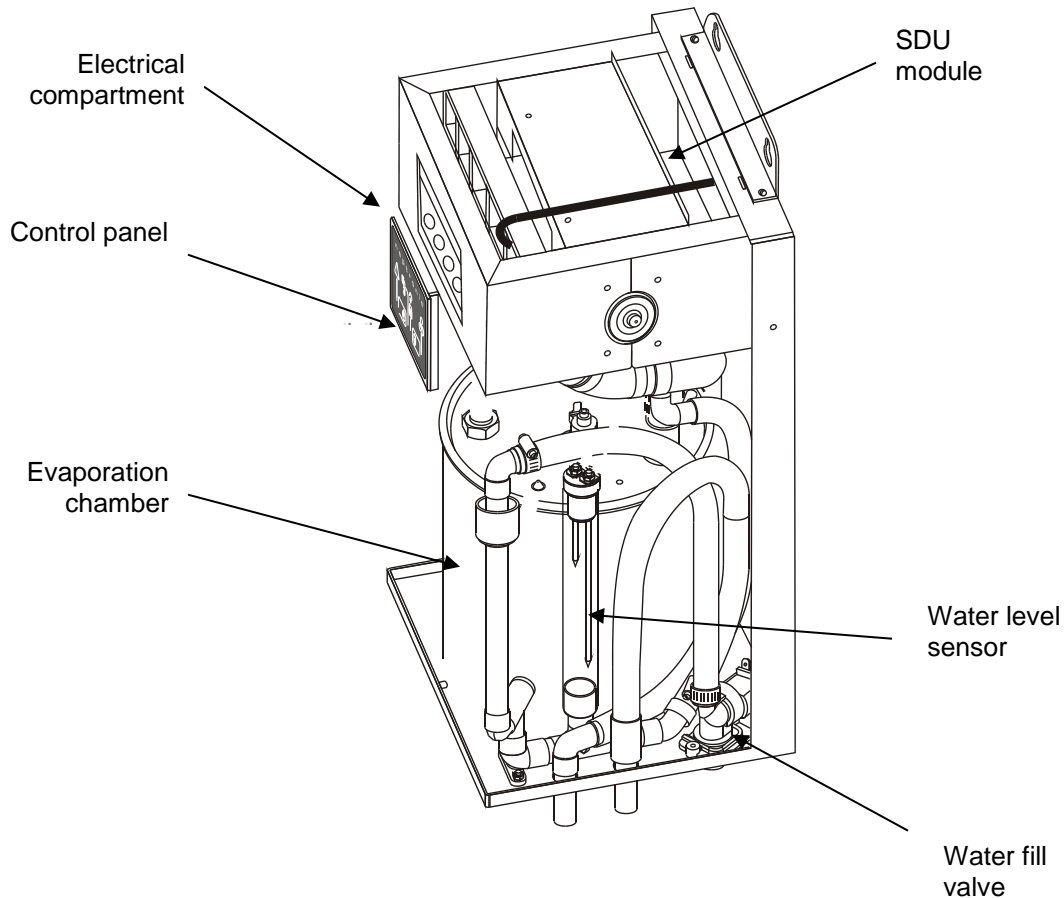

(Fig. 1)

SDU module option is available only along with kit R or N. Kit D or S is non-compatible because no air duct is present. Please note that the APS supplied with standard Kit R will be substituted for an Air flow proving switch integrated into the **SDU** module.



1.3. Numbering system

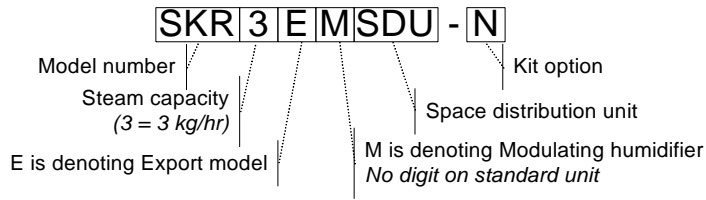

2. Definition

2.1. Evaporation chamber

Assembly including the stainless steel cylinder and a cover equipped with an electric element.

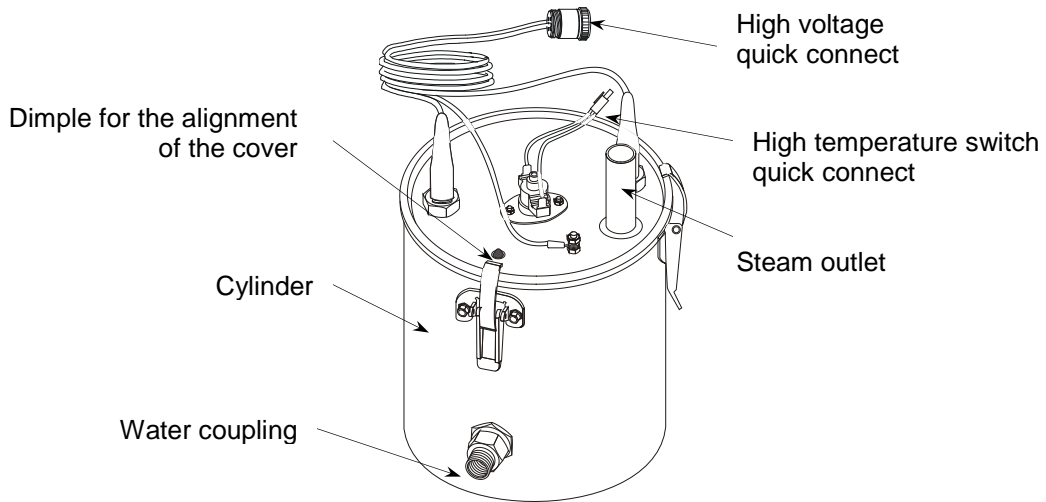

(Fig. 2)

3. Characteristics

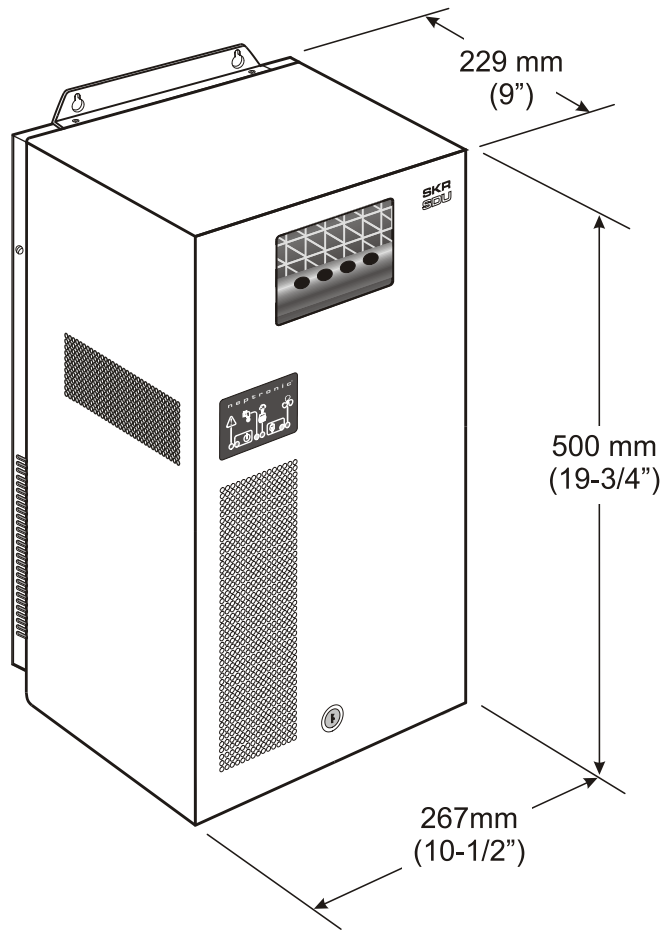

(Fig. 3)

Model with SDU	Capacity kg/hr (lb/hr)	Electrical Requirements			Steam outlet diameter mm (in)	Weight kg (lb)	
		Voltage (V)	Current (A)	Power (KW)		Empty	With water
SKR3E	3.0 (6.6)	230	10	2.3	35 (1-3/8")	16 (36)	23 (50)
SKR4E	3.75 (8.2)	230	12.2	2.8	35 (1-3/8")	16 (36)	23 (50)
SKR5E	5.0 (11.0)	230	16.1	3.7	35 (1-3/8")	16 (36)	23 (50)

4. Mechanical installation

4.1. General recommendations

- **CAUTION: RISK OF ELECTRIC SHOCK. DISCONNECT THE HUMIDIFIER FROM THE ELECTRIC SUPPLY BEFORE PROCEEDING TO THE MECHANICAL INSTALLATION.**
- **IMPORTANT:** Mechanical installation should conform to Local and National Codes.
- Location: Plan a location which is easy to access in order to permit a proper inspection and servicing of the humidifier.
Do not install humidifier where failure of the appliance could cause damage to the building structure or to costly equipment.

This location should be well ventilated; the ambient temperature should not exceed 30°C (85°F).

4.2. Positioning

- The front panel and the left side (electrical compartment) should be accessible in order to permit easy servicing of the humidifier. Leave a minimum clearance of 0.91m (36") from the front panel, 0,30m (12") from the left side, 0.15m (6") from the right side and 0.46m (18") above the humidifier.
- The **SKR-** humidifier with **SDU** module should be mounted 1 to 1,2m (39" to 47") above floor for the installation of water supply, drain piping and electrical connections.

4.3. Wall mounting

- **IMPORTANT:**
 1. Risk of malfunction. The humidifier must be level.
 2. Risk of overheating. Do not block the ventilation openings located on the top, front, sides and rear of the cabinet.
- Check the solidity of the chosen support or wall (bricks, concrete, stud partition wall, etc) on which the humidifier will be mounted (see page 5 for the weight of the unit).
- Use the keyholes located on the back panel of the **SDU** module wall mounting plate.
- Drill holes for the upper anchors (holes with eyelets) into the support or wall as per dimensions specified in the table (fig. 4). Holes dimensions (diameter and depth) should be in accordance with the recommendations of the chosen anchors.
- If necessary, install bolt anchors.
- Insert the 2 upper screws (holes with eyelet) of a minimum diameter of 6mm (1/4") (screws are not supplied).
- Leave a clearance between screw heads and wall in order to permit the mounting of the **SDU** wall mounting plate.
- Hang the **SKR-SDU** humidifier on the 2 upper screws.
- When the **SKR-SDU** humidifier is positioned on the screws, insert the lower screw. Then tighten all screws to secure the humidifier.

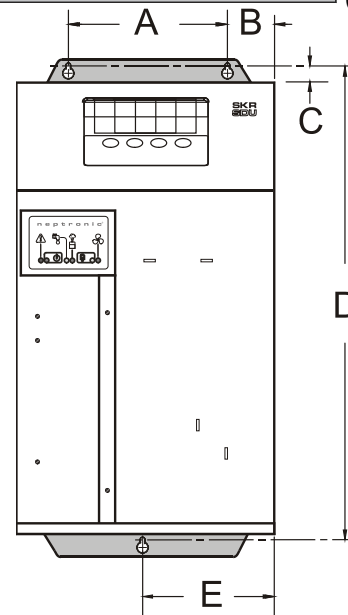
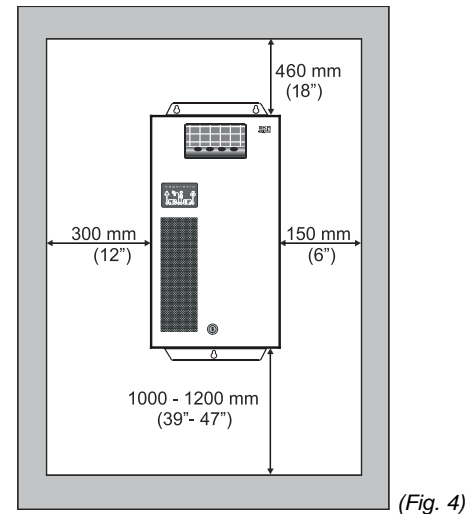

(Fig. 5)
Front view

Dimensions mm (in)	SKR-SDU
A	162 (6-3/8)
B	50 (2)
C	21 (53/64)
D	489 (19-1/4)
E	133 (5-1/4)

5. Steam connection

5.1. Typical installation

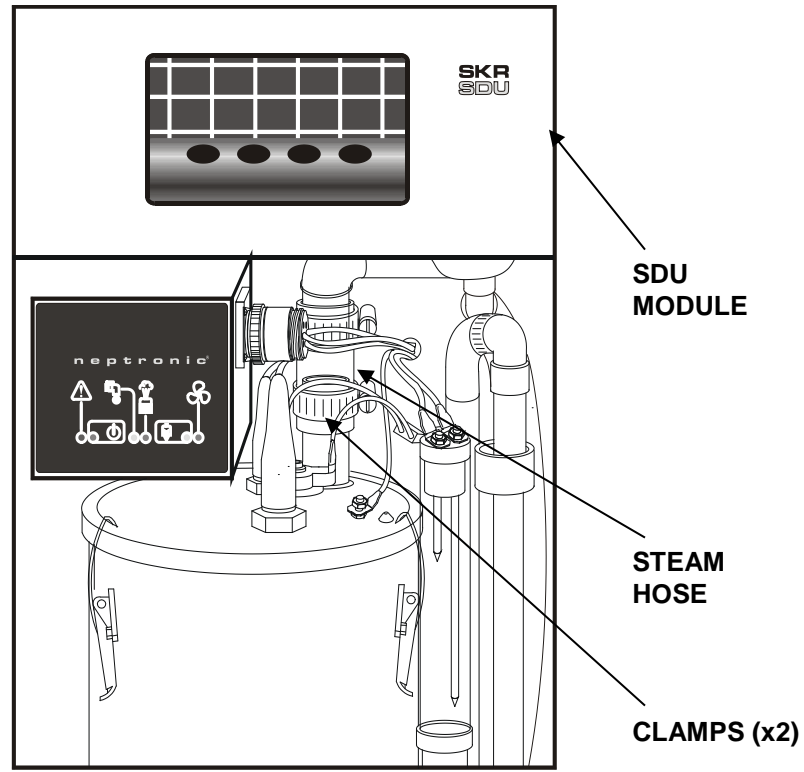

(Fig. 6)

A silicone tubing (steam hose) is inserted between the steam outlet of the evaporation chamber and the steam manifold assembly of the **SDU** module. Verify that the clamps are tight at both end of the silicone tubing to prevent leaks.

6. Plumbing connections

The **SKR** humidifier can operate with soft or hard water. Therefore, for normal operation, no pre-treatment of water is necessary.

IMPORTANT: Plumbing installation should conform to Local and National Codes.

6.1. Water supply

- Water inlet specifications:
 - ✓ **IMPORTANT: Risk of malfunction, do not use demineralized water.**
 - ✓ Inlet water pressure: 1 to 4,8 bars (15 to 70 psig)
 - ✓ **IMPORTANT: Risk of malfunction. Do not reduce water supply flow.**
 - ✓ Maximum temperature: 30°C (85°F)
 - ✓ 15mm (1/2") standard copper supply water connection
- To facilitate servicing, a shut off valve (not supplied) should be installed in the water supply line, close to the humidifier.
- It is recommended to install a standard strainer in the water supply line.
- If required, an air chamber made of copper pipe (see fig. 7) will absorb hydraulic shock, avoiding water hammer, when the fill valve closes. There are other standard types of air chambers commercially available.

Please follow the steps below:

1. Connect 15mm (1/2") copper pipe to the 15mm (1/2") braided hose (supplied).
2. Hand tighten the swivel top 20mm (3/4") fitting to the male threaded valve connection.
IMPORTANT: Risk of damage to the valve, do not use wrench to tighten swivel.

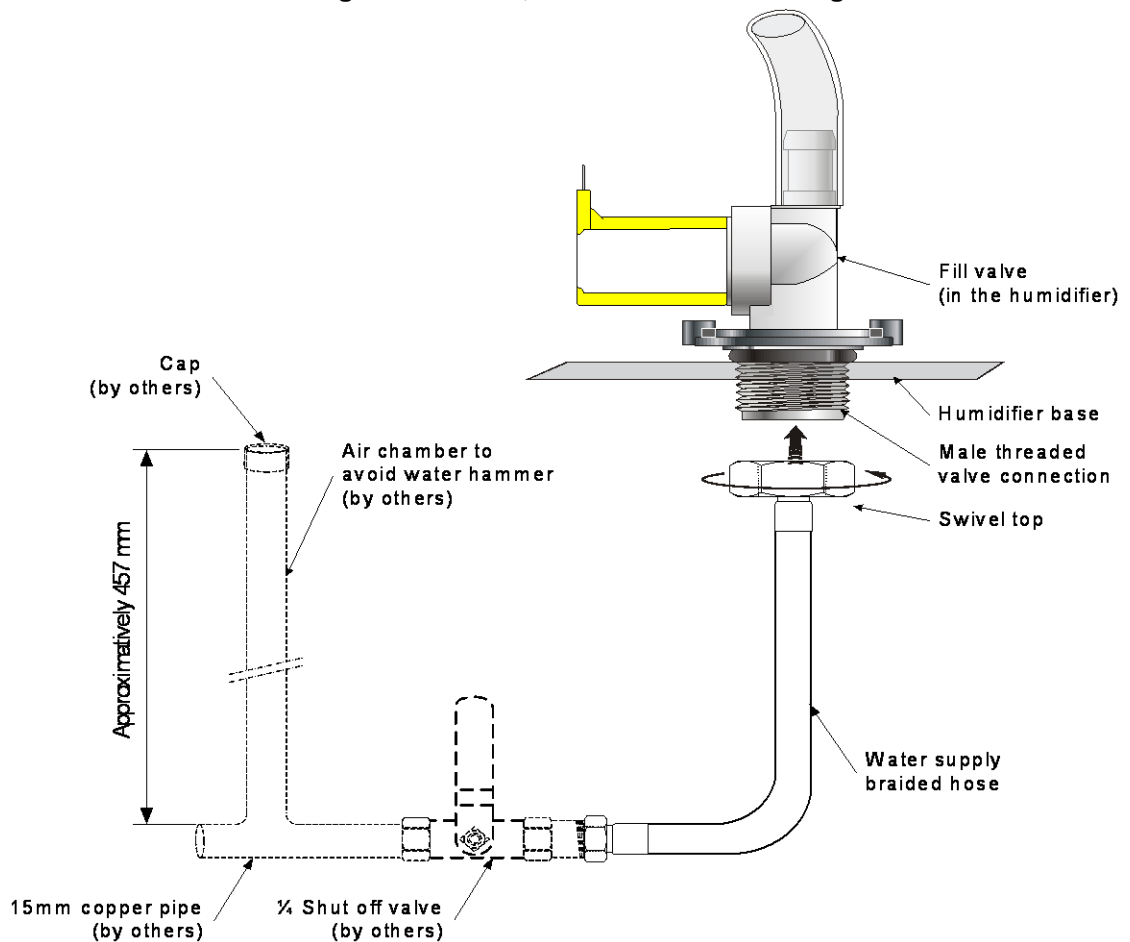

(Fig. 7)



6.2. Drain connections

- **IMPORTANT: No external drain traps are required.**
- Drain outlet specification:
 - ✓ Main drain 13mm (1/2") standard copper (evaporation chamber).
 - ✓ Pan drain 13mm (1/2") standard copper.
 - ✓ Water drain temperature: 60°C (140°F).
- **Two pipes minimum 25mm (1")** (by others) must be inserted over the humidifier outlet pipes (fig.8). This will create a critical air gap at the drain connections.
NOTE: This air gap is critical for normal drain siphon operation.

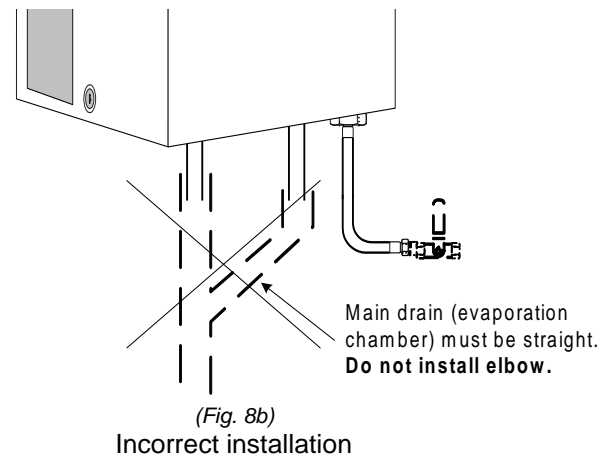
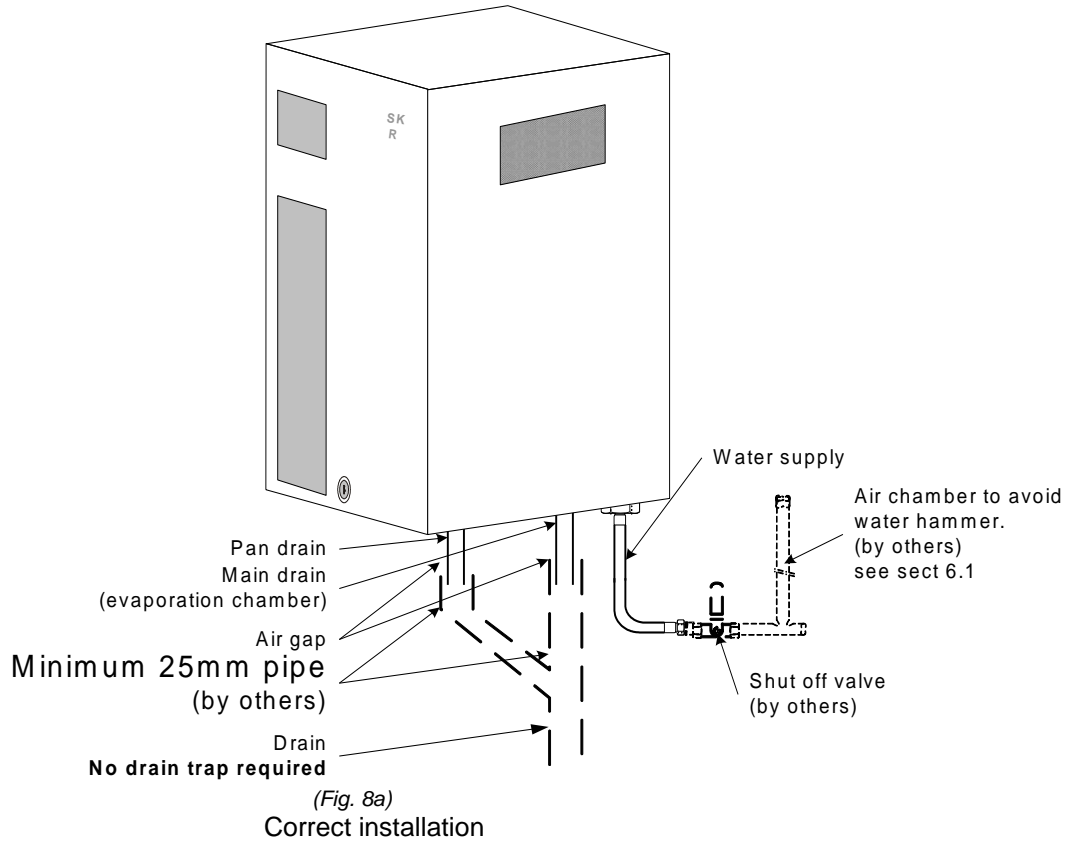

7. Power supply connections

- **CAUTION:**
 1. **RISK OF ELECTRIC SHOCK, TURN OFF POWER AT THE EXTERNAL BREAKER/FUSED DISCONNECT BEFORE PROCEEDING TO THE POWER SUPPLY CONNECTION.**
 2. **To reduce the risk of electric shock, do not connect to a circuit operating at more than 150V to ground.**
- **IMPORTANT:** The wiring to the humidifier should be done by a qualified electrician and conform to procedures, regulations and local codes.
- Ensure that the voltage required by the humidifier is the same as the available power supply.
- Ensure that the size of the wire conductors is appropriate for the current required by the humidifier.
- A dedicated external breaker/fused disconnect must be installed.
- The ground conductor must be equipped with ring terminal and be connected the indicated location (fig. 9).
- Use coppers conductors only.
- Ensure that each terminal connection is properly secured.
- Install the supplied strain relief bushing at the bottom of the electrical compartment for of the supply cable.

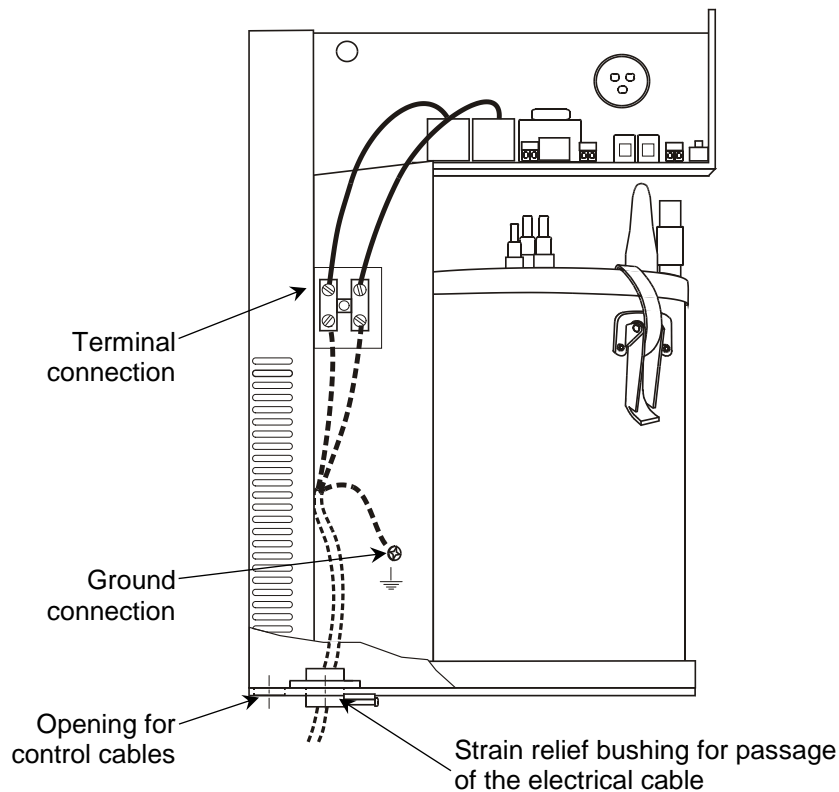

(Fig. 9)
 Left side view

8. Control panel display

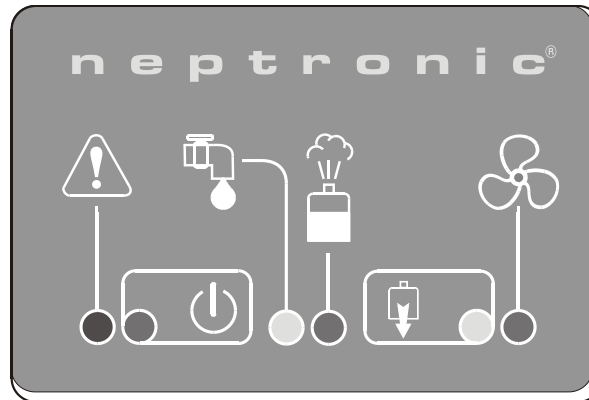

(Fig. 10)
Front panel



"ALARM" Indicator (red)

⊃○⊂ flashing	One or more abnormal conditions exist. (see section 15-Types of alarm)
⊃○⊂	Maintenance is required, the humidifier is OFF.
○	Normal operation.



"POWER" Push button and Indicator (green)

⊃○⊂	The push button is in the ON position.
⊃○⊂ slow flashing	The push button is in the OFF position and the humidifier is powered. (1 flash every 15 seconds).
○	Humidifier is not supplied with electric power.



"FILL" Indicator (yellow)

⊃○⊂	Water supply valve is open.
○	Water supply valve is closed.



"STEAM" Indicator (green)

⊃○⊂	Humidifier is producing steam at 100% capacity
⊃○⊂ flashing	Modulating humidifier only: Humidifier is modulating steam output according to the demand. Frequency of flashing is in proportion to the percentage of steam output.
○	Humidifier is not producing steam.



"DRAIN" Push button and Indicator (yellow)

⊃○⊂	Humidifier is in automatic or manual drain mode. <i>Press "DRAIN" push button to stop an on-going drain cycle.</i>
○	Drain mode is off.



"FAN" Indicator (green)

⊃○⊂	The contact to activate the ventilation system fan is closed.
○	The contact to activate the ventilation system fan is open.

9. Description of the SKR control PC Boards

- The Printed Circuit Board is equipped with an advanced microprocessor, which controls all humidifier functions.
- IMPORTANT:** Certain features on the **SKR** pc board cannot be used when the humidifier is integrated along with a **SDU** module.

P.C. Board for SKR-SDU with kit ROO and ROW

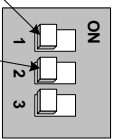
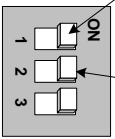
TB7	High voltage terminal blocks L, N and power supply to heating element.
TB1	Power supply to SDU fan.
TB3	Dry contact (TB3) for remote alarm annunciation. (1A, 24 Vac).
TJ1	Telephone jack Terminal (TJ1) to connect Room humidistat (HR).
TB6	Terminal (TB1) to connect the window temperature sensor (OTW).
DS1	<p>Dip switch (DS1) settings:</p> <p>Drain every 2 hours of operation</p> <p>"Service required" alarm appear after 750 hours of operation</p>  <p>Drain every 6 hours of operation</p> <p>"Service required" alarm appear after 1500 hours of operation</p>  <p>(Fig 11b) Dip switch setting</p> <p>DS1: Dip switch #3 is not used.</p> <p>Note: Depending on the local water conditions, service of the humidifier may be required prior to the "service required" alarm setting (see section 14, Maintenance of the SKR Installation instructions & user manual).</p>

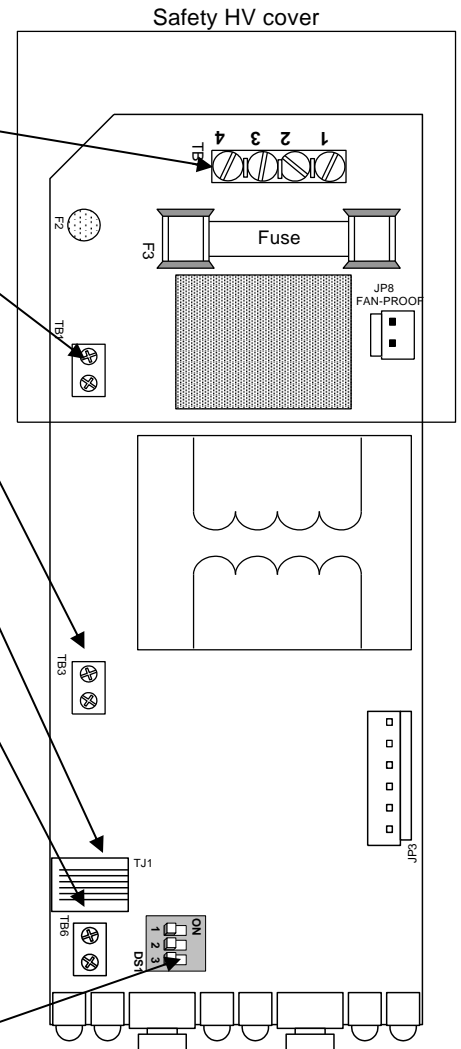

(Fig. 11)
P.C. Board top view

P.C. Board for SKR-SDU with kit N

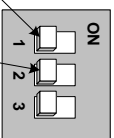
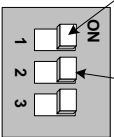
TB7	High voltage terminal blocks L, N and power supply to heating element.
TB1	Power supply to SDU fan.
TB3	Dry contact (TB3) for remote alarm annunciation. (1A, 24 Vac).
TB5	Terminal to connect the humidistat or Building Automation System (see fig.16).
DS1	<p>Dip switch (DS1) settings:</p> <p>Drain every 2 hours of operation "Service required" alarm appear after 750 hours of operation</p>  <p>Drain every 6 hours of operation "Service required" alarm appear after 1500 hours of operation</p>  <p>(Fig 12b) Dip switch setting DS1: Dip switch #3 is not used.</p> <p>Note: Depending on the local water conditions, service of the humidifier may be required prior to the "service required" alarm setting (see section 14, Maintenance of the SKR Installation instructions & user manual).</p>

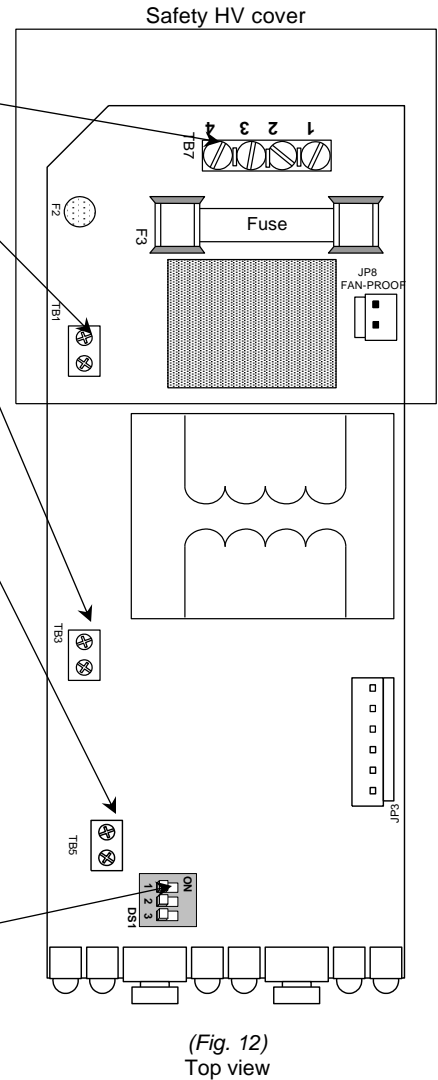

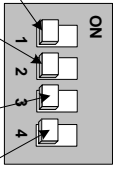

9.3. P.C. Board for modulating SKR-SDU with kit N

TB7	High voltage terminal blocks L, N and power supply to heating element.
TB1	Terminal to SDU Fan (TB1).
TB3	Dry contact (TB3) for remote alarm annunciation. (1A, 24 Vac).
TB5	Terminal to connect to an external cut off dry contact (see fig. 17).
TB6	Terminal to connect the humidistat or Building Automation System (see fig.17).
DS1	<p>Dip switch (DS1) settings:</p> <p>Drain every 2 hours of operation</p> <p>"Service required" alarm appear after 750 hours of operation</p> <p>No function attributed</p> <p>2-10 VDC control demand signal</p>  <p>Drain every 6 hours operation</p> <p>"Service required" alarm appear after 1500 hours of operation</p> <p>No function attribute</p> <p>0-10 VDC control demand signal</p> <p>(Fig 13b) Dip switch setting</p> <p>DS1: Dip switch #3 is not used.</p> <p>Note: Depending on the local water conditions, service of the humidifier may be required prior to the "service required" alarm setting (see section 13, Maintenance).</p>

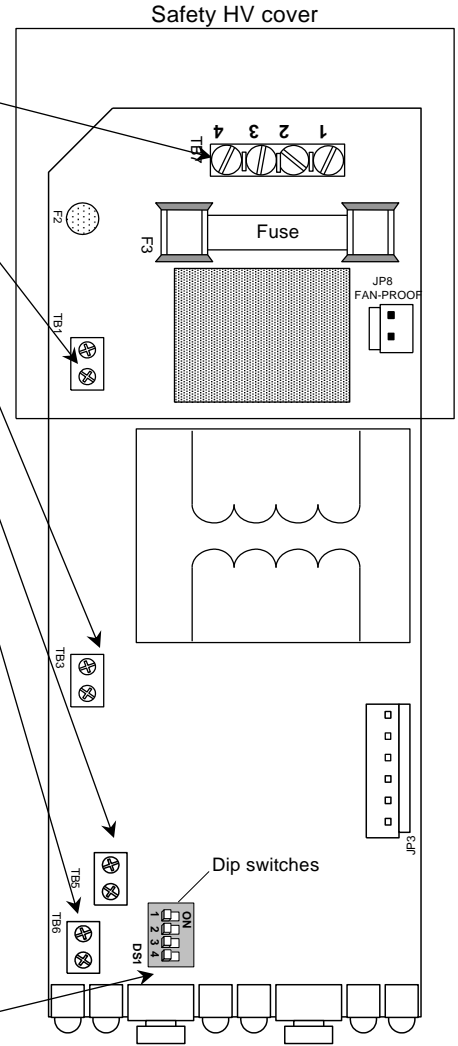

(Fig. 13)
Top view

10. Start up procedure

Follow this start-up procedure to avoid improper system operation:

1. Ensure that electrical and plumbing connections have been done in accordance with the instructions in this manual.
 - a) Remove the humidifier cover.
CAUTION: RISK OF ELECTRIC SHOCK, ENSURE THAT THE POWER IS TURNED OFF BEFORE REMOVING THE COVER.
 - b) Ensure that the control wiring has been made in accordance with the instructions in this manual.
 - c) Ensure that dip switches (section 9, DS1) are correctly set.
 - d) Verify that the drain connections are connected to an open main drain of sufficient diameter.
 - e) Re-install the humidifier cover.
2. Open the water shut off valve (external to the humidifier).
3. Turn on the power to the humidifier at the breaker/fused disconnect. The "**POWER**" indicator, located on the control panel, will flash.
4. Press the "**POWER**" push button located on the control panel. The "**POWER**" indicator will stay on continuously.
5. Perform a manual cleaning cycle:
 - a) The fill cycle is activated automatically when the evaporation chamber does not contain water.
 - b) When the "**FILL**" indicator is off, press the "**DRAIN**" push button.
 - c) The "**DRAIN**" indicator will come on and the water will drain from the evaporation chamber.
 - d) The evaporation chamber will fill with water and drain again.
 - e) When the "**DRAIN**" indicator turns off, press on the "**POWER**" push button.
 - f) Repeat steps "b" through "e" one more time to ensure proper cleaning of the evaporation chamber.
6. Your humidifier is now fully operational. No other action is necessary; your **SKR** humidifier will produce steam upon demand from control(s).

11. Description of operation of the SKR

- Press the "**POWER**" push button (if the indicator is flashing) to start the humidifier ("**POWER**" indicator will light continuously). If the evaporation chamber does not contain water, the fill cycle is activated automatically ("**FILL**" indicator is on).
- If there is no demand from the humidity controller, the humidifier is in a standby mode ("**STEAM**" indicator is off).
- On a demand of humidity, the contact to activate the ventilation system fan closes ("**FAN**" indicator is on) and the relays close to power the electric element in the evaporation chamber ("**STEAM**" indicator is on).
- The water in the evaporation chamber will start to boil and evaporate. The steam is released through the opening in the cover of the evaporation chamber. The steam will travel in the flexible steam hose and disperse into the space by fan assembly of the SDU through the steam manifold.
- During the evaporation sequence, a certain amount of water is evaporated. The water supply valve will open to replenish the water in the evaporation chamber.
- Depending on the selected drain period (section 9, DS1-1), the water in the evaporation chamber will be drained ("**DRAIN**" indicator is on) to renew the water and to evacuate the minerals inside the evaporation chamber.
- The **SKR** operates at full capacity until the programmed humidity level set point is reached. When the set point is reached, the humidifier will revert to standby mode. The contact to activate the fan assembly will remain closed for a period of four minutes after steam production has stopped.
- When the humidity level is below the set point, the humidifier will produce steam again. If there is no humidity demand for a period of more than 72 hours, the humidifier will drain the water from the evaporation chambers automatically and go into standby mode

12. Shut-down procedure

During seasonal shut down, the humidifier should be placed out of service.

1. Press "**DRAIN**" push button to empty the water from the evaporation chamber, the "**DRAIN**" indicator will be on.
2. Once the cycle has ended, the "**DRAIN**" indicator will turn off. Close the shut off valve (external to the humidifier) on the water supply line.
3. Open the main power breaker/fused disconnect switch to the humidifier.

13. Maintenance

13.1. General

- **IMPORTANT:** Failure to perform the required periodic maintenance will void the warranty.
- The required cleaning frequency can vary from every 2 months to once a year depending on local water conditions.
- The **SKR** humidifier is equipped with an internal operating hour counter and a "service required" alarm. Depending on the local water conditions, service of the humidifier may be required prior to the "service required" alarm setting (section 9, DS1-2).
- The routine service is a cleaning of the evaporation chamber.

13.2. Evaporation chamber cleaning

CAUTION: RISK OF BURN. THE EVAPORATION CHAMBER AND ITS CONTENTS CAN BE EXTREMELY HOT, CHECK TEMPERATURE BEFORE HANDLING.

1. Cooling down and draining of the evaporation chamber.

- a) Press "**DRAIN**" push button on the control panel. The humidifier will initiate a drain cycle. The "**DRAIN**" indicator will turn on.
- b) The "**DRAIN**" indicator is on and the water is drained from the evaporation chamber.
- c) The evaporation chamber will refill with water and drain again.
- d) When the "**DRAIN**" indicator turns off, the "**POWER**" indicator will begin to flash.
- e) Check the temperature of the evaporation chamber. If it is cool enough go to step #2 below, otherwise repeat draining of the evaporation chamber (step #1) until is cold enough.

2. Shut down of the electrical supply.

CAUTION: RISK OF ELECTRIC SHOCK, TURN OFF POWER AT THE EXTERNAL BREAKER/FUSED DISCONNECT BEFORE SERVICING.

- a) Remove the cover of the **SKR** Humidifier.

3. Disconnecting the heating element.

- a) Unscrew the high voltage quick connect (see fig. 2), located on the right side of the electrical compartment.

4. Disconnecting the high temperature switch.

- a) Disconnect the high temperature switch quick connect (see fig. 2).

5. Disconnecting the steam hose and the water pipe.

- a) Loosen clamp on the steam hose connection.
- b) Remove the steam hose from the top of the evaporation chamber.
- c) Unscrew the water piping coupling located on the lower right hand side of the evaporation chamber.

6. Removing the evaporation chamber.

- a) Remove the evaporation chamber from the humidifier cabinet.

7. Opening the evaporation chamber.

- a) Unfasten the 3 latches located around the evaporation chamber.

Caution: Risk of injury, latches are tight. It is recommended to use pliers or a screwdriver to unfasten the latches.

- b) Remove the cover from the evaporation chamber.
- c) Do not misplace the gasket located between the cover and the cylinder.

**8. Cleaning the evaporation chamber.**

- a) Pour out any remaining water and scale from the bottom of the evaporation chamber
- b) Clean out the remaining scale, use a non-metallic brush and water. Some vinegar or any weak acid for cleaning stainless steel may be required.

IMPORTANT: The use of wire brush or any non-recommended acid will void the warranty.

- c) If the amount of scale to be removed is significant, the service required alarm setting and/or the drain rate (section 9, DS1-1) may be set too high for the local water conditions. Too much scale may impair the normal operation of the humidifier or damage it. In this case, increase the frequency of maintenance as necessary.

9. Cleaning the electric element and cover.

- a) The cover of the evaporation chamber and element will, in general, not require cleaning. However, if cleaning is required, proceed as per the cleaning of the evaporation chamber.

IMPORTANT: The use of wire brush or any non-recommended acid will void the warranty.

10. Checking the gasket

- a) Check the gasket. The gasket should not be cracked.
The gasket must be replaced a minimum at every second maintenance of the evaporation chamber or after one year of operation. Replace more frequently if required.

11. Reassembling the evaporation chamber.

- a) Rinse out the cylinder and the cover with water.
- b) Place the gasket inside the cover before installing the cover on the evaporation chamber.
- c) Align the dimple on the cover with the latch located nearest to the water drain/fill coupling (fig.2).
- d) Tighten the three latches around the cover.
- e) Replace the evaporation chamber in the humidifier.
- f) Tighten the water drain/fill coupling.
- g) Replace the steam hose on the outlet of the evaporation chamber and secure steam hose with the clamp.
- h) Reconnect the high temperature switch connector and the high voltage connector of the heating element.

CAUTION: RISK OF OVERHEAT AND FIRE, MAKE SURE THE HIGH VOLTAGE CONNECTOR IS PROPERLY LOCKED.

- i) Replace the cover on to the humidifier and lock it.

12. Start-up of the humidifier.

- a) Close the main power breaker/fused disconnect switch to the humidifier.

Reset of the operating hours to zero: Press "POWER" push button to turn OFF the humidifier, if necessary, then press and hold the "POWER" and "DRAIN" push buttons for ten seconds (section 15-Types of alarm, Reset).

- b) Press the "POWER" push button. The "POWER" indicator on the control panel will light.
- c) The humidifier will go into a fill cycle; the "FILL" indicator will be on.
- d) If there is a humidity demand, the humidifier will produce steam.

13.3. Maintenance of the SDU module

- The SDU module is maintenance free. No maintenance is required.

14. Exploded View and Bill of Material

14.1. Exploded view of the SDU module

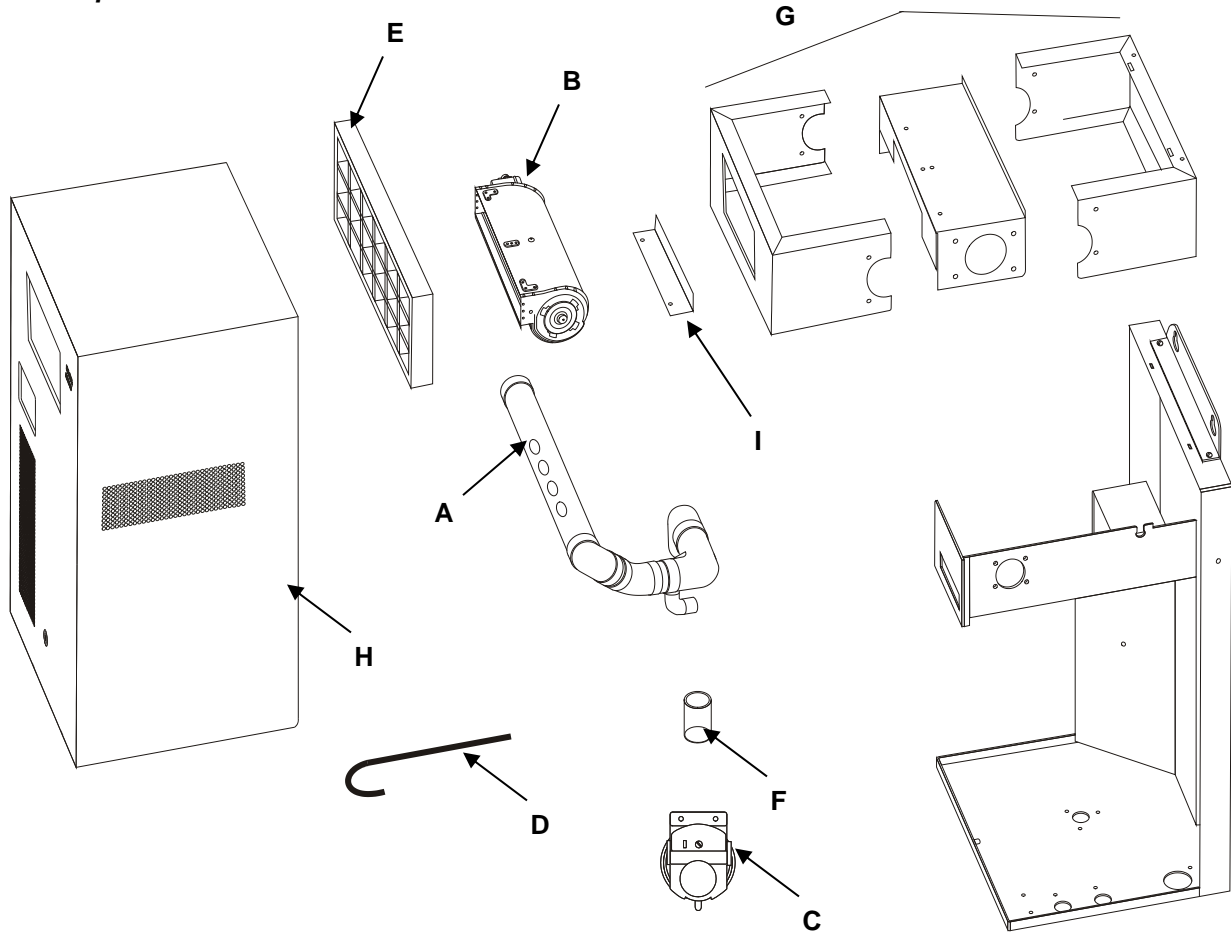

(Fig. 14a)

14.2. Bill of Material of the SDU module

Item	Description	Model	Part number
A	SDU manifold	SKR-3E / 4E / 5E	SW PIPESDUR-ASSY
B	Fan assembly	SKR-3E / 4E / 5E	SP 3012
C	Air pressure switch	SKR-3E / 4E / 5E	SP PSA-01
D	Pitot tube assembly	SKR-3E / 4E / 5E	SW SDUR-PITOT
E	SDU Grill	SKR-3E / 4E / 5E	SP SDUR-GRILL
F	Silicone tubing	SKR-3E / 4E / 5E	SP 1026
G	SDU cabinet	SKR-3E / 4E / 5E	SP 9005
H	SDU cover	SKR-3E / 4E / 5E	SP 9004
I	SDU Grill support	SKR-3E / 4E / 5E	SP9005-6



Exploded view of SKR

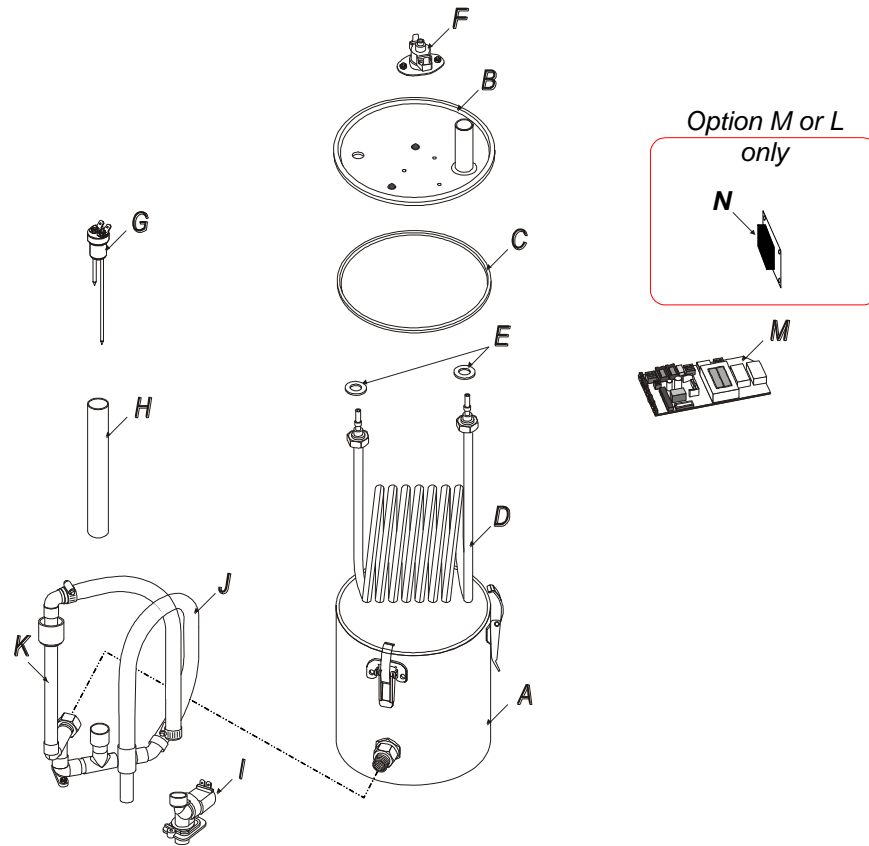

(Fig. 14b)

14.4. Bill of Material of SKR

Item	Description	Model	Part number
A	Evaporation chamber cylinder	SKR-3E / 4E / 5E	SW SKRCONT-ASSY
B	Evaporation chamber cover	SKR-3E / 4E / 5E	SP 9012-M
C	Evaporation chamber gasket	SKR-3E / 4E / 5E	SP 9030
D	Heating element	SKR3E	SE 5991
		SKR4E	SE 5992
		SKR5E	SE 5993
E	Heating element gasket	SKR-3E / 4E / 5E	SP 1005
F	High temperature switch	SKR-3E / 4E / 5E	SP 3035
G	Water level sensor assembly	SKR-3E / 4E / 5E	SW SKRLEV-ASSY
H	Water level sensor tube	SKR-3E / 4E / 5E	SP 1025
I	Water fill valve	SKR-3E / 4E / 5E	SP 6004
J	Drain pipe assembly	SKR-3E / 4E / 5E	SW SKRDRAIN-ASSY
K	Main plumbing assembly	SKR-3E / 4E / 5E	SW SKRPIPE-ASSY
M	Main PC board kit R	SKR-3E / 4E / 5E	NW SKRESMAINSS
	Main PC board kit N- ON/OFF	SKR-3E / 4E / 5E	NW SKRESMAIN-NSS
	Main PC board kit N- Modulating	SKR-25M / 30M / 40M	NW SKRES-M-NSS
N	SKR-TRIAC PC board (option M)	SKR-3EM / 4EM	NW SKRET-2SS
		SKR-5EM	NW SKRET-3SS
	SKR-TRIAC PC board (option L or ML)	SKR-3E / 4E	NW SKRL-2SS
		SKR-5E	NW SKRL-3SS

15. Types of alarm

CAUTION: RISK OF ELECTRIC SHOCK, POWER MUST BE TURNED OFF AT THE EXTERNAL BREAKER/FUSED DISCONNECT BEFORE REMOVING THE COVER OF THE HUMIDIFIER.

- **IMPORTANT:** A corrective action must be taken before doing a reset.
- The alarm contact (normally open) will close when there is an alarm.

ALARM Indicator	Condition	Consequences	Corrective actions	Reset
Service required 1. Flashing continuously	Operating hours exceeded the service required alarm hour setting (DS1-2)	Alarm. No interruption of the operation of the humidifier	Proceed to a service (See section 13-Maintenance)	<ul style="list-style-type: none"> • Press the "POWER" push button to turn OFF the humidifier (if necessary). • Press and hold "DRAIN" and "POWER" push buttons simultaneously for ten seconds. These two indicators will turn on after the ten seconds. Release the push buttons.
Service required 2. Indicator is continuously on <i>(SKR Humidifier shut off)</i>	Operating hours exceeded by more than 50 hours the service required alarm setting (DS1-2)	Alarm. The operation of the humidifier is interrupted	Proceed to a service (See section 13-Maintenance)	
High temperature 2 flashes + pause	Temperature in the evaporation chamber exceeded the preset temperature of the high temperature switch	Alarm. The operation of the humidifier is interrupted	<ul style="list-style-type: none"> • Check that the steam hose is not blocked or kinked. • Check that the water connection on the evaporation chamber is not blocked. 	Press the reset button on the high temperature switch device located on the evaporation chamber cover.
Drainage 3 flashes + pause	Drainage sequence is not correct	Alarm. The operation of the humidifier is interrupted	<ul style="list-style-type: none"> • Check that the water connection to the evaporation chamber is not blocked. • Check that the drain piping is not blocked. 	Press on the DRAIN push button
Fill 4 flashes + pause	Time to fill the evaporation chamber exceeded the preset time in the microprocessor	Alarm. The power to the heating element is interrupted	<ul style="list-style-type: none"> • Check that the shut off valve installed on the supply water line is open. • Verify the operation of the fill valve. • Check that the fill valve strainer and the external strainer are not blocked. 	Automatic reset when the proper water level is reached
Level sensors 5 flashes + pause	The level sensors do not detect the water level correctly	Alarm. The operation of the humidifier is interrupted	<ul style="list-style-type: none"> • Check that the sensors are properly connected. • Check that the sensors are clean. 	Press on the POWER push button
Wall humidity controller 6 flashes + pause	Sensor not detected or not operational	Alarm. The power to the heating element is interrupted	<ul style="list-style-type: none"> • Check that the Neptronic supplied cable is connected between the HRR100 and the TJ1 terminal on the PC board of the SKR. 	Automatic reset when the humidity controller is detected
Power Not flashing	The unit is not powered	–	<ul style="list-style-type: none"> • Check that the main power breaker or fused disconnect switch is closed 	Automatic reset when the unit is powered

16. Troubleshooting guide for SDU module

Problem	Causes	Corrective actions
The humidifier does not operate (no alarm)	<ul style="list-style-type: none"> • The humidifier is not powered. • Airflow is not detected by the airflow proving switch. • The fan assembly of the SDU module is not operating. • The airflow proving switch is not operational. 	<ul style="list-style-type: none"> • Check for the main power supply and fuses. • Check that the sensor tube is connected properly to the pitot tube and to the airflow proving switch. • Check the fan operation. • Check that the SDU supplied cable is connected between properly on the PC board of the SKR. • If the fan is operating then check the airflow proving switch.
The humidifier does not operate (alarm indicator flashing)	<ul style="list-style-type: none"> • Check the alarm indicator to determine the cause 	<ul style="list-style-type: none"> • See section 15-Types of alarm to correct the situation.
Water droplets coming out of the SDU steam manifold	<ul style="list-style-type: none"> • The installation of the SDU module is not properly level. • Foaming condition is occurring inside the evaporation chamber. • Obstruction of the ventilation openings on the front cover of the SKR. 	<ul style="list-style-type: none"> • Check if the SKR-SDU unit is installed correctly. • Drain the SKR and verify if maintenance is required on the evaporation chamber. • Check if the ventilation openings are not blocked.

17. Electrical diagram

17.1. Electrical diagram for SKR with SDU module – Kit R

SKR humidifier

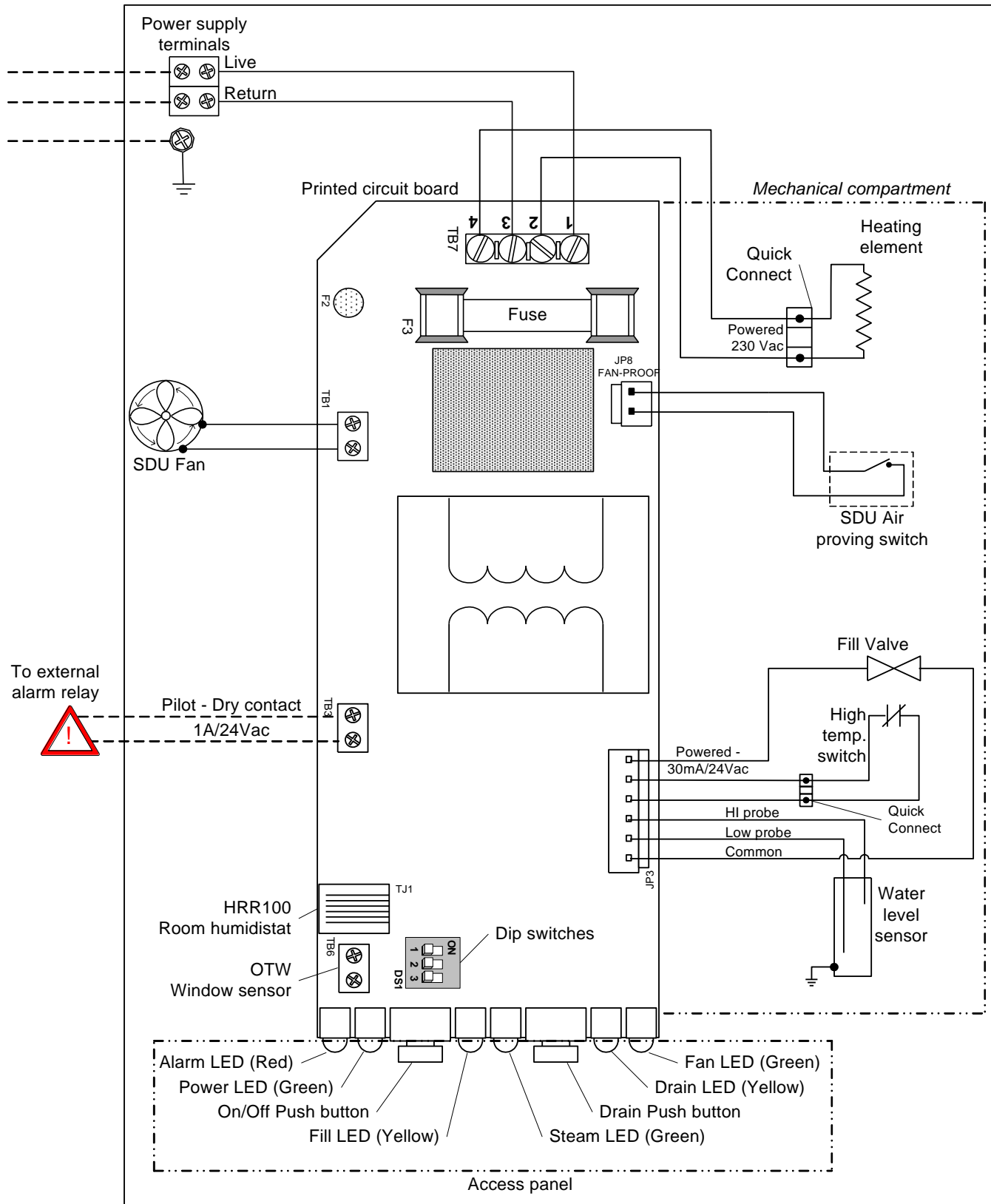

(Fig. 15)

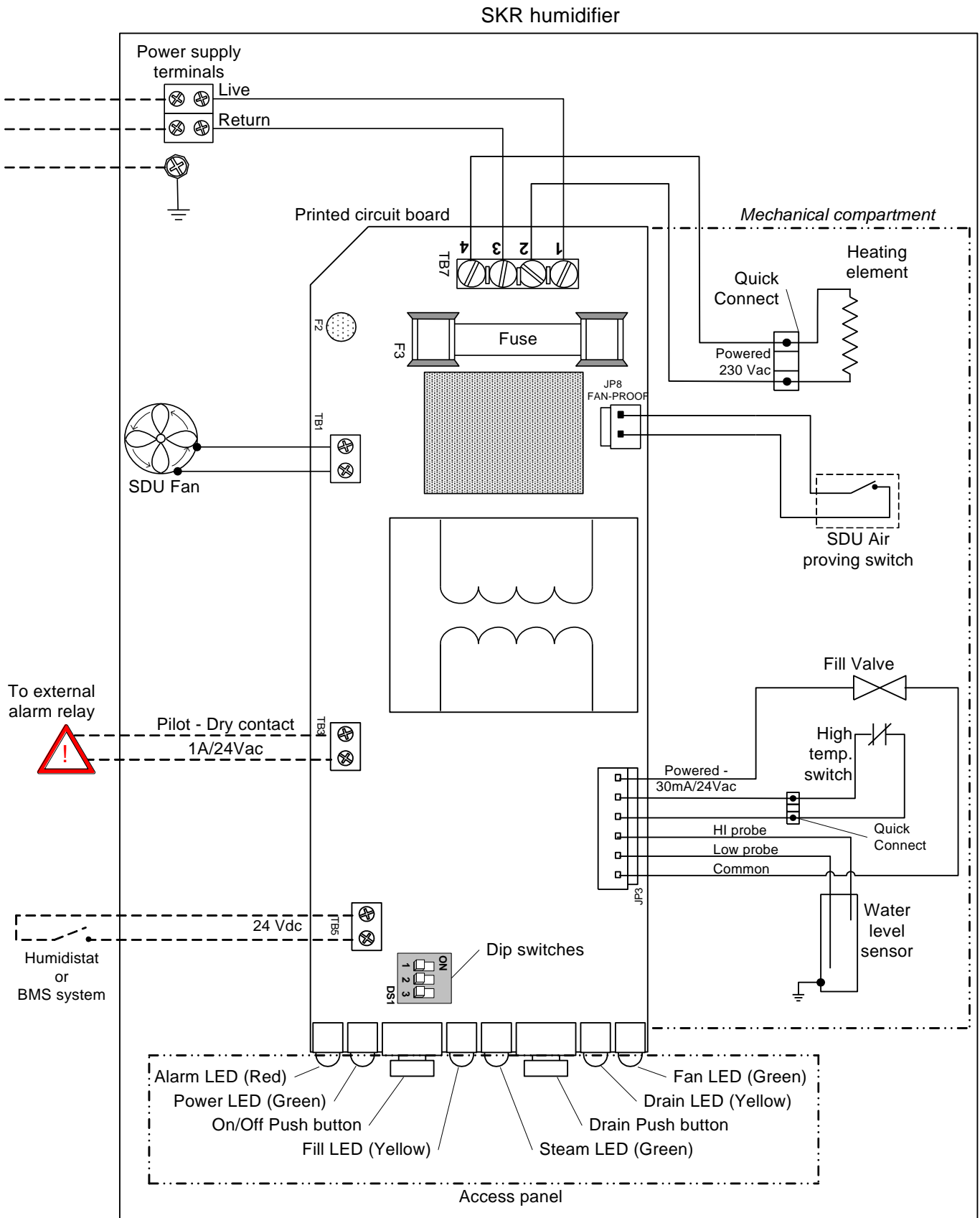
17.2. Electrical diagram for SKR with SDU module – Kit N

(Fig. 16)

17.3. Electrical diagram for SKR with SDU module – Kit M-N

SKR humidifier modulating - N

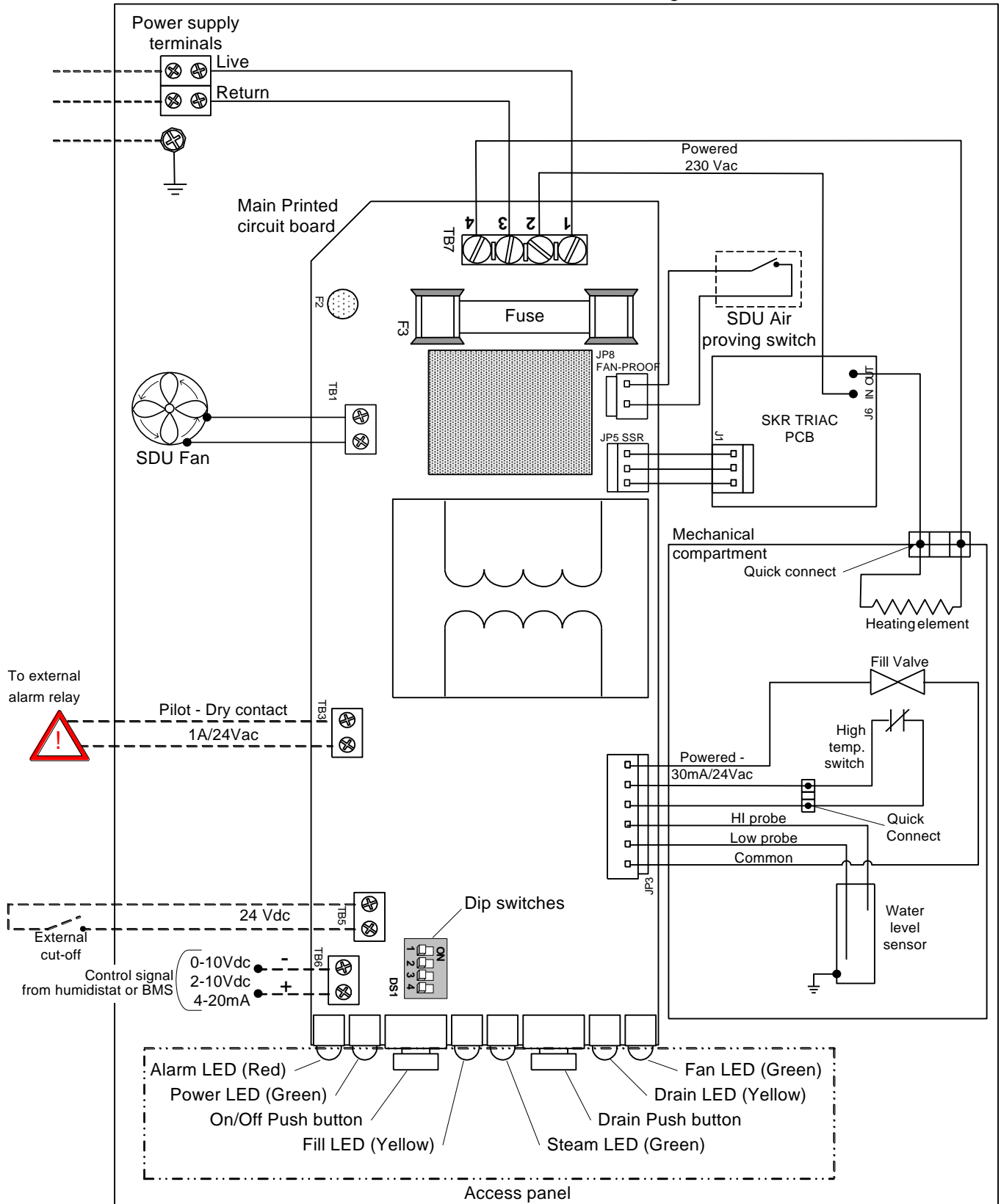

(Fig. 17a)

17.4. Modulating humidifier with HRO20

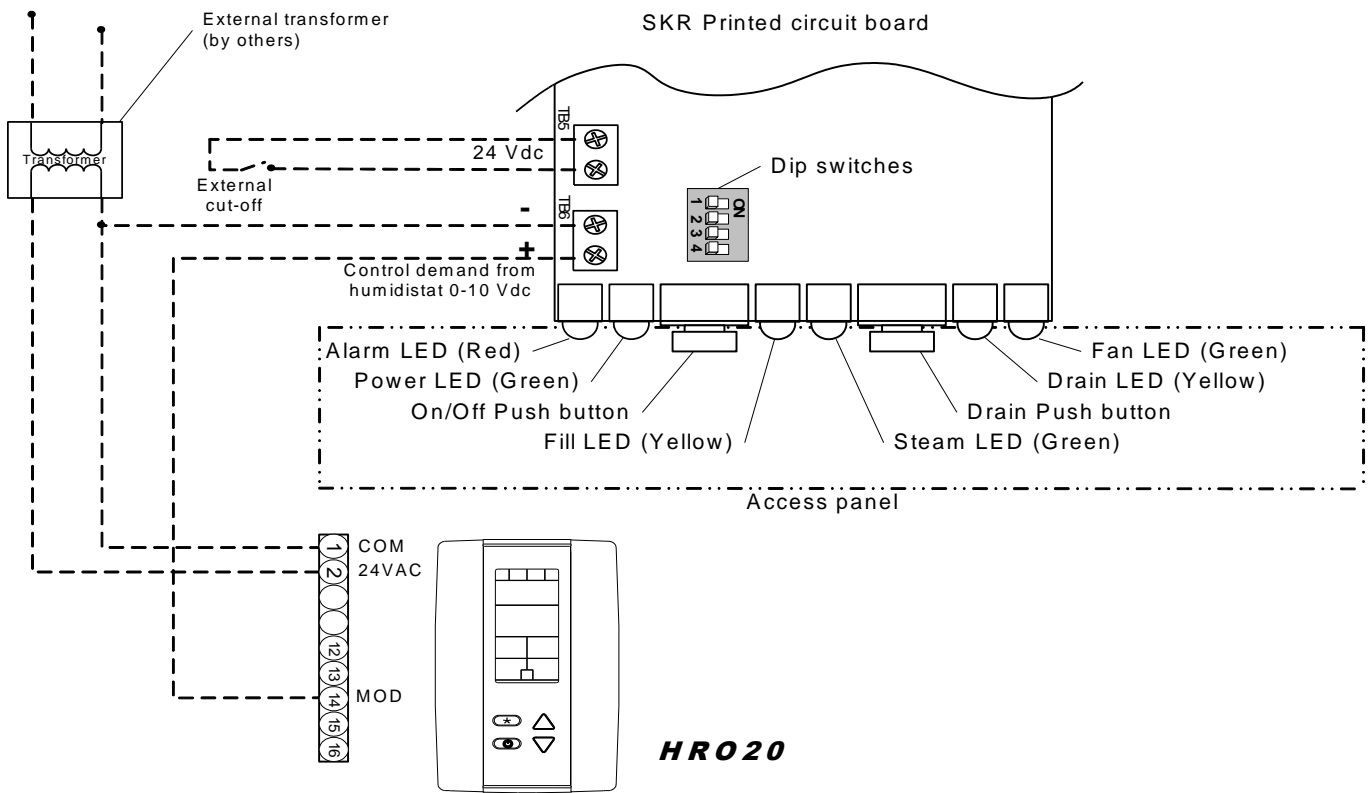

(Fig. 17b)

17.5. Modulating humidifier with HRO20 and SHR10 or SHC80

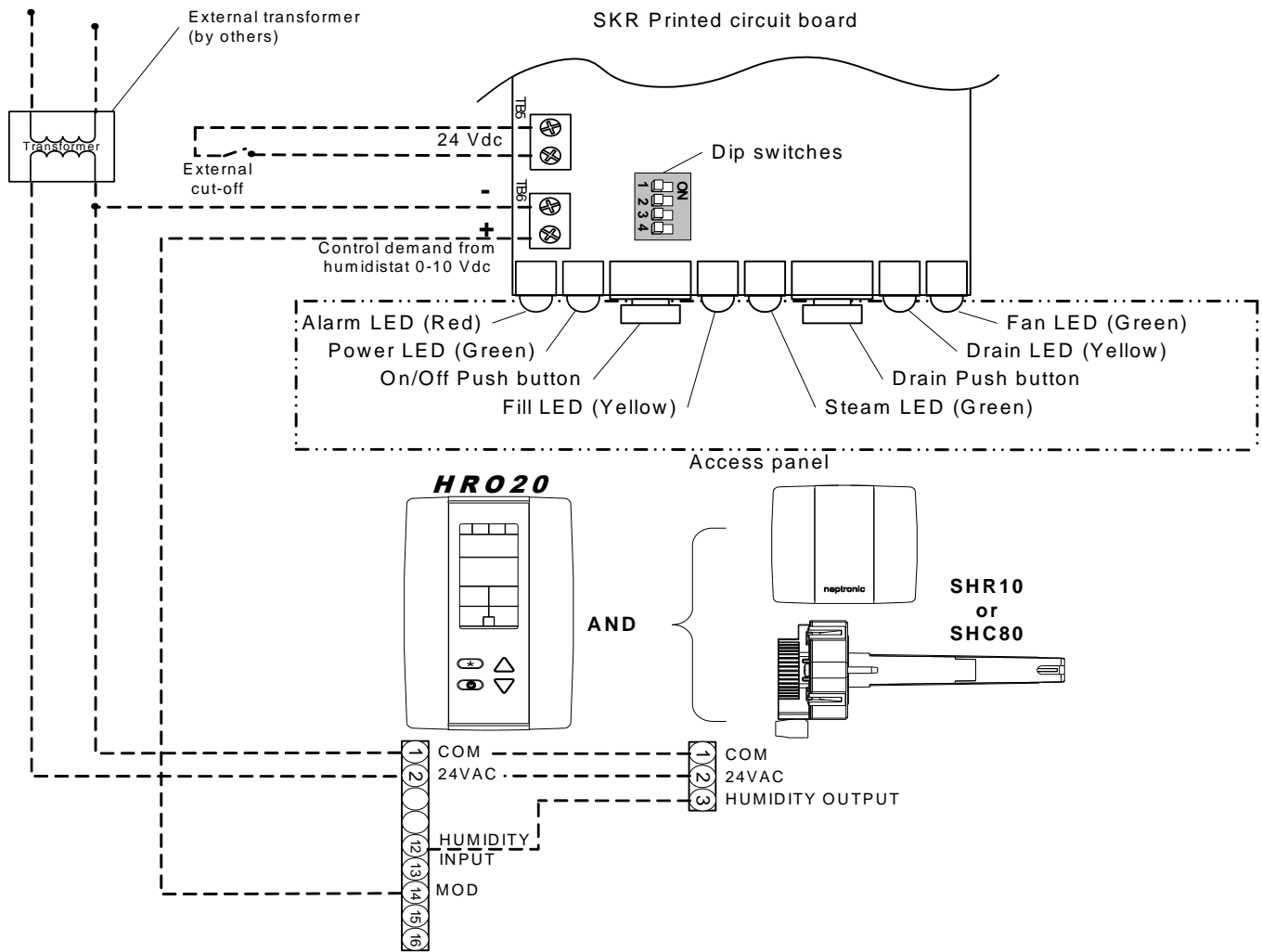

(Fig. 17c)



neptronic®

Head Office:

400 Lebeau Blvd., Montreal, Qc, H4N 1R6, CANADA

Tel.: (1) 514-333-1433

Fax: (1) 514-333-3163

Customer service Fax: (1) 514-333-1091

Toll free: 1 800-361-2308

Business hours: from Monday to Friday, 8:00am to 5:00pm (Eastern time).

US Office:

NEP Inc.

355 North Main Street, Suite 2, Hiawassee, Georgia, 30546, USA

Tel.: (1) 706-896-2466

Fax: (1) 706-896-0077

Toll free: 1 800-456-2735

www.neptronic.com

© 2017