



### Controller Models

- EVCB44NIT0S** (0 TRIACS / pressure independent)
- EVCB44NDT0S** (0 TRIACS / pressure dependent)

### TDU Series Digital Room Sensor

- TDU00** (Vertical Grey LCD, white enclosure)
- TDU30** (Vertical Black LCD, black enclosure)
- TDU60** (Vertical Black LCD, white enclosure)

- TDU10** (Horizontal Grey LCD, white enclosure)
- TDU40** (Horizontal Black LCD, black enclosure)
- TDU70** (Horizontal Black LCD, white enclosure)

### TRL Series Digital Room Sensor

- TRL24** (With temperature sensor)
- TRLH24** (With temperature and humidity sensor)
- TRLG24** (With temperature and CO<sub>2</sub> sensor)
- TRLGH24** (With temperature, CO<sub>2</sub>, humidity sensors)
- TRL54** (With temperature sensor)



EVCB44N Series Controller



TDU00 / TDU30 / TDU60 Series



TDU10 / TDU40 / TDU70 Series



TRL24 Series



TRL54 Series

## Contents

### EVCB44N Series Controller

- [Specifications](#)
- [Application Diagrams](#)
- [Mechanical Installation - Actuator](#)
- [Wiring](#)

### Digital Room Sensors

- [Models](#)
- [Specifications](#)
- [Dimensions](#)
- [Interface](#)
- [Mounting Instructions](#)

### Programming Mode Menus

- [Accessing the Programming Mode](#)
- [Navigating the Programming Menus](#)

### TRL24/TDU Programming Mode Menus

- [Pressure, Applications, Inputs, and Outputs](#)
- [Temp, Motor, Settings, and Ramps](#)
- [Network, Time, Buttons, and Options](#)

### TRL54/TDU Programming Mode Menus

- [Pressure, Applications, Inputs, and Outputs](#)
- [Temp, Motor, Settings, and Ramps](#)
- [Network, Time, and Buttons](#)

### Operation Mode Menus

- [Menu 372 – Temperature Offset - TRL24/TDU and TRL54](#)
- [Menu 637 – Network Settings - TRL24 and TDU](#)
- [Menu 757 – Airflow Balance Mode - TRL24 and TDU](#)
- [Menu 637 – Network Settings - TRL54](#)
- [Menu 757 – Airflow Balance Mode - TRL54](#)

### Reset to Factory Default Settings

### Runtime User Interfaces - Digital Sensors

- [TRL24 – Runtime User Interface](#)
- [TRL54 – Runtime User Interface](#)
- [TDU10/TDU40/TDU70 Series – Runtime User Interface](#)
- [TDU00/TDU30/TDU60 Series – Runtime User Interface](#)

### Operation Mode Settings

### Annex A: Control Apps

## EVCB44N Series Controller

### Overview

The EVCB44N Series Controller is a combination controller and digital room sensor with support for networked communications via the BACnet MS/TP or Modbus protocol. The EVCB44N Series Controller is compatible with TRL24, TRL54, and TDU series digital room sensors. The Networkable VAV Controller is designed for simple and accurate control of any variable air volume box in a number of zone control configurations. Its field configurable algorithms enable versatile implementation of required control sequences.

### Features

- Field configured VAV algorithms, inputs and outputs
- Built-in actuator, 70 lb-in
- On board differential pressure sensor (select models)
- Select direction on analog outputs
- Simple air balancing and commissioning via digital room sensor
- Automatically sets operation mode to pressure dependent or independent based on the presence of air flow
- Configurable PI (Proportional-Integral) function
- Independent, configurable proportional control band and dead band per ramp
- Selectable internal or external temperature sensor (10K $\Omega$ )
- Activate output with CO<sub>2</sub> sensor from TRL/TDU or external sensor input
- Changeover by external temperature sensor
- Internal and external temperature sensor calibration
- Freeze protection
- Fixed, elevator cage, screw terminals

### Operational Features

- Backlit LCD with simple icon and text driven menus
- Select digital room sensor's default display
- Network service port via on-board mini-USB connector
- Manual night setback or no occupancy override
- Multi level lockable access menu and setpoint
- Selectable Fahrenheit or Celsius scale
- 3-wire connection to controller and 4 push buttons

### Applications

- Single duct, cooling only
- Single duct cooling and/or heating
- Up to 2 analog (0-10Vdc) reheat and/or cool
- Pressure dependent or pressure independent
- With or without auto changeover
- Supply/exhaust (requires an additional EVC)

### Network Communication

- BACnet MS/TP or Modbus communication port
- Select MAC address via optional digital room sensor or network
- Automatic baud rate detection

### BACnet MS/TP<sup>®</sup>

- Automatic device instance configuration
- Copy & broadcast configuration via digital room sensor menu or via BACnet to other controllers
- BACnet scheduler
- Firmware upgradeable via BACnet
- Support COV (change of value)

### Modbus

- Modbus @ 9600, 19200, 38400 or 57600 bps
- RTU Slave, 8 bits (configurable parity and stop bits)
- Connects to any Modbus master

### Specifications

Description	EVCB44N Series Controller
<b>Torque</b>	70 in.lb. [8 Nm] at rated voltage
<b>Power consumption</b>	10 VA max
<b>Running time through 90°</b>	90 seconds
<b>Power supply</b>	22 to 26 Vac 50/60 Hz
<b>Inputs</b>	1 Universal input (Thermistor 10KΩ Type 3, contact (COM only), or 0-10Vdc)
<b>Outputs</b>	1 analog output (0-10 Vdc or 2-10Vdc; selectable)
<b>Real Time Clock</b>	Real-time clock (RTC) with super capacitor backup (approximately 3 days)
<b>BACnet</b>	BACnet® MS/TP @ 9600, 19200, 38400 or 76800 bps (B-ASC)
<b>Modbus</b>	Modbus RTU slave @ 9600, 19200, 38400 or 57600. Selectable parity and stop bit configuration: No parity, 2 stop bits   Even parity, 1 stop bit   Odd parity, 1 stop bit
<b>Electrical connection</b>	<b>Terminal Type:</b> 26~14AWG fixed elevator cage screw terminals <b>Power Wiring:</b> Insulated 2 core 0.8 mm <sup>2</sup> [18 AWG] minimum power cable. <b>Digital Room Sensor Wiring:</b> Insulated 3 core multi-strand 22 or 24 AWG cable. Maximum 50ft (15m) between controller and digital room sensor. <b>Communication Wiring:</b> Low capacitance, EIA RS-485, 22 or 24 AWG shielded twisted pair multi-strand cables (Belden 9841 or equivalent).
<b>Operating temperature</b>	0°C to 50°C [32°F to 122°F]
<b>Storage temperature</b>	-30°C to 50°C [-22°F to 122°F]
<b>Relative Humidity</b>	5 to 95% non-condensing
<b>Weight</b>	1.26 kg. [2.8 lb]
<b>Overall Dimensions (L x W x H)</b>	6 9/16" x 3 5/8" x 3" (166 mm x 91 mm x 77 mm)

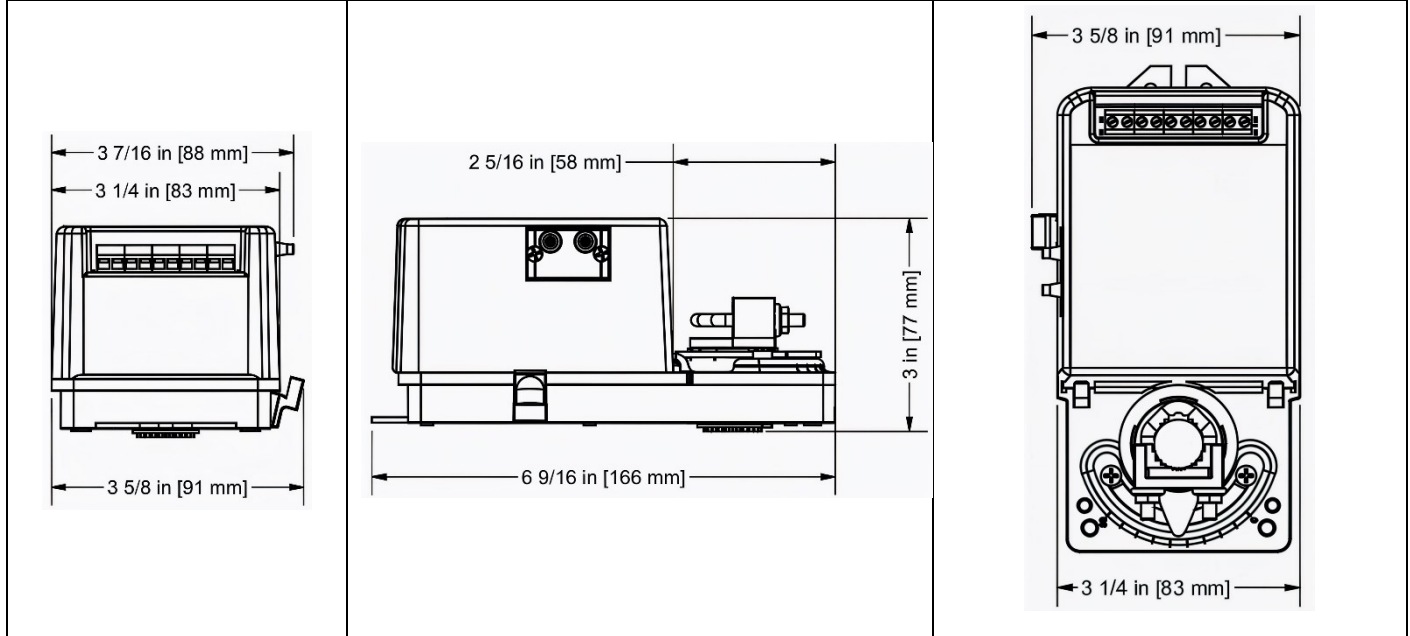

**Application Diagrams**

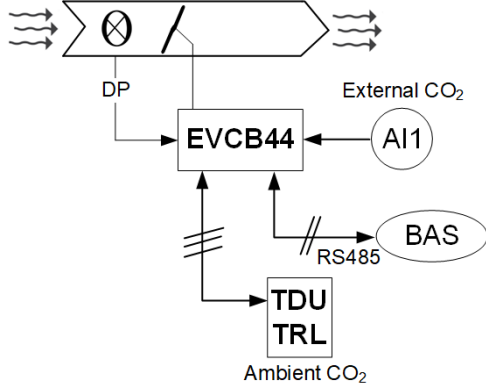
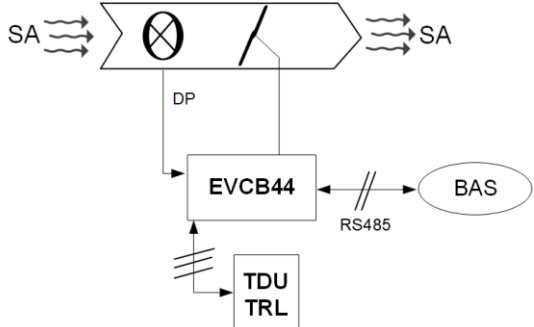
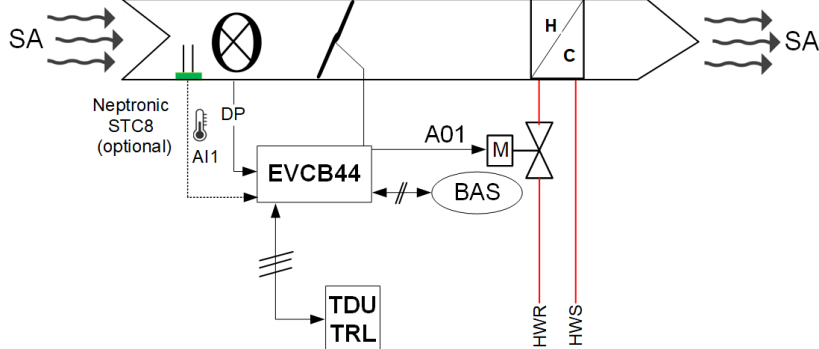
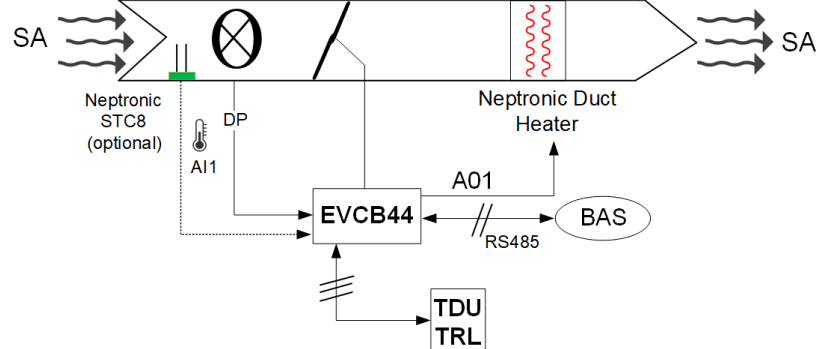
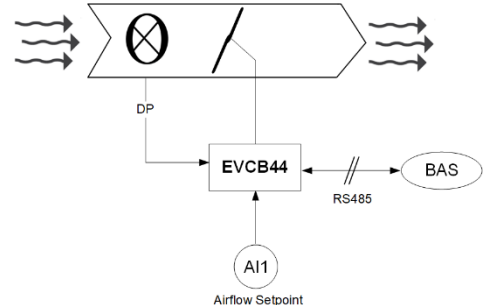
<b>Fresh Air Damper</b>	
<b>VAV Terminal Unit (Cooling Only)</b>	
<b>VAV Terminal Unit with Reheat (Hot Water)</b>	
<b>VAV Terminal Unit with Reheat (Electric)</b>	
<b>Self-Balancing Damper</b>	

### Mechanical Installation - Actuator

1. Manually close the damper blades and position the actuator to 0° or 90°.
2. Slide the actuator onto the shaft.
3. Tighten the nuts on the “U” bolt to the shaft with an 8mm wrench to a torque of 60 in-lb [6.7 Nm].
4. Slide the mounting bracket under the actuator. Ensure free movement of the slot at the base of the actuator. Place the bracket pin at mid distance of the slot.
5. Affix the bracket to the ductwork with #8 self-tapping screws.

**EVCB44N with a built-in 70 in. lb. Actuator**

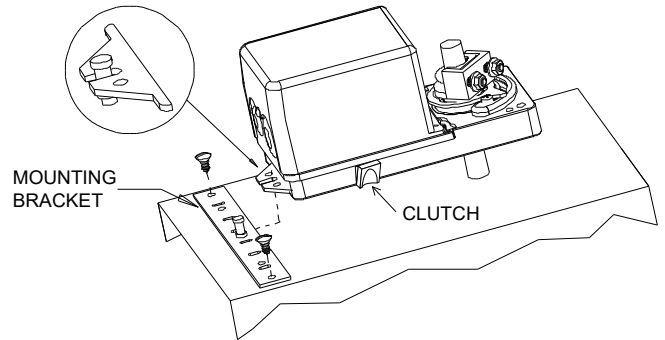

**Do not press the clutch when the actuator is powered.**



**The actuator performs an auto-stroke on power up. When changing the actuator adjustment screws, cycle power to initiate the auto-stroke.**

### Wiring

We strongly recommend that all Neptronic products be wired to a separate grounded transformer and that transformer shall service only Neptronic products. This precaution will prevent interference with, and/or possible damage to incompatible equipment.

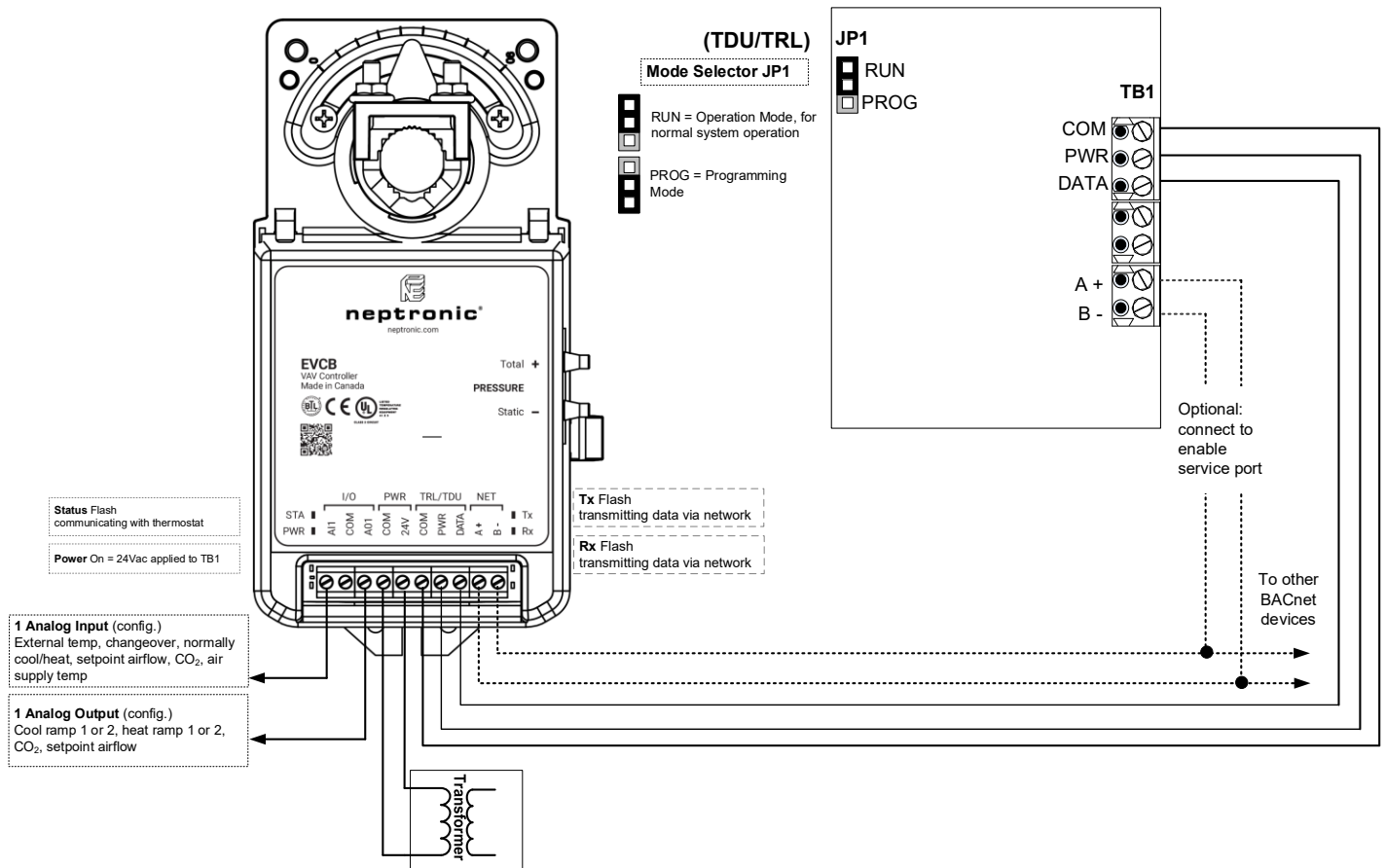



**Digital Room Sensors**

**Models**

Model #	Temp	RH	CO <sub>2</sub>	PIR	VOC
TDU00-100 TDU30-100 TDU60-100	•				
TDU00-101 TDU30-101 TDU60-101	•	•			
TDU00-102 TDU30-102 TDU60-102	•	•	•		
TDU00-103 TDU30-103 TDU60-103	•		•		
TDU00-104 TDU30-104 TDU60-104	•			•	
TDU00-105 TDU30-105 TDU60-105	•	•		•	
TDU00-106 TDU30-106 TDU60-106	•	•	•		•
TDU00-107 TDU30-107 TDU60-107	•	•	•	•	•
TDU00-108 TDU30-108 TDU60-108	•	•	•	•	



**TDU00 Series**



**TDU30 Series**



**TDU60 Series**

Model #	Temp	RH	CO <sub>2</sub>
TDU10-100 TDU40-100 TDU70-100	•		
TDU10-101 TDU40-101 TDU70-101	•	•	
TDU10-102 TDU40-102 TDU70-102	•	•	•
TDU10-103 TDU40-103 TDU70-103	•		•



**TDU10 Series**



**TDU40 Series**



**TDU70 Series**

Model #	Type	Temp	RH	CO <sub>2</sub>
TRL24	2 x 4	•		
TRLG24	2 x 4	•		•
TRLH24	2 x 4	•	•	
TRLGH24	2 x 4	•	•	•
TRL54	3 x 3	•		



**TRL24 Series**



**TRL54**

### Specifications

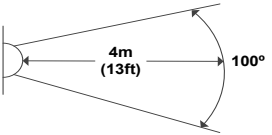
Description	TRL24, TRL54, and TDU Series
<b>Temperature Sensor (TRL24, TRL54 and TDU)</b>	
Setpoint range	10°C to 40°C [50°F to 104°F]
Control accuracy	Temperature: ±0.4°C [0.8°F]
Display resolution	±0.1°C [0.2°F]
<b>Humidity Sensor (TRLH24, TRLGH24 and TDU models with Humidity Sensors)</b>	
Sensor range	5 to 95%RH
Display resolution	0.1%
<b>CO<sub>2</sub> Sensor (TRLG24, TRLGH24 and TDU models with CO<sub>2</sub> Sensors)</b>	
Operating principle	Self-calibrating, Non-Dispersive Infrared (NDIR)
Sensor Range	0 to 2000 ppm
Setpoint range	100 to 2000 ppm
Accuracy	±30 ppm ±3% of reading
Response time	2 minutes by 90%
Display resolution	1 ppm
<b>PIR Motion Sensor (TDU00 / TDU 30 / TDU60 models with PIR Sensor)</b>	
Operating Principle	Passive Infrared (PIR)
Detection Angle	100°
Detection Distance	4m [13ft]
Detection Area	
<b>VOC Sensor (TDU00 / TDU30 / TDU60 models with VOC Sensor)</b>	
Operating Principle	Self-calibrating, Non-Dispersive Infrared (NDIR)
Sensor Range	0-1000 ppb isobutylene equivalent tVOCs
Response Time	<5 seconds for tVOC
Start up Time	15 minutes
<b>Other</b>	
Terminal Type	<b>TRL</b> models: 28~14 AWG pluggable screw terminals <b>TDU00/30/60</b> models without CO <sub>2</sub> : 22~18 AWG pluggable push-button terminals <b>TDU00/30/60</b> models with CO <sub>2</sub> : 20~14 AWG pluggable rising cage clamp screw terminals <b>TDU10/40/70</b> models: 26~14 AWG pluggable rising cage clamp screw terminals
Electrical connection	<b>Digital Room Sensor Wiring:</b> Insulated 3 core multi-strand 22 or 24 AWG cable. Maximum 50ft (15m) between controller and digital room sensor. <b>Communication Wiring:</b> Low capacitance, EIA RS-485, 22 or 24 AWG shielded twisted pair multi-strand cables (Belden 9841 or equivalent).
Network service port	Mini USB connector
Power supply	24Vac
Power consumption	1VA
Operating temperature	0°C to 50°C [32°F to 122°F]
Storage temperature	-30°C to 50°C [-22°F to 122°F]
Relative humidity	5 to 95 % noncondensing
Enclosure protection	IP 30 (EN 60529)
Weight	120 g. [0.25 lb]





**Dimensions**







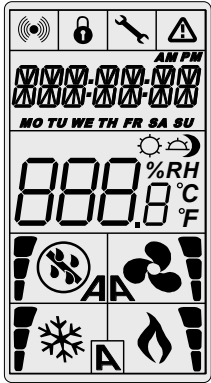

<p><b>TRL24</b></p> <p>A = 2.85"   73mm          B = 4.85"   123mm          C = 1.00"   24mm          D = 2.36"   60mm          E = 3.27"   83mm</p>	
<p><b>TRL54</b></p> <p>A = 3.00"   78mm          B = 3.00"   78mm          C = 1.00"   24mm          D = 2.36"   60mm</p>	
<p><b>TDU10 / TDU40 / TDU70 Series</b></p> <p>A = 5.24"   133mm          B = 2.87"   73mm          C = 3.74"   95mm          D = 1.22"   31mm          E = 0.75"   19mm          F = 2.00"   51mm          G = 2.18"   55mm</p>	
<p><b>TDU00 / TDU30 / TDU60 Series</b></p> <p>A = 4.88"   124mm          B = 3.25"   83mm          C = 1.75"   44mm          D = 0.96"   24mm          E = 2.07"   53mm          F = 2.36"   60mm          G = 3.28"   83mm          H = 0.78"   20mm (without CO2)          0.95"   24mm (with CO2)</p>	



### Interface







#### TRL24



	Cooling ON A: Automatic		Communication Status		Alarm status
	Heating ON A: Automatic		Menu Locked		Energy saving mode (NSB or Occupancy)
	Fan ON A: Automatic		Programming mode (Technician setting)	<b>%RH</b>	Percentage of humidity
				<b>°C or °F</b>	°C: Celsius scale °F: Fahrenheit scale







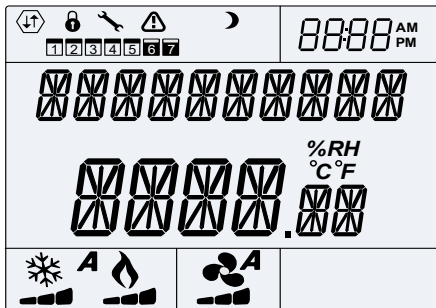

#### TRL54



	Cooling ON A: Automatic		Programming mode (Technician setting)		Alarm status
	Heating ON A: Automatic		Menu set-up Lock		Energy saving mode
<b>MIN MAX</b>	Minimum/Maximum	<b>°C or °F</b>	°C: Celsius scale °F: Fahrenheit scale		







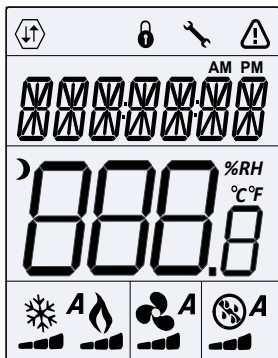

#### TDU10 / TDU40 / TDU70 Series



	Network Communication		User Lock		Programming Mode (Technician Setting)
	Alarm Status		Energy Saving Mode (NSB/OCC)	<b>1 2 3 4 5 6 7</b>	Schedule
<b>8888 AM</b>	Time	ppm	Parts Per Million	<b>°C °F %RH</b>	°C: Celsius Scale °F: Fahrenheit Scale %RH: Humidity
A	Automatic Mode		Cooling		Heating
					Fan

#### TDU00 / TDU30 / TDU60 Series



	Network Communication		User Lock		Programming Mode (Technician Setting)
	Alarm Status		Energy Saving Mode (NSB/OCC)	<b>AM PM</b>	Time
<b>°C °F %RH</b>	°C: Celsius Scale °F: Fahrenheit Scale %RH: Humidity	A	Automatic Mode		Cooling
	Heating		Fan		



### Mounting Instructions



**CAUTION:** Remove power to avoid a risk of malfunction.

- A. Remove the captive screw that's holding the base and the front cover of the unit together.
- B. Lift the front cover of the unit to separate it from the base.
- C. Pull all wires through the holes in the base.
- D. Secure the base to the wall using wall anchors and screws (supplied). Make the appropriate connections.
- E. Mount the control module on the base and secure using the screw.

#### TRL24

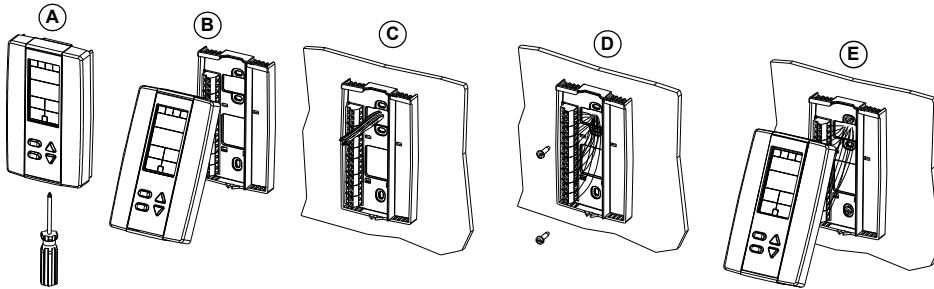

#### TRL54

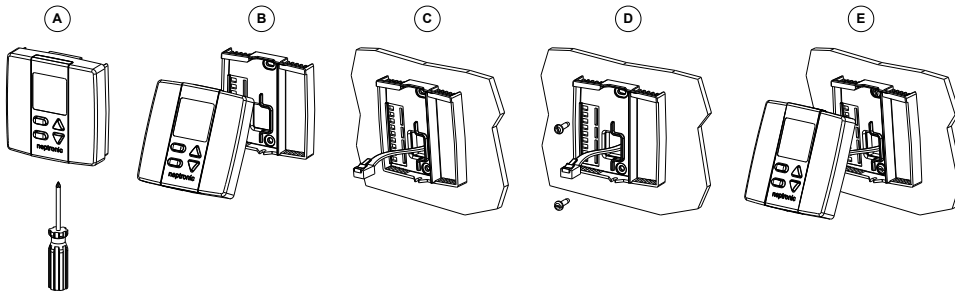

#### TDU10 / TDU40 / TDU70 Series

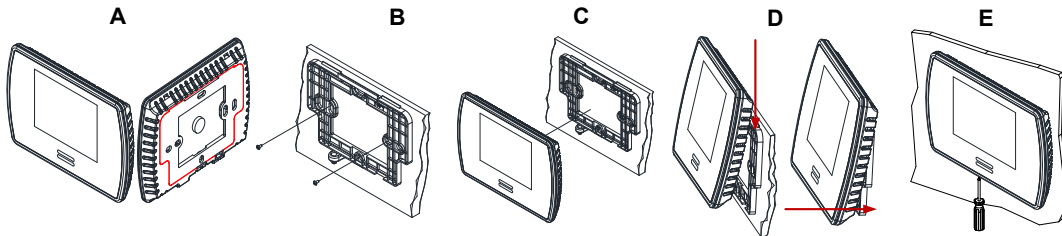

#### TDU00 / TDU30 / TDU60 Series

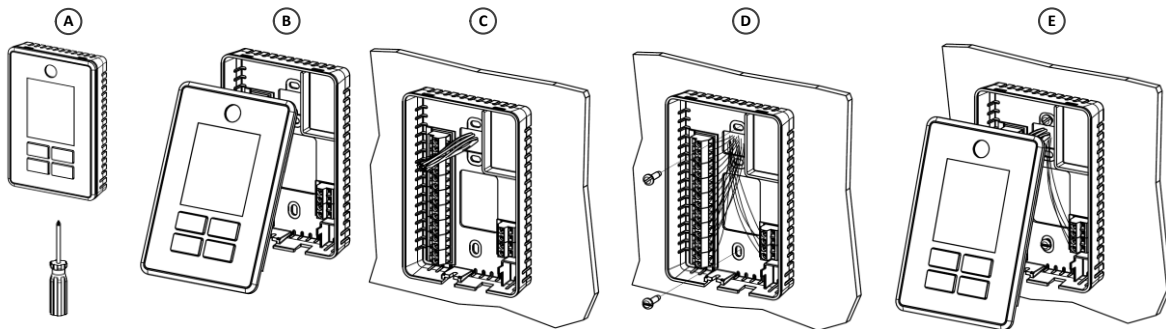

## Programming Mode Menus

### Accessing the Programming Mode

To access the programming mode, put the TDU/TRL in PROG mode. To do this:

- Remove the backplate of the TDU/TRL from its base
- Place the Mode Selector jumper (JP1) to PROG
- Replace the backplate

After making the changes to programming mode, put the TDU/TRL back in RUN mode to resume normal operation. To do this:

- Remove the backplate of the TDU/TRL from its base
- Place the Mode Selector jumper (JP1) to RUN
- Replace the backplate





*Note: If the **User Setpoint Locked** option in Temperature settings is set to **No** (TRL/TDU menus on page 13 and 16), the setpoint and control mode can be changed by the end user.*

### Navigating the Programming Menus

The menu overviews and options are the same for both TRL and TDU digital room sensors. However, the action button or the button used to access the menus and save changes is different in the digital room sensors. Use the following menu overviews with the appropriate action button as per your digital room sensor.

#### Action Buttons on Digital Room Sensor

Action Button		Task
TRL		Press to access the programming menus and save any changes.
TDU		
		Press to return to the previous step without saving.

### TRL24 and TDU – Menu (1 of 3) | Pressure, Applications, Inputs, and Outputs

For a description of the default settings for each application refer to [Annex A: Control Apps](#) on page 25.

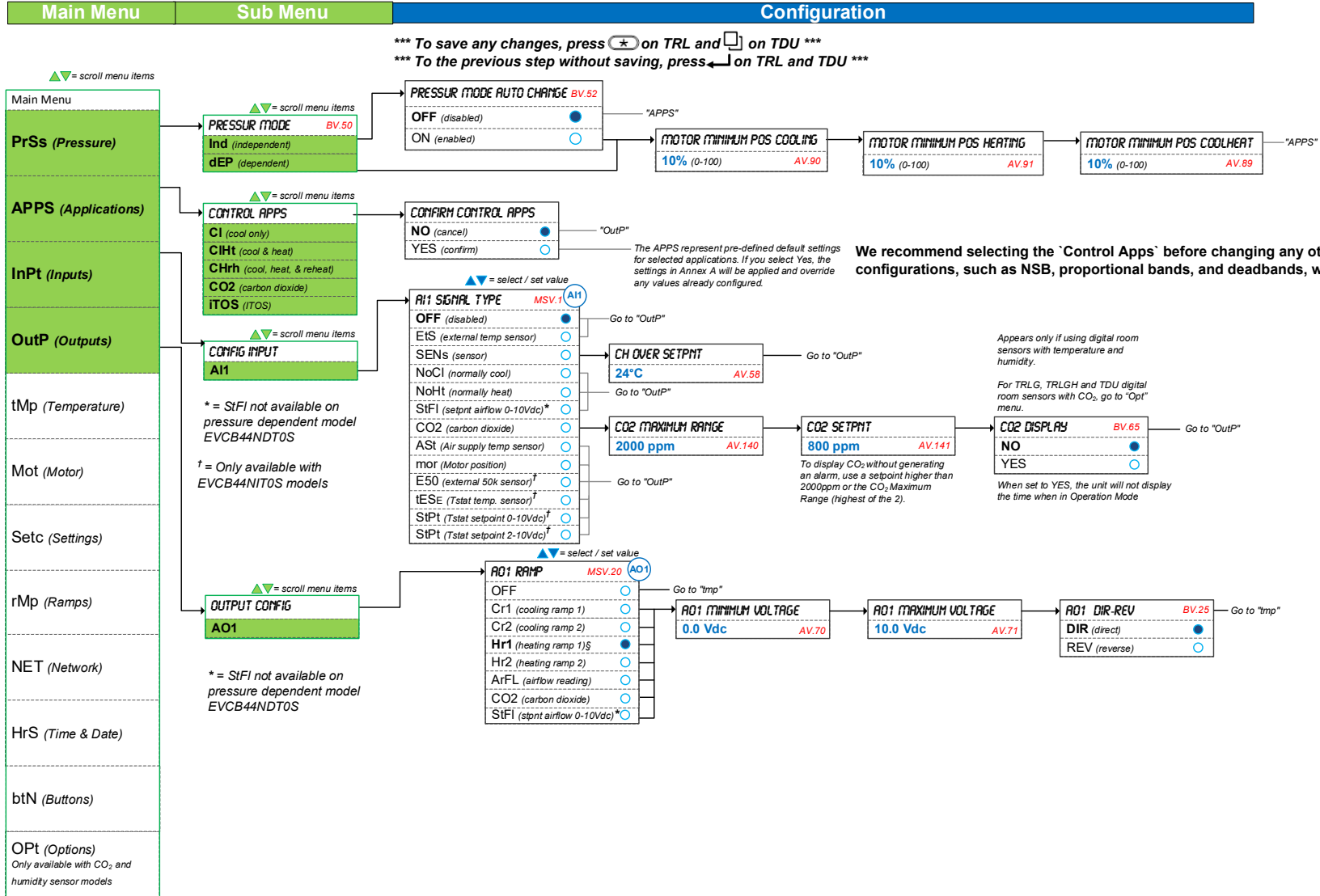

### TRL24 and TDU – Menu (2 of 3) | Temp, Motor, Settings, and Ramps

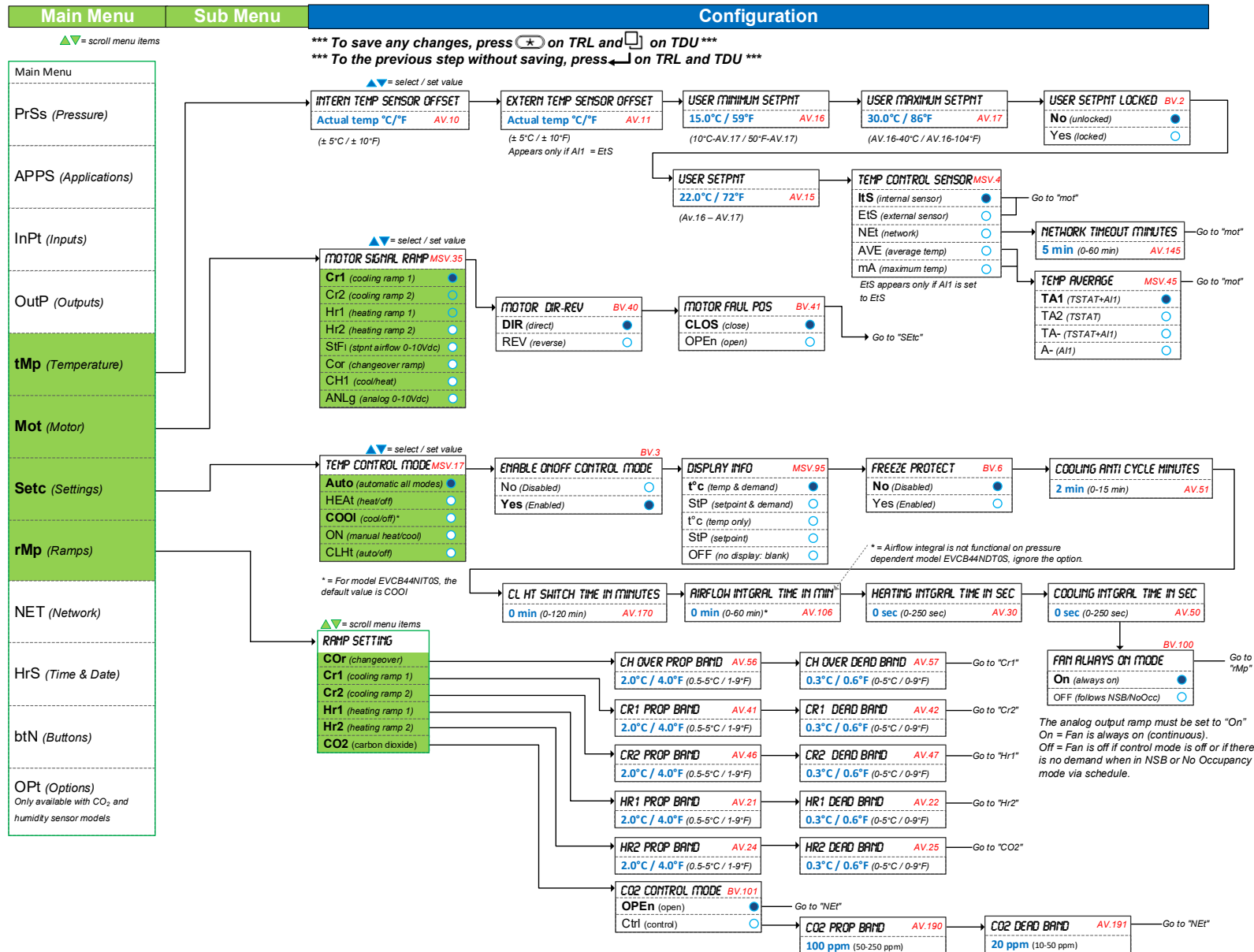

### TRL24 and TDU – Menu (3 of 3) | Network, Time, Buttons, and Options

**Main Menu** | **Sub Menu** | **Configuration**

▲▼ = scroll menu items

\*\*\* To save any changes, press **★** on TRL and **⏏** on TDU \*\*\*  
 \*\*\* To the previous step without saving, press **⏪** on TRL and TDU \*\*\*

- Main Menu
- PrSs (Pressure)
- APPS (Applications)
- InPt (Inputs)
- OutPt (Outputs)
- tMp (Temperature)
- Mot (Motor)
- Setc (Settings)
- rMp (Ramps)
- NET (Network)**
- HrS (Time & Date)
- btN (Buttons)
- OPt (Options)  
Only available with CO<sub>2</sub> and humidity sensor models

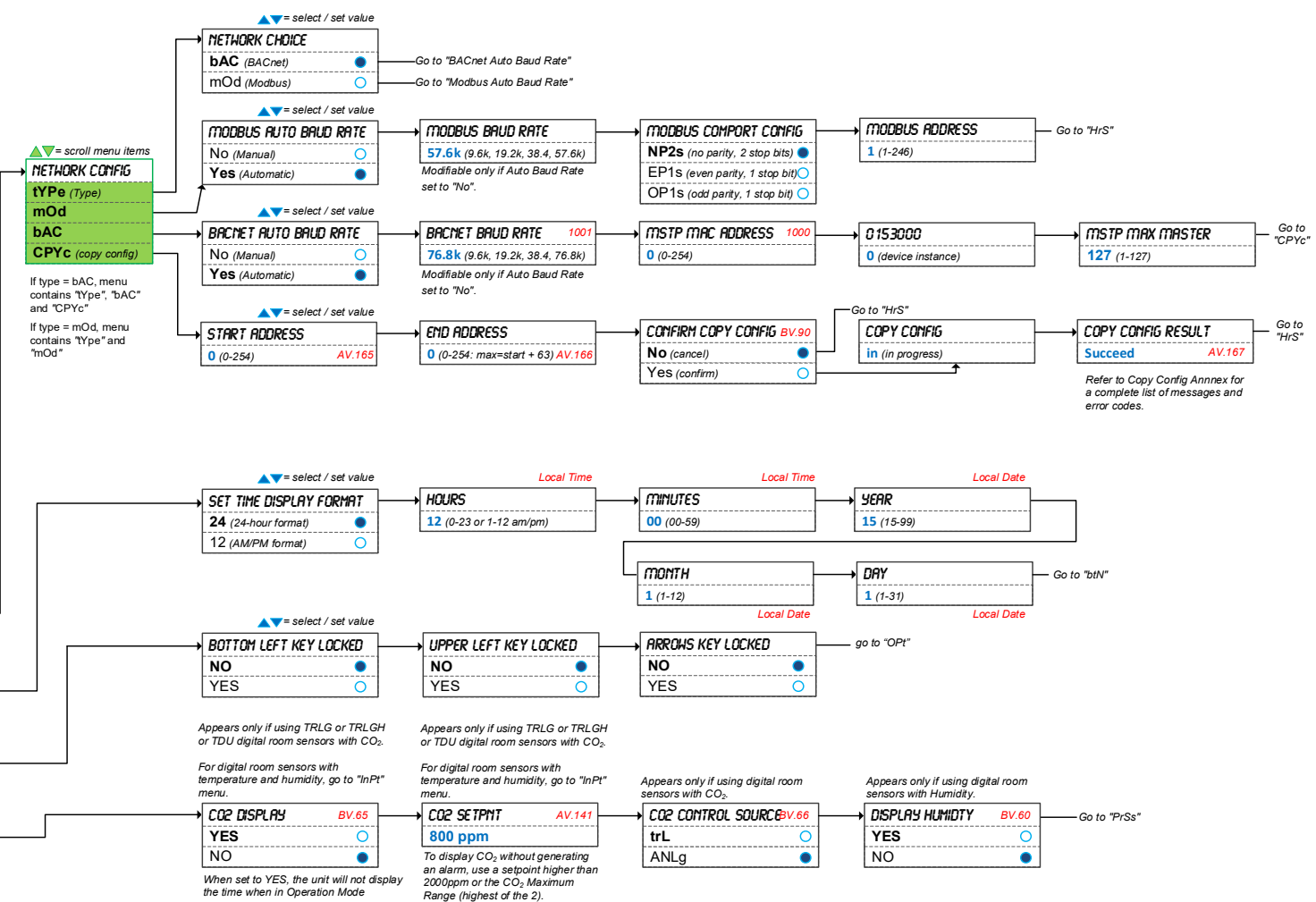



### TRL54 – Menu (1 of 3) | Pressure, Applications, Inputs and Outputs

For a description of the default settings for each application refer to [Annex A: Control Apps](#) on page 25.

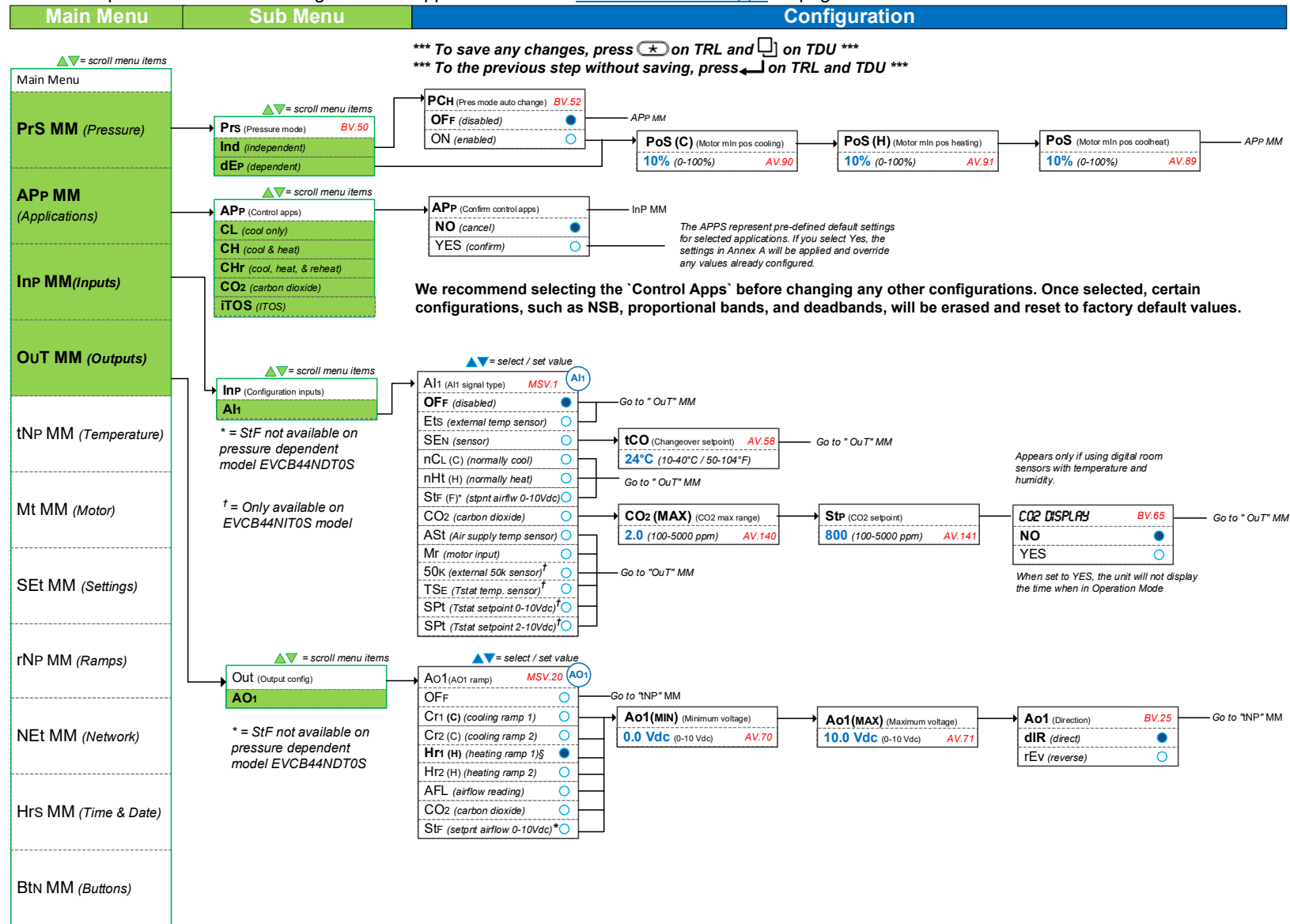



### TRL54 – Menu (2 of 3) | Temp, Motor, Settings, and Ramps

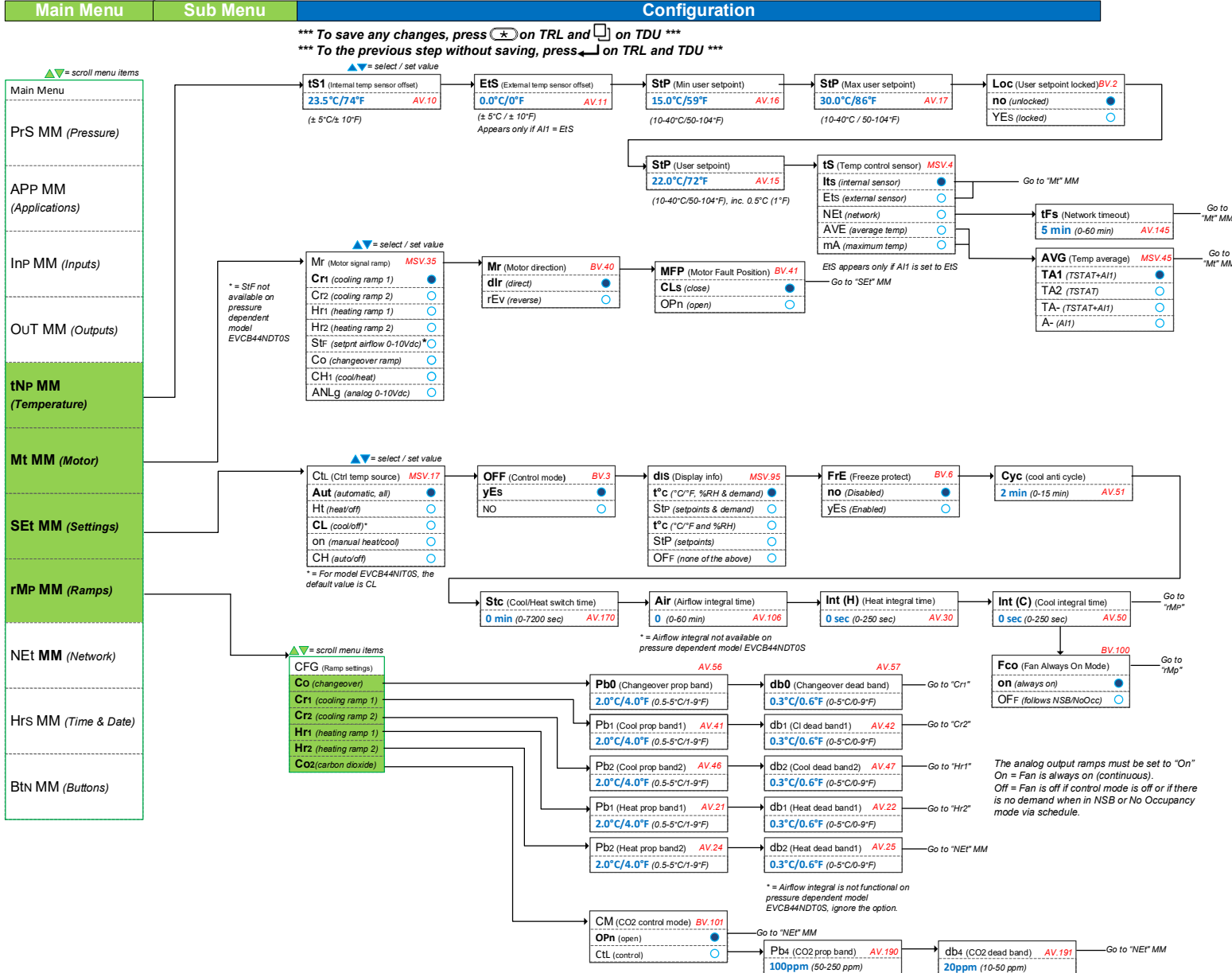

### TRL54 – Menu (3 of 3) | Network, Time, and Buttons

Main Menu	Sub Menu	Configuration
-----------	----------	---------------

\*\*\* To save any changes, press **\*** on TRL and **□** on TDU \*\*\*  
 \*\*\* To the previous step without saving, press **←** on TRL and TDU \*\*\*

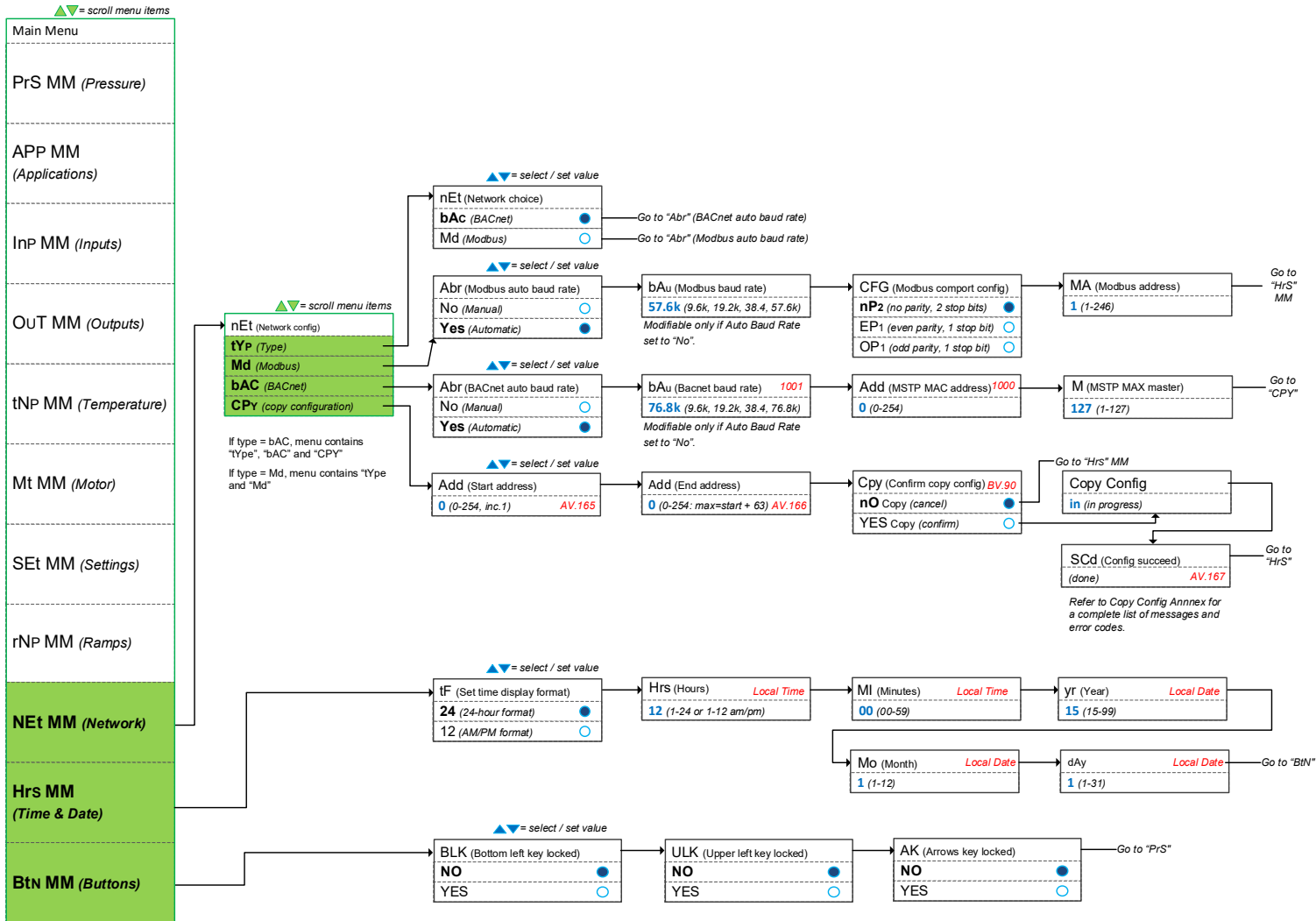



## Operation Mode Menus

This menu is accessible through normal operation mode. The Mode Selector jumper (JP1) of the digital room sensor must be set to the "RUN" position (Operation Mode). Refer to Wiring on page 5.



*Note Since the action buttons are different on TRL and TDU digital room sensor series, both buttons have been included in the instructions. Refer to the Action Buttons on Digital Room Sensor section to know and use the button as available on your digital room sensor.*

1. Press the [] / [] and [] buttons simultaneously for 5 seconds. The "Enter Password" screen appears.
2. Enter the password within 1 minute by using the arrow keys to increase or decrease the value and the [] / [] and [] buttons to toggle between the digits.
  - a. Password **372** = Temperature Offset Menu
  - b. Password **637** = Network Settings Menu
  - c. Password **757** = Airflow Balance Mode
3. If you enter the wrong password, the digital room sensor displays "Error" and returns to Operation Mode. The digital room sensor will return to normal mode if you navigate through the entire menu and do not make any selection, or if you do not press any key for 5 minutes. The changed values will be saved automatically.

### Menu 372 – Temperature Offset – TRL24/TDU and TRL54

1. "INTERN TEMP SENSOR OFFSET" | "TS1" (temperature sensor offset)



Range:	10 to 40°C	[50 to 104°F]
Offset:	Max ± 5°C	
Increment:	0.1°C	[0.2°F]

Compare the displayed temperature reading with a known value from a digital room sensor. To offset or calibrate the sensor, use the arrows key to set the desired temperature reading. This is useful for digital room sensors installed in areas where the temperature read is slightly different than the room's actual temperature. For example, a digital room sensor placed right under the air diffuser.

If the digital room sensor is set to use an external temperature sensor (EtS), the digital room sensor displays "OFF".

2. "EXTERN TEMPER SENSOR OFFSET" | "ETS" (external temperature sensor offset)



Range:	0 to 50°C	[41 to 122°F]
Offset:	Max ± 5°C	
Increment:	0.1°C	[0.2°F]

This option appears if you've set one of the analog inputs to **EtS** (External temperature sensor). When the digital room sensor is connected to the appropriate analog input, the display shows the temperature read by the external temperature sensor. Adjust the offset by comparing it with a known value (e.g. thermometer). If the sensor is not connected or short circuited, then the unit displays the sensor's limit.

3. "INPUT3 READING" | "PRS" (input 3 reading)



Range:	250mV (0") to 4000mV (1")
--------	---------------------------

Displays the voltage output value in mV of the pressure sensor. Does not appear for EVCB44NDT0S (pressure dependent) model.



### Menu 637 – Network Settings - TRL24 and TDU

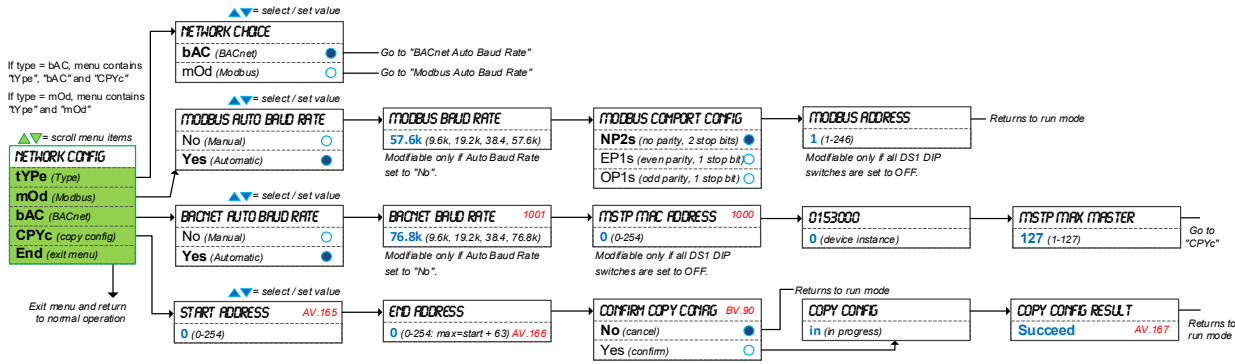

\*\*\* To save any changes, press **\*** on TRL and **□** on TDU \*\*\*  
 \*\*\* To the previous step without saving, press **←** on TRL and TDU \*\*\*

### Menu 757 – Airflow Balance Mode - TRL24 and TDU

Pressure Independent: model EVCB44NIT0S

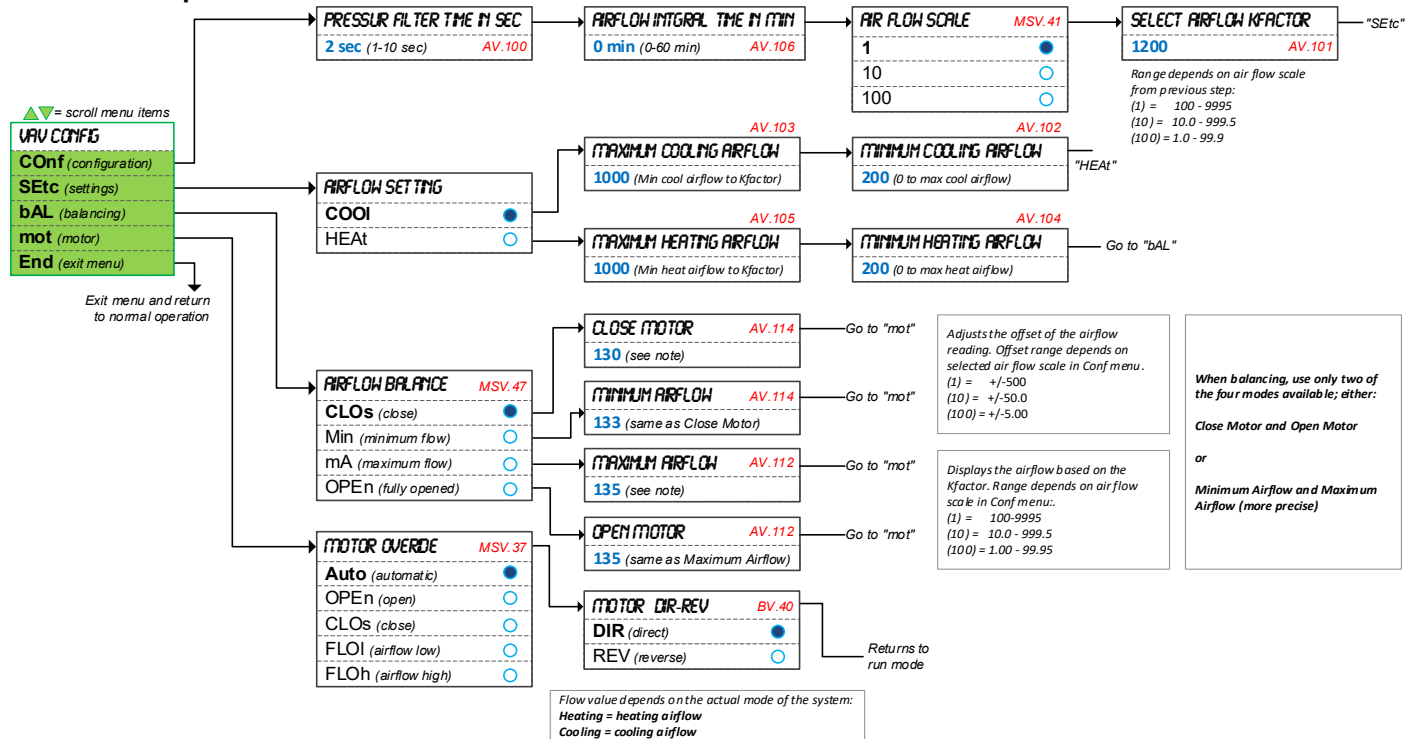

\*\*\* To save any changes, press **\*** on TRL and **□** on TDU \*\*\*  
 \*\*\* To the previous step without saving, press **←** on TRL and TDU \*\*\*



Note: Refer to [EVCB-Airflow Balance Instructions](#) on Neptronic website for further information on airflow balancing function.

Pressure dependent model EVCB44NDT0S or other models if in pressure dependent mode

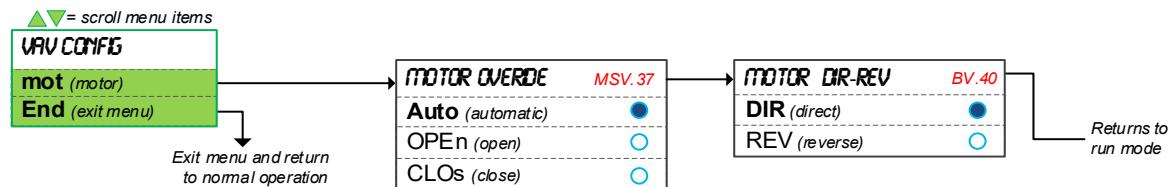

\*\*\* To save any changes, press **\*** on TRL and **□** on TDU \*\*\*  
 \*\*\* To the previous step without saving, press **←** on TRL and TDU \*\*\*



### Menu 637 – Network Settings - TRL54

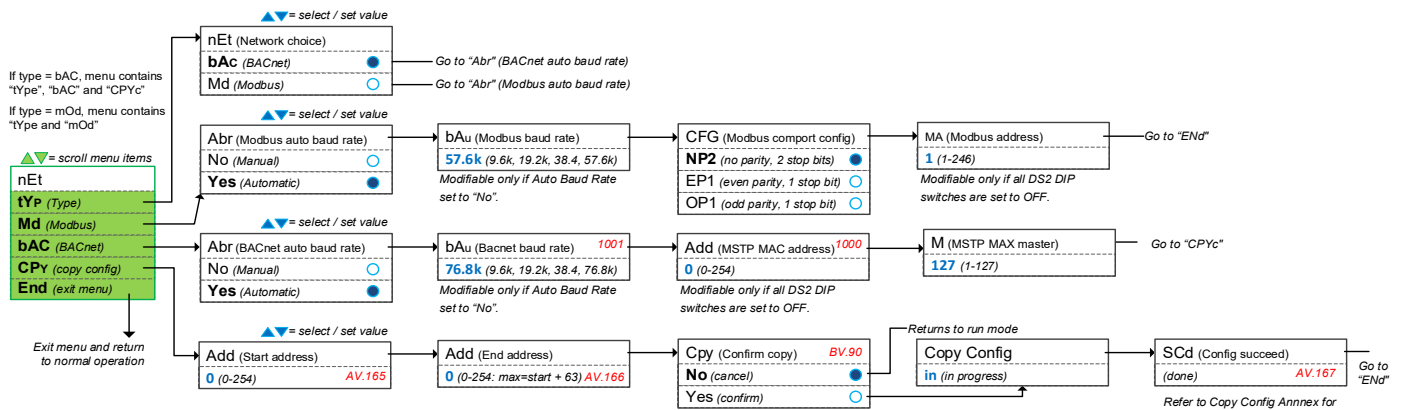

\*\*\* To save any changes, press **★** on TRL and **□** on TDU \*\*\*  
 \*\*\* To the previous step without saving, press **←** on TRL and TDU \*\*\*

### Menu 757 – Airflow Balance Mode - TRL54

#### Pressure Independent: model EVCB44NIT0S

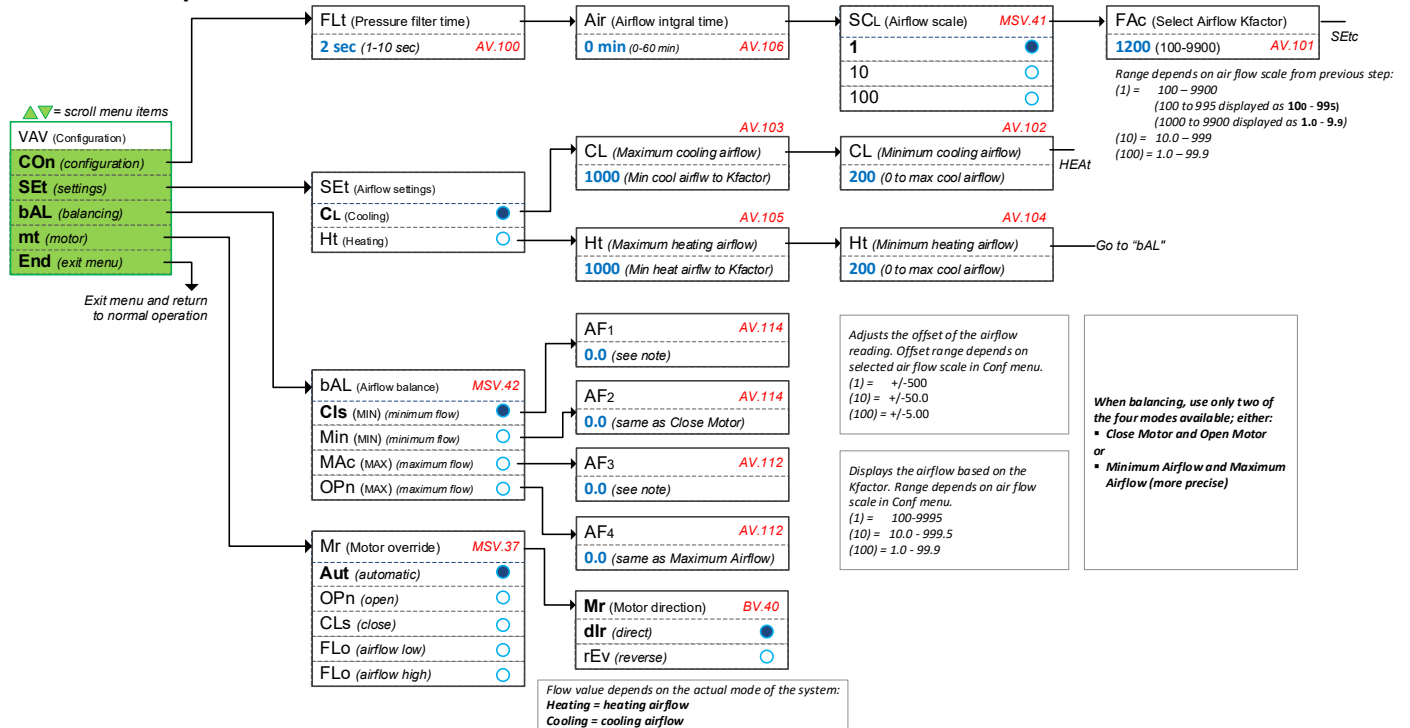

\*\*\* To save any changes, press **★** on TRL and **□** on TDU \*\*\*  
 \*\*\* To the previous step without saving, press **←** on TRL and TDU \*\*\*



Note: Refer to [EVCB-Airflow Balance Instructions](#) on Neptronic website for further information on the airflow balancing function.

#### Pressure dependent model EVCB44NDT0S or other models if in pressure dependent mode

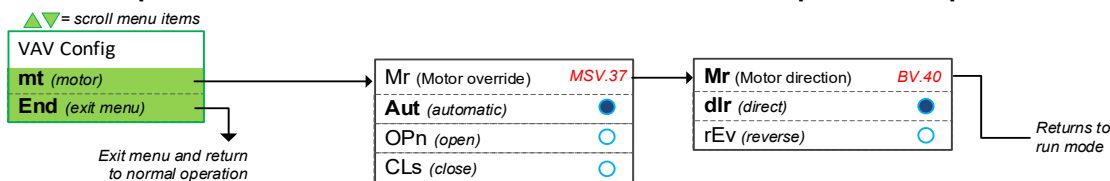







\*\*\* To save any changes, press **★** on TRL and **□** on TDU \*\*\*  
 \*\*\* To the previous step without saving, press **←** on TRL and TDU \*\*\*



## Reset to Factory Default Settings



This will erase all actual configurations and replace them with the factory default settings.

1. The Mode Selector jumper (JP1) of the digital room sensor must be set to the "RUN" position (Operation Mode). Refer to Wiring on page 5.
2. During the power up sequence of the controller and digital room sensor, press and hold both the  and  buttons.
3. The "Enter Password" screen appears. Enter **372** within 1 minute by using the arrow keys to increase or decrease the value and the [ / ] and  buttons to toggle between the digits.
4. Use the arrow buttons to select YES and then press [ / ].



## Operation Mode

The Mode Selector Jumper (JP1) of the digital room sensor must be set to the "RUN" position (Operation Mode). Refer to [Wiring](#) on page 5.

## TRL24 - Runtime User Interface

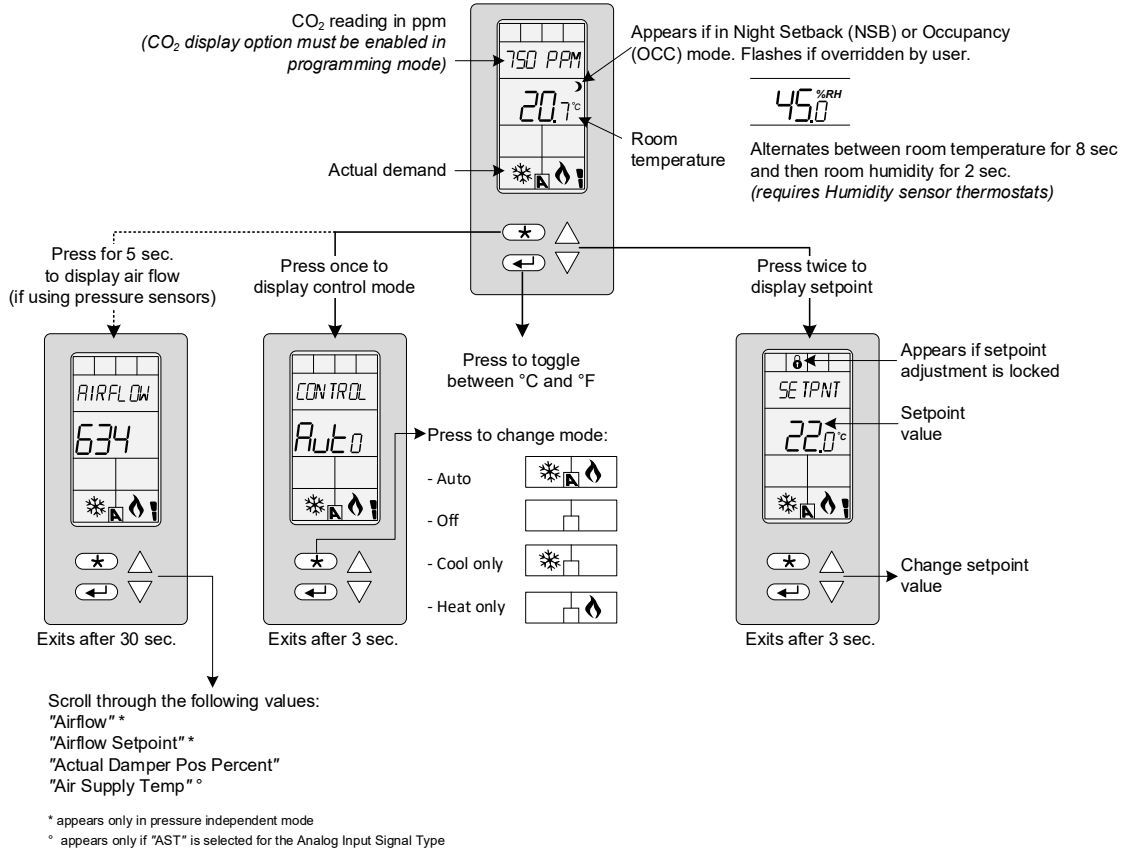

## TRL54 - Runtime User Interface

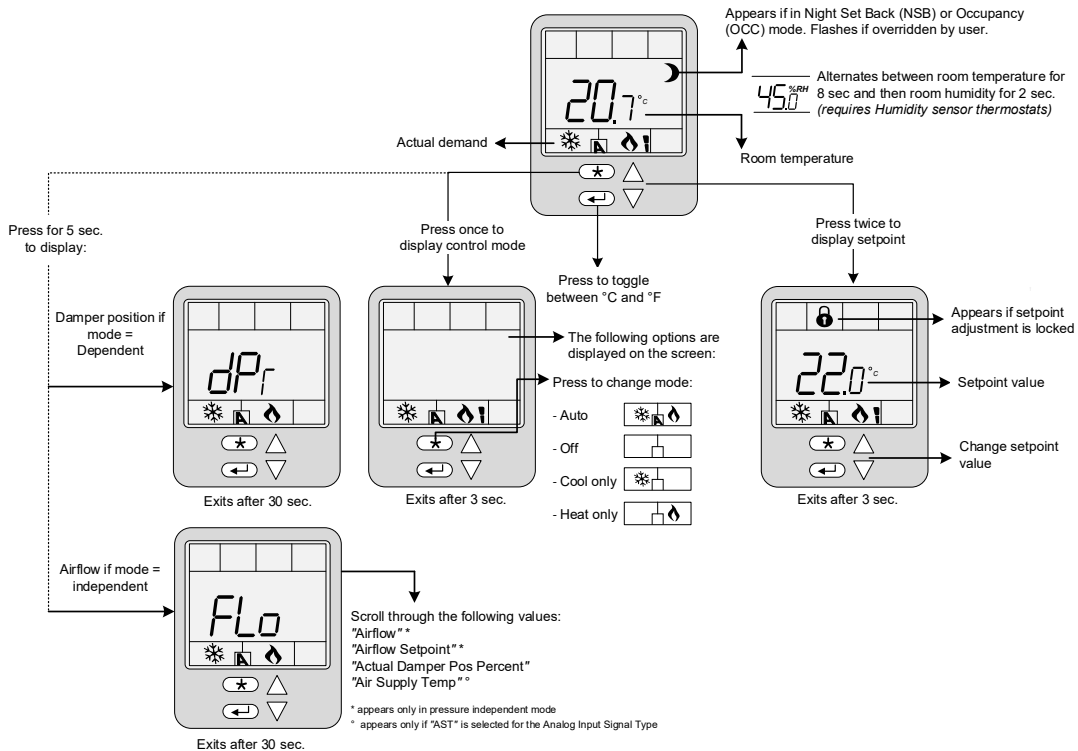





TDU10 / TDU40 / TDU70 Series – Runtime User Interface

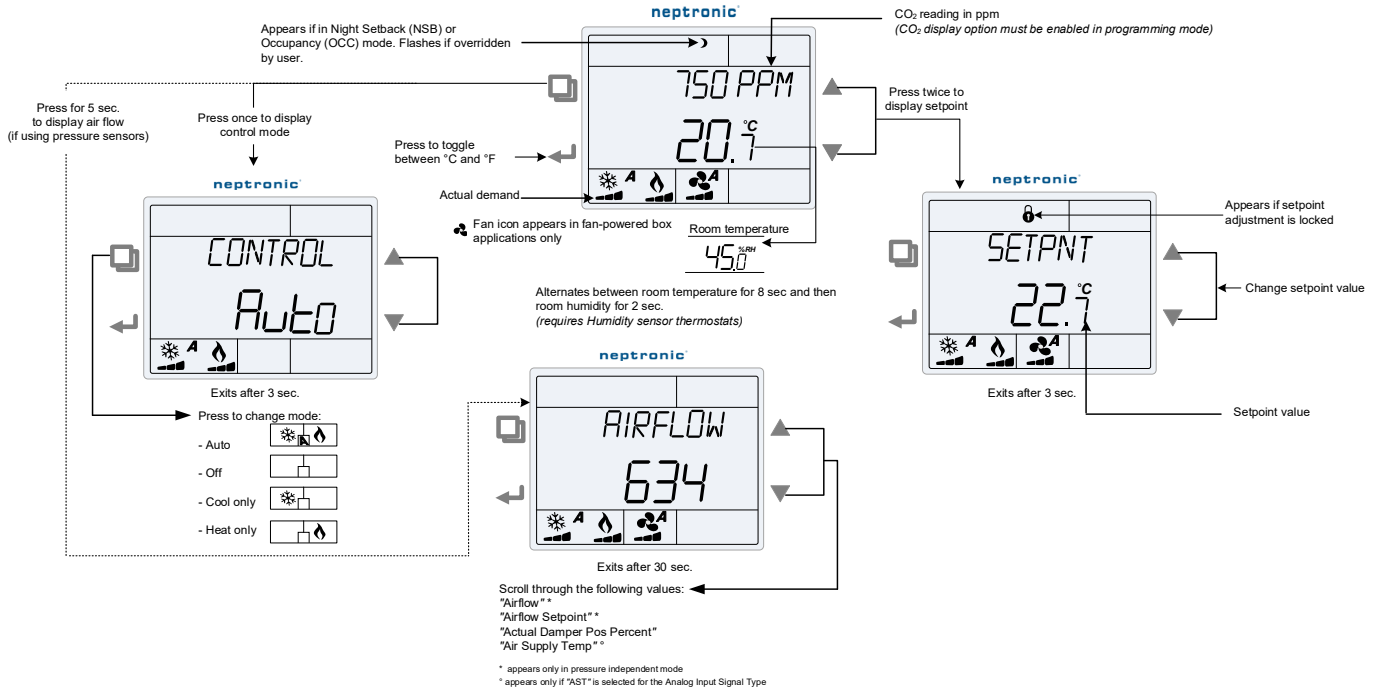

TDU00 / TDU30 / TDU60 Series – Runtime User Interface

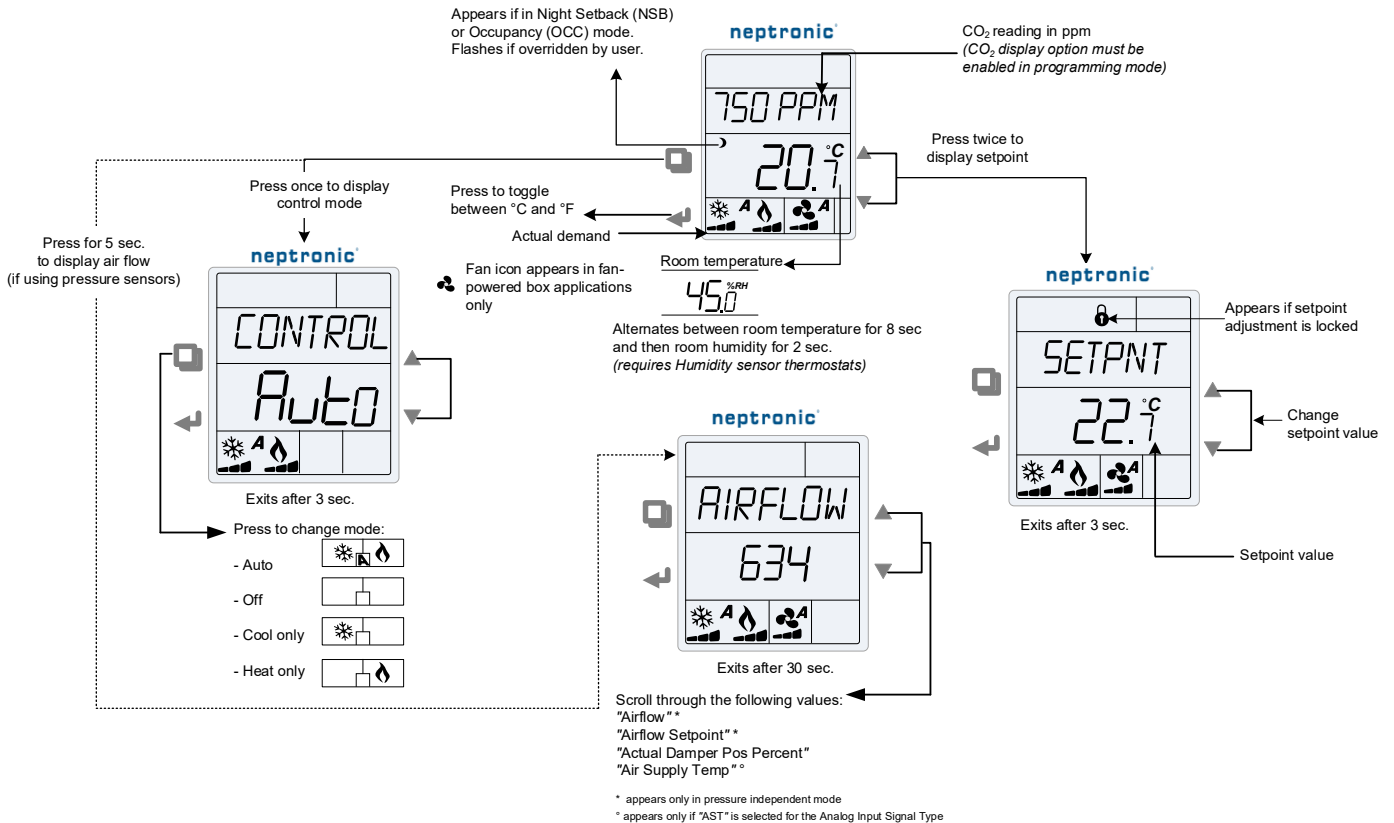



## Operation Mode Settings

### Power Up

Upon power up, the LCD illuminates and all segments appear for 2 seconds. The digital room sensor then displays its current version of the digital room sensor for 2 seconds followed by the current version of the controller for 2 seconds. Pressing any key on the digital room sensor illuminates the LCD for 4 seconds.

### CO<sub>2</sub> (Digital Room Sensors with CO<sub>2</sub>)

If enabled via the configuration menu, the digital room sensor displays the CO<sub>2</sub> reading on the first line above the temperature reading. If CO<sub>2</sub> display is enabled, the time will not be displayed.

### Select Temperature Scale

To toggle the temperature scale between °C and °F, press the button.

### Temperature Display and Setpoint

If enabled in the "Display Info" menu of the *Temp, Motor, Settings, and Ramps of TRL24 or TRL54 on pages 13 or 16*, the digital room sensor displays the temperature reading for 8 seconds.

If the sensor is disconnected or short circuited, then the unit displays the sensor's limit.

To display the setpoint, press the or key twice. The setpoint appears for 3 seconds.

To adjust the setpoint, press the arrow keys while the temperature is displayed. If the setpoint adjustment has been locked "Setpnt Locked" option in **Temperature settings** (TRL/TDU menus on page 13 and 16), the lock symbol appears.

### Humidity Display

If enabled in the "Options" menu of the *Network, Time, Buttons, and Options* of TRL24 on page 14, the digital room sensor displays the temperature reading for 8 seconds and then displays the humidity reading for 2 seconds.

If the sensor is disconnected or short circuited, then the unit displays the sensor's limit.

### Airflow and Air Supply Temperature

Press and hold the [ / ] button for 5 seconds and use the arrow keys to view the "airflow", "airflow Setpnt", "actual damper pos percent" and "air Supply Temp". After 30 seconds without any action, the digital room sensor returns to operation mode. The air supply temperature appears only if analog input AI1 is configured with the AST option. Not available on the following pressure dependent model *EVCB44NDT0S*.

### Control Mode

To access the Control Mode, press the [ / ] button. The Control Mode appears for 3 seconds.

Press the [ / ] button to scroll through the following control modes. These options can vary depending on the options selected in "Temp Control Mode" and "Enable OnOff Control Mode".

- Auto (Automatic Cooling or Heating)
- OFF (if it is not disabled in Programming Mode)
- Cooling only (on, with cooling symbol)
- Heating only (on, with heating symbol)

### Night Setback (NSB) or Occupancy Mode

In the **nSb** (Night setback contact) or **Occ** (occupancy mode), the digital room sensor enters NSB or No Occupancy Mode (the symbol appears) and uses the NSB or OCC heating and cooling setpoints.

If not locked, you can override the night setback or no occupancy mode for a predetermined period by pressing any of the 4 buttons. During the override period the symbol will flash. If the symbol does not flash, the override period is finished, or the night setback or no occupancy override has been locked in programming mode.

### Set Time and Date

1. Ensure that JP1 on the digital room sensor is set to run.
2. Press and hold the button for 5 seconds
3. Use the arrow keys to set the desired value. Press the [ / ] button to save and go to the next step. Press the button to go to the previous step without saving.

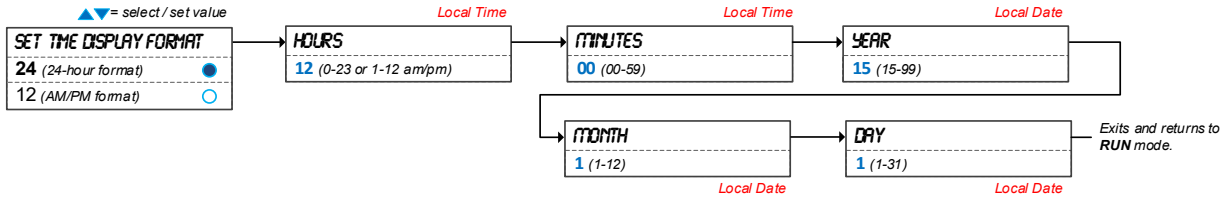

\*\*\* To save any changes, press **\*** on TRL and **]** on TDU \*\*\*

\*\*\* To the previous step without saving, press **←** on TRL and TDU \*\*\*



Note Time will only be displayed on the TDU when the BACnet scheduler is active. To achieve this, set the proper BACnet Object present value to Yes (1): **EVCB BV.70 – Cfg\_ActiveSchedule**.

## Annex A: Control Apps

Refer to *Pressure, Applications, Inputs, and Outputs* menus of TRL24 or TRL54 on pages 12 and 15 for more information. The available **Control Apps** vary according to the model.

Description	CL (cool only)	CLHt (cool/heat)	CHrH (cool/heat/reheat)	CO <sub>2</sub> (CO <sub>2</sub> )	ITOS (ITOS)
Min. Setpoint	20°C (68°F)	20°C (68°F)	20°C (68°F)	20°C (68°F)	15°C (59°F)
Max. Setpoint	28°C (82°F)	28°C (82°F)	28°C (82°F)	28°C (82°F)	30°C (86°F)
Changeover Setpt	24°C (75°F)	20°C (68°F)	20°C (68°F)	20°C (68°F)	24°C (75°F)
Motor Ramp	CR1	CO <sub>r</sub>	CO <sub>r</sub>	CO <sub>r</sub>	CR1
AO1 ramp	HR1	CR1	HR1	CR1	HR1
AI1 Input	OFF	SENS	SENS	SENS	OFF
Heat Prop Band 2	2°C (4°F)	2°C (4°F)	2°C (4°F)	2°C (4°F)	2°C (4°F)
Heat Deadband 2	1.3°C (2.6°F)	1.3°C (2.6°F)	1.3°C (2.6°F)	1.3°C (2.6°F)	0.3°C (0.6°F)
Cool Deadband 2	1.3°C (2.6°F)	1.3°C (2.6°F)	1.3°C (2.6°F)	1.3°C (2.6°F)	0.3°C (0.6°F)

## Legend

Grey Text = Standard default value

**Bold Text** = Special default value for selected application

- HR = Heating ramp
- CR = Cooling ramp
- CO<sub>r</sub> = Changeover ramp
- SENS = Changeover temperature sensor
- nSb.o = Night Setback (normally open)
- Occ.o = Occupancy mode (normally open)

- AO = Analog output
- AI = Analog input



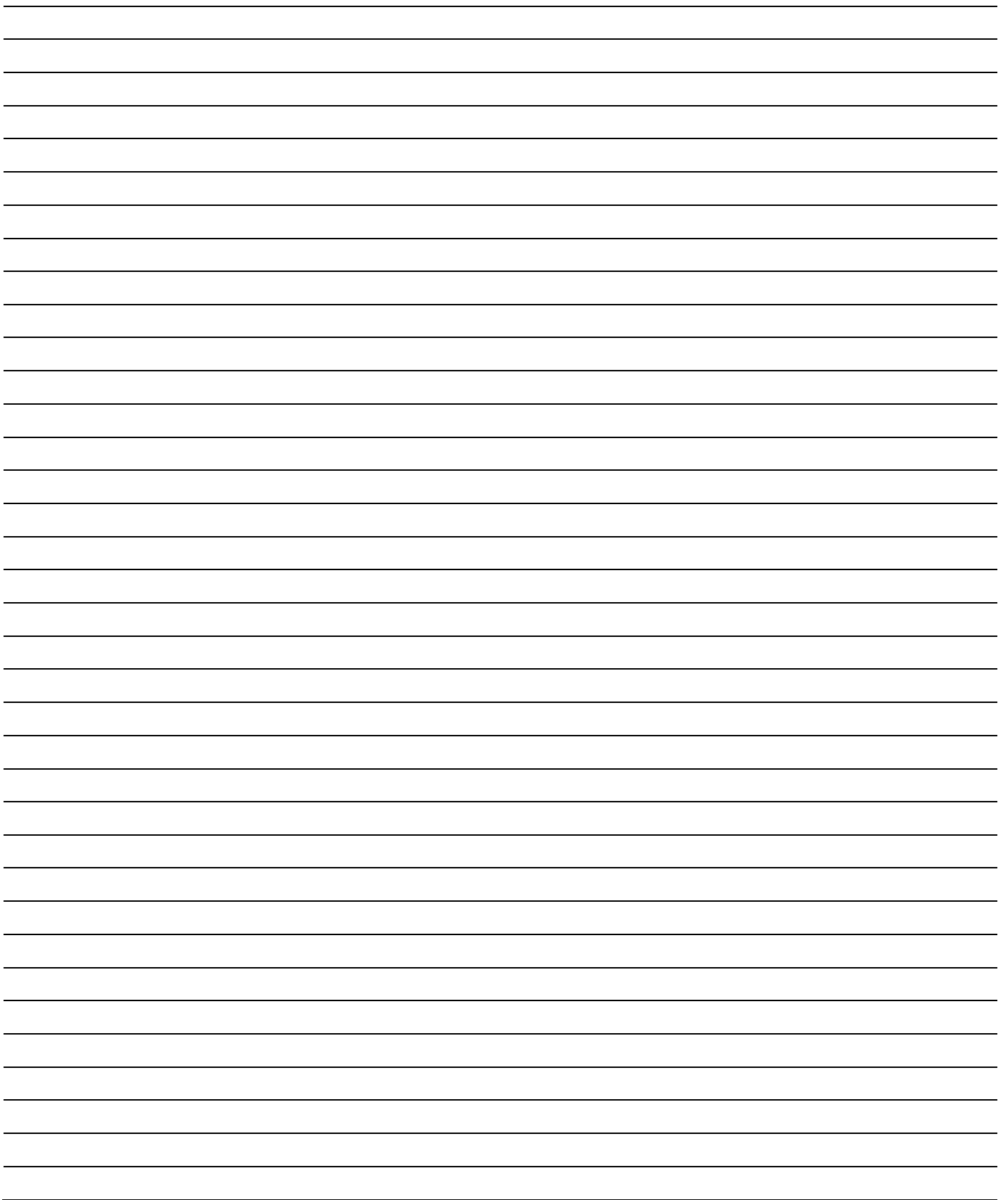



Recycling at end of life: please return this product to your Neptronic local distributor for recycling. If you need to find the nearest Neptronic authorized distributor, please consult [www.neptronic.com](http://www.neptronic.com).



**neptronic®**

400 Lebeau blvd, Montreal, Qc, H4N 1R6, Canada

[www.neptronic.com](http://www.neptronic.com)

Toll free in North America: 1-800-361-2308

Tel.: (514) 333-1433

Fax: (514) 333-3163

Customer service fax: (514) 333-1091

Monday to Friday: 8:00am to 5:00pm (Eastern time)