



**Models**

- EVCB14NIT0S** (0 TRIACS / pressure independent)
- EVCB14NIT2S** (2 TRIACS / pressure independent)
- EVCB14NIT4S** (4 TRIACS / pressure independent)
- EVCB14NIT4X\*** (4 TRIACS / independent / external motor)
- EVCB14NDT4X\*** (4 TRIACS / dependent / external motor)
- EVCB14NDT4S** (4 TRIACS / pressure dependent)
- EVCB14NIT0SF** (0 TRIACS / independent / feedback)
- EVCB14NIT4SF** (4 TRIACS / independent / feedback)

\* For use with either floating or modulating actuators

**TRL Series Digital Room Sensor**

**TRL54** (With temperature sensor)

**TDU Series Digital Room Sensor**

- TDU00** (Vertical Grey LCD, white enclosure)
- TDU30** (Vertical Black LCD, black enclosure)
- TDU60** (Vertical Black LCD, white enclosure)

- TDU10** (Horizontal Grey LCD, white enclosure)
- TDU40** (Horizontal Black LCD, black enclosure)
- TDU70** (Horizontal Black LCD, white enclosure)

**Description**

The EVCB Series is a combination controller and digital room sensor with support for networked communications via the BACnet MS/TP or Modbus protocol. The Networkable VAV Controller is designed for simple and accurate control of any variable air volume box in a number of zone control configurations. Its field configurable algorithms enable versatile implementation of required control sequences.

**Features**

- Field configured VAV algorithms, inputs and outputs
- Built-in actuator, 70 lb-in. (select models, not available on EVCB14NIT4X and EVCB14NDT4X)
- Control external actuators using analog (0-10Vdc, adjustable) or floating signals with feedback (models EVCB14NIT4X and EVCB14NDT4X)
- On board differential pressure sensor (select models)
- Simple air balancing and commissioning via digital room sensor
- Automatically sets operation mode to pressure dependent or independent based on the presence of air flow
- Select direction on analog outputs
- Configurable PI (Proportional-Integral) function
- Independent, configurable proportional control band and dead band per ramp
- Selectable internal or external temperature sensor (10KΩ)
- External CO2 sensor input with integrated logic
- Changeover by contact or external temperature sensor
- Internal and external temperature sensor calibration
- Optional potentiometer feedback for increased precision of actuator position
- Freeze protection
- Removable, raising clamp, non-strip terminals

**Operational Features**

- Backlit LCD with simple icon and text driven menus
- Select digital room sensor's default display
- Network service port via on-board mini USB connector
- Manual night set back or no occupancy override
- Multi level lockable access menu and setpoint
- Selectable Fahrenheit or Celsius scale
- 3-wire connection to controller and 4 push buttons

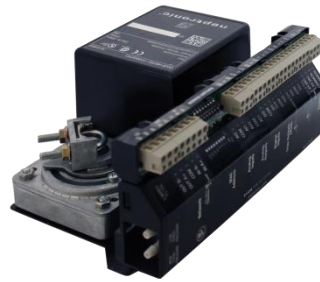

EVCB Series



TRL54



TDU00 / TDU30 / TDU60 Series



TDU10 / TDU40 / TDU70 Series

**Applications**

- Single duct, cooling only
- Single duct cooling and/or heating
- Up to 4 stage reheat and/or cool
- Up to 4 On/Off heat and/or cool
- Up to 4 time proportioned (TPM) heat or reheat
- Up to 2 analog (0-10Vdc) reheat and/or cool
- Up to 2 floating heat and/or cool
- Pressure dependent or pressure independent
- With or without auto changeover
- Supply/exhaust (requires an additional EVC)

**Typical Application**

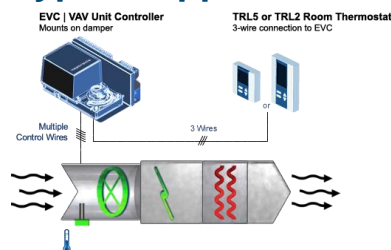

**Network Communication**

- BACnet MS/TP or Modbus communication port
- Select MAC address via DIP switch or via network
- Automatic baud rate detection

**BACnet MS/TP®**

- Automatic device instance configuration
- Copy & broadcast configuration via digital room sensor menu or via BACnet to other controllers
- BACnet scheduler
- Firmware upgradeable via BACnet
- Support for COV (change of value)

**Modbus**

- Modbus @ 9600, 19200, 38400 or 57600 bps
- RTU Slave, 8 bits (configurable parity and stop bits)
- Connects to any Modbus master



### Controller Specifications

Description	EVCB Series
Torque	70 in.lb. [8 Nm] at rated voltage
Power consumption	10 VA max
Running time through 90°	90 seconds
Power supply	22 to 26 Vac 50/60 Hz
Inputs	2 Universal inputs (Thermistor 10KΩ Type 3, digital 24Vac/dry contact, or 0-10Vdc) 2 digital inputs
Outputs	2 analog outputs (0-10 Vdc or 2-10Vdc; selectable) Up to 4 TRIAC outputs 24 Vac, 500mA max thermal fuse in series with each TRIAC output (on/off, pulse, or 2 floating outputs)
Real Time Clock	Real-time clock (RTC) with super capacitor backup (approximately 3 days)
BACnet	BACnet® MS/TP @ 9600, 19200, 38400 or 76800 bps (BAS-C)
Modbus	Modbus RTU slave @ 9600, 19200, 38400 or 57600. Selectable parity and stop bit configuration: No parity, 2 stop bit Even parity, 1 stop bit Odd parity, 1 stop bit
Communication connection	Low capacitance, EIA RS-485, 22 or 24 AWG shielded twisted pair multi-strand cables (Belden 9841 or equivalent).
Digital room sensor connection	Insulated 3 core multi-strand 22 or 24 AWG cable. Maximum 50ft (15m) between controller and digital room sensor.
Electrical connection	Insulated 2 core 0.8 mm <sup>2</sup> [18 AWG] minimum power cable.
Operating temperature	0°C to 50°C [32°F to 122°F]
Storage temperature	-30°C to 50°C [-22°F to 122°F]
Relative Humidity	5 to 95% non condensing
Weight	1.26 kg. [2.8 lb]



**The actuator performs an auto-stroke on power up. When changing the actuator adjustment screws, cycle power to initiate the auto-stroke. Auto-stroke is not available on EVC pressure independent without feedback.**

### Dimensions

**EVC with a built-in 70 in. lb. Actuator**

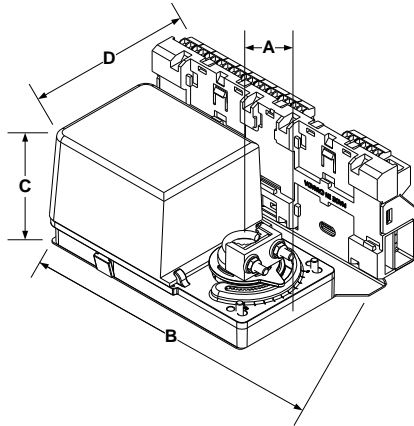

A = 1.50" | 39mm  
B = 7.25" | 185mm  
C = 3.25" | 83mm  
D = 5.50" | 140mm

**EVC with a separate 180 in. lb. Actuator**

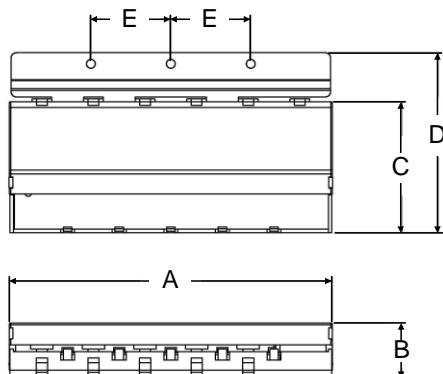

A = 7.20" | 183mm  
B = 1.23" | 31mm  
C = 2.93" | 74mm  
D = 4.02" | 102mm  
E = 1.78" | 45mm

## Digital Room Sensor Specifications

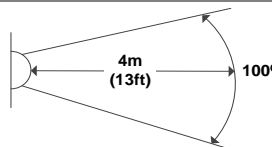
Description	TRL54 and TDU Series
<b>Temperature Sensor (TRL54 and TDU)</b>	
<i>Setpoint range</i>	10°C to 40°C [50°F to 104°F]
<i>Control accuracy</i>	Temperature: ±0.4°C [0.8°F]
<i>Display resolution</i>	±0.1°C [0.2°F]
<b>Humidity Sensor (TDU models with Humidity Sensors)</b>	
<i>Sensor range</i>	5 to 95%RH
<i>Display resolution</i>	0.1%
<b>CO<sub>2</sub> Sensor (TDU models with CO<sub>2</sub> Sensors)</b>	
<i>Operating principle</i>	Self-calibrating, Non-Dispersive Infrared (NDIR)
<i>Sensor Range</i>	0 to 2000 ppm
<i>Setpoint range</i>	100 to 2000 ppm
<i>Accuracy</i>	±30 ppm ±3% of reading
<i>Response time</i>	2 minutes by 90%
<i>Display resolution</i>	1 ppm
<b>PIR Motion Sensor (TDU00 / TDU 30 / TDU60 models with PIR Sensor)</b>	
<i>Operating Principle</i>	Passive Infrared (PIR)
<i>Detection Angle</i>	100°
<i>Detection Distance</i>	4m [13ft]
<i>Detection Area</i>	
<b>VOC Sensor (TDU00 / TDU30 / TDU60 models with VOC Sensor)</b>	
<i>Operating Principle</i>	Self-calibrating, Non-Dispersive Infrared (NDIR)
<i>Sensor Range</i>	0-1000 ppb isobutylene equivalent tVOCs
<i>Response Time</i>	<5 seconds for tVOC
<i>Start up Time</i>	15 minutes
<b>Other</b>	
<i>Electrical connection</i>	3 wires to VAV controller and 2 wires to BACnet/Modbus network   0.8 mm <sup>2</sup> [18 AWG] minimum
<i>Network service port</i>	Mini USB connector
<i>Power supply</i>	24Vac
<i>Power consumption</i>	1VA
<i>Operating temperature</i>	0°C to 50°C [32°F to 122°F]
<i>Storage temperature</i>	-30°C to 50°C [-22°F to 122°F]
<i>Relative humidity</i>	5 to 95 % non condensing
<i>Enclosure protection</i>	IP 30 (EN 60529)
<i>Weight</i>	120 g. [0.25 lb]



Dimensions

<p><b>TRL54</b></p> <p>A = 3.00"   78mm          B = 3.00"   78mm          C = 1.00"   24mm          D = 2.36"   60mm</p>	
<p><b>TDU10 / TDU40 / TDU70 Series</b></p> <p>A = 5.24"   133mm          B = 2.87"   73mm          C = 3.74"   95mm          D = 1.22"   31mm          E = 0.75"   19mm          F = 2.00"   51mm          G = 2.18"   55mm</p>	
<p><b>TDU00 / TDU30 / TDU60 Series</b></p> <p>A = 4.88"   124mm          B = 3.25"   83mm          C = 1.75"   44mm          D = 0.96"   24mm          E = 2.07"   53mm          F = 2.36"   60mm          G = 3.28"   83mm          H = 0.78"   20mm (without CO2)          0.95"   24mm (with CO2)</p>	



**TDU Models**

Horizontal Model #	Temp	RH	CO <sub>2</sub>
TDU10-100 TDU40-100 TDU70-100	•		
TDU10-101 TDU40-101 TDU70-101	•	•	
TDU10-102 TDU40-102 TDU70-102	•	•	•
TDU10-103 TDU40-103 TDU70-103	•		•



**TDU10 Series**



**TDU40 Series**



**TDU70 Series**

Vertical Model #	Temp	RH	CO <sub>2</sub>	PIR	VOC
TDU00-100 TDU30-100 TDU60-100	•				
TDU00-101 TDU30-101 TDU60-101	•	•			
TDU00-102 TDU30-102 TDU60-102	•	•	•		
TDU00-103 TDU30-103 TDU60-103	•		•		
TDU00-104 TDU30-104 TDU60-104	•			•	
TDU00-105 TDU30-105 TDU60-105	•	•		•	
TDU00-106 TDU30-106 TDU60-106	•	•	•		•
TDU00-107 TDU30-107 TDU60-107	•	•	•	•	•
TDU00-108 TDU30-108 TDU60-108	•	•	•	•	



**TDU00 Series**



**TDU30 Series**



**TDU60 Series**



**Interface**

**TRL54**



	Cooling ON A: Automatic		Programming mode (Technician setting)		Alarm status
	Heating ON A: Automatic		Menu set-up Lock		Energy saving mode
MIN MAX	Minimum/Maximum	°C or °F	°C: Celsius scale °F: Fahrenheit scale		

**TDU10 / TDU40 / TDU70 Series**

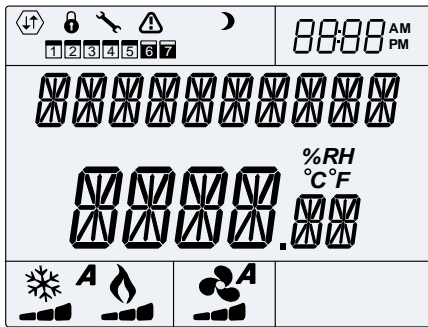

	Network Communication		User Lock		Programming Mode (Technician Setting)
	Alarm Status		Energy Saving Mode (NSB/OCC)		Schedule
8888:AM	Time	ppm	Parts Per Million	°C °F %RH	°C: Celsius Scale °F: Fahrenheit Scale %RH: Humidity
A	Automatic Mode		Cooling		Heating
			Fan		

**TDU00 / TDU30 / TDU60 Series**

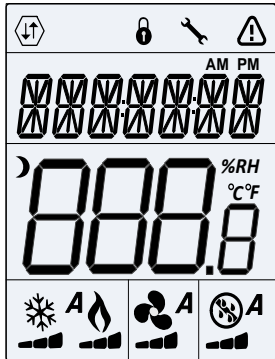

	Network Communication		User Lock		Programming Mode (Technician Setting)
	Alarm Status		Energy Saving Mode (NSB/OCC)	AM PM	Time
°C °F %RH	°C: Celsius Scale °F: Fahrenheit Scale %RH: Humidity	A	Automatic Mode		Cooling
	Heating		Fan		



### Mechanical Installation

1. Manually close the damper blades and position the actuator to 0° or 90°.
2. Slide the actuator onto the shaft.
3. Tighten the nuts on the "U" bolt to the shaft with an 8mm wrench to a torque of 60 in-lb [6.7 Nm].
4. Slide the mounting bracket under the actuator. Ensure free movement of the slot at the base of the actuator. Place the bracket pin at mid distance of the slot.
5. Affix the bracket to the ductwork with #8 self-tapping screws.



**Do not press the clutch when the actuator is powered.**

#### EVC with a built-in 70 in. lb. Actuator

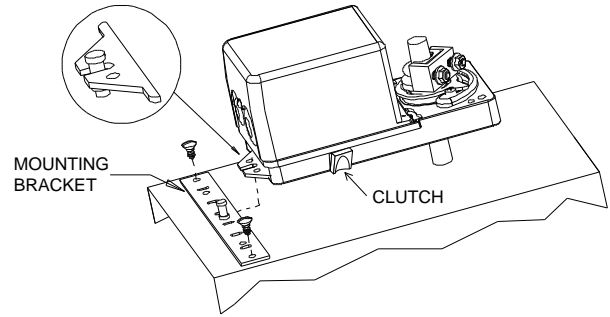

1. Manually close the damper blades and position the actuator to 0° or 90°.
2. Slide the actuator onto the shaft.
3. Tighten the nuts on the "U" bolt to the shaft with an 8mm wrench to a torque of 150 in.lb. [17 Nm].
4. Slide the mounting bracket under the actuator. Ensure free movement of the slot at the base of the actuator. Place the bracket pin at mid distance of the slot.
5. Affix the bracket to the ductwork with #8 self-tapping screws.
6. Connect the cable from the EVC to the terminal in the actuator as shown.



**Do not press the clutch when the actuator is powered.**

#### EVC with a separate 180 in. lb. Actuator

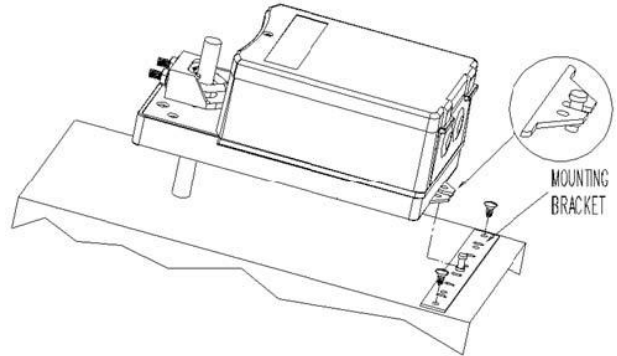

#### Terminals on the Actuator

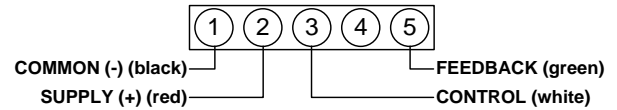

#### Signal cable from EVC controller (models EVCB14NIT4X and EVCB14NDT4X)

Use to connect the external motor on EVCB14NIT4X and EVCB14NDT4X.

- Green: Feedback
- White: Control
- Red: 24Vac
- Black: Common

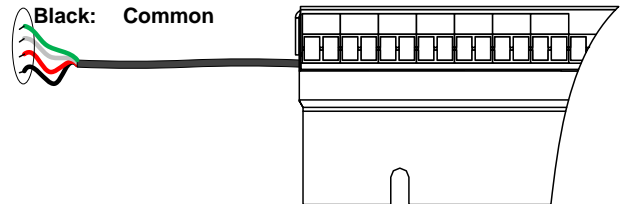



## Mounting Instructions

### TRL54

**⚠ CAUTION: Remove power to avoid a risk of malfunction.**

- Remove the captive screw that's holding the base and the front cover of the unit together.
- Lift the front cover of the unit to separate it from the base.
- Pull all wires through the holes in the base.
- Secure the base to the wall using wall anchors and screws (supplied). Make the appropriate connections.
- Mount the control module on the base and secure using the screw.

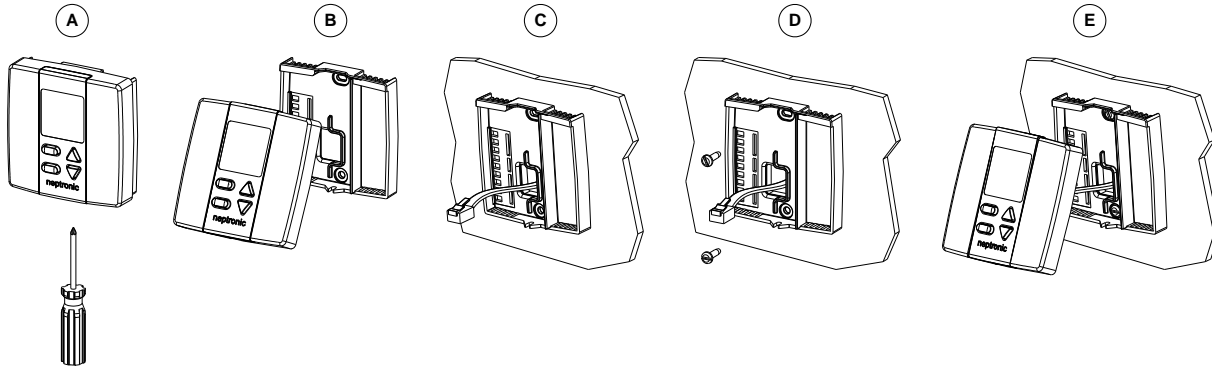

### TDU10 / TDU40 / TDU70 Series

**⚠ CAUTION: Remove power to avoid a risk of malfunction.**

- Remove the wall mounting plate (highlighted) from the back of the digital room sensor.
- Install the mounting plate on the gang box.
- Pull the wires through the base hole and make the appropriate connections.
- Mount the digital room sensor onto the wall plate. To mount it correctly, place the top of the digital room sensor on the mounting plate first and push it into the grooves to snap it into place.
- Secure the digital room sensor using the screw (supplied).

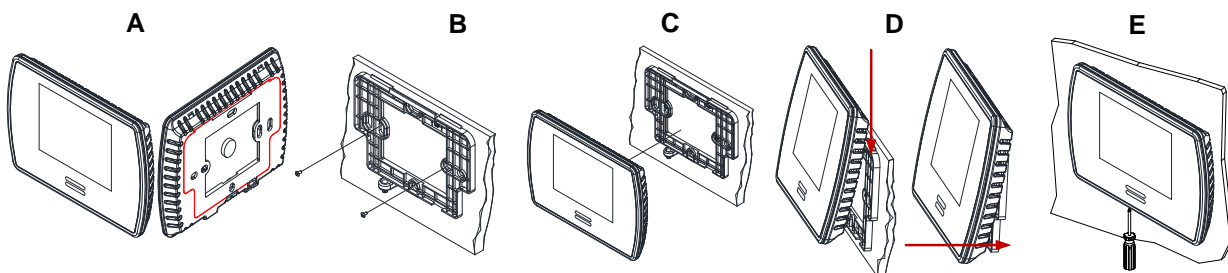

### TDU00 / TDU30 / TDU60 Series

**⚠ CAUTION: Remove power to avoid a risk of malfunction.**

- Remove the captive screw that's holding the base and the front cover of the unit together.
- Lift the front cover of the unit to separate it from the base.
- Pull all wires through the holes in the base.
- Secure the base to the wall using wall anchors and screws (supplied). Make the appropriate connections.
- Mount the control module on the base and secure using the screw.

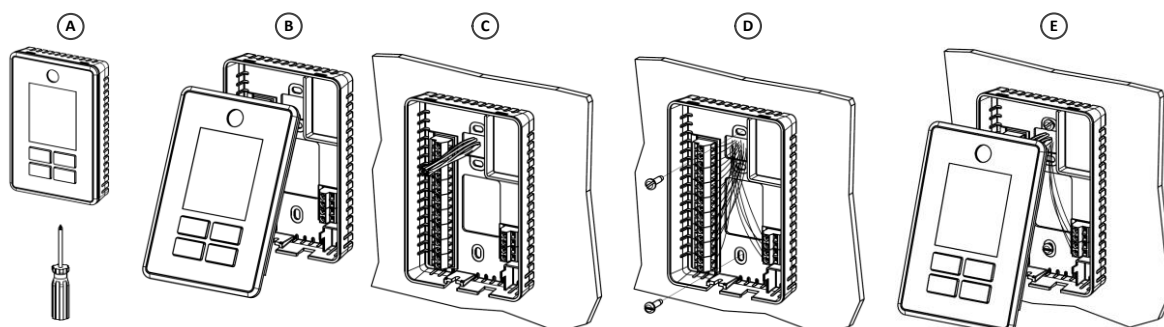





### BACnet or Modbus Address DIP Switch (DS1)

MAC address for communication, are selectable by DIP switch using binary logic. If you do not change device instance in program mode, it will be automatically modified according to the MAC address.



*Note: Avoid using addresses above 246 when selecting Modbus MAC address.*

MAC Address	DS.1 = 1	DS.2 = 2	DS.3 = 4	DS.4 = 8	DS.5 = 16	DS.6 = 32	DS.7 = 64	DS.8 = 128	Default Device Instance
0	OFF	OFF	OFF	OFF	OFF	OFF	OFF	OFF	153000
1	ON	OFF	OFF	OFF	OFF	OFF	OFF	OFF	153001
2	OFF	ON	OFF	OFF	OFF	OFF	OFF	OFF	153002
3	ON	ON	OFF	OFF	OFF	OFF	OFF	OFF	153003
4	OFF	OFF	ON	OFF	OFF	OFF	OFF	OFF	153004
...	...	...	...	...	...	...	...	...	...
126	OFF	ON	ON	ON	ON	ON	ON	OFF	153126
127	ON	ON	ON	ON	ON	ON	ON	OFF	153127

\* Slave addresses available by setting DS.8 to ON



### Wiring

We strongly recommend that all Neptronic products be wired to a separate grounded transformer and that transformer shall service only Neptronic products. This precaution will prevent interference with, and/or possible damage to incompatible equipment.

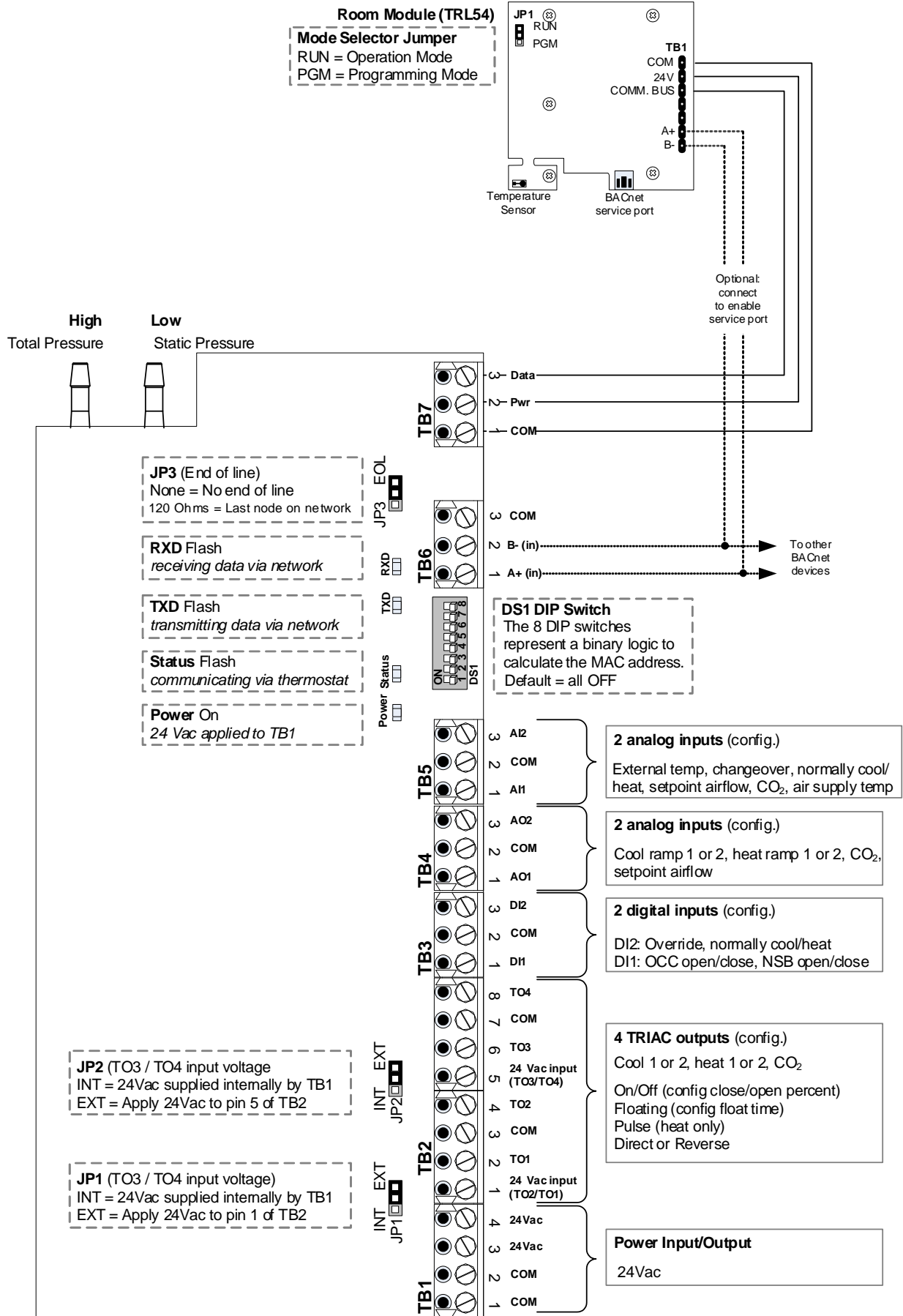

### PCB Drawings



#### TRL54 Digital Room Sensor

**3 wire cable (TB1 #1, 2 & 3)**

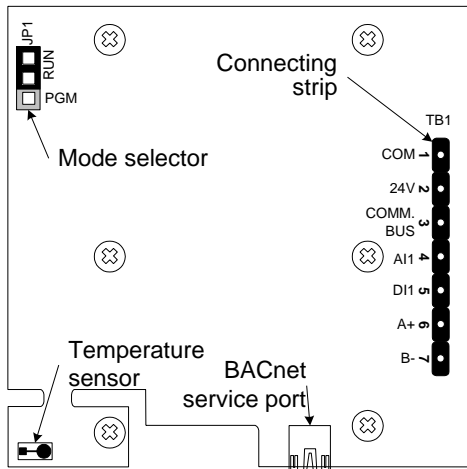
Connect TB1 #6 (A+) & #7 (B-) to EVCB to enable the BACnet service port.



#### Mode Selection (JP1)

	<p><b>Jumper (JP1) on RUN:</b> Digital room sensor is in <b>Operation Mode</b>. Digital room sensor must be set in this mode to operate properly. If not locked, setpoint and control mode (Heating &amp; Cooling ON, Cooling only ON or Heating only ON) can be modified by end user.</p>
	<p><b>Jumper (JP1) on PGM:</b> Digital room sensor is set in <b>Programming Mode</b>. Refer to following section about all settings description</p>



#### TDU10 / TDU40 / TDU70 Series Digital Room Sensor

**3 wire cable (TB1 #1, 2 & 3)**

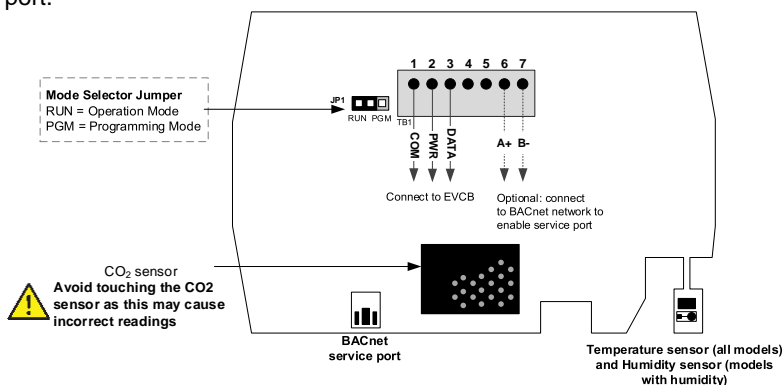
Connect TB1 #6 (A+) & #7 (B-) to EVCB to enable the BACnet service port.



#### Mode Selection (JP1)

	<p><b>RUN:</b> Digital room sensor is in <b>Operation Mode</b>. Digital room sensor must be set in this mode for normal system operation. If not locked, setpoint and control mode can be changed by the end user.</p>
	<p><b>PGM:</b> Digital room sensor is set in <b>Programming Mode</b>. Refer to the following sections for more details.</p>



#### TDU00 / TDU30 / TDU60 Series Digital Room Sensor

**3 wire cable (TB1 #1, 2 & 3)**

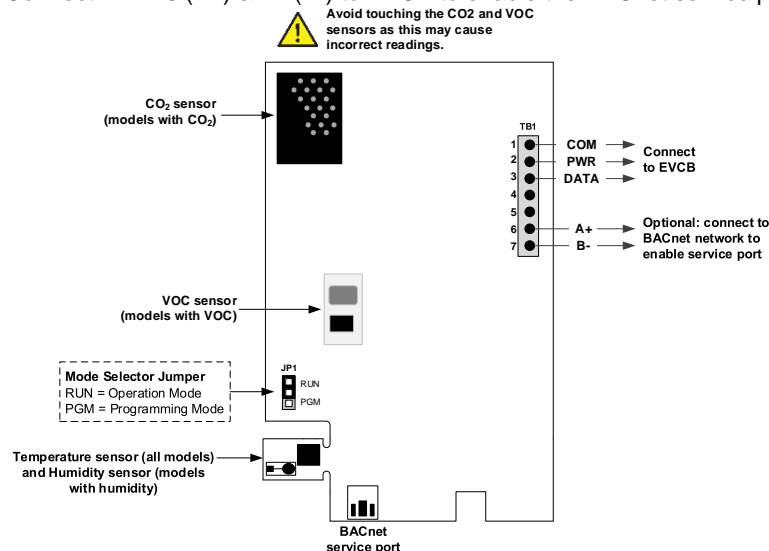
Connect TB1 #6 (A+) & #7 (B-) to EVCB to enable the BACnet service port.



#### Mode Selection (JP1)



	<p><b>RUN:</b> Digital room sensor is in <b>Operation Mode</b>. Digital room sensor must be set in this mode for normal system operation. If not locked, setpoint and control mode can be changed by the end user.</p>
	<p><b>PGM:</b> Digital room sensor is set in <b>Programming Mode</b>. Refer to the following sections for more details.</p>



## Access to Menus

The menu overviews and options are the same for both TRL54 and TDU digital room sensors. However, the action button or the button used to access the menus and save changes is different in the digital room sensors. Use the following menu overviews with the appropriate action button as per your digital room sensor.

### Action Buttons on Digital Room Sensor

Action Button		Task
TRL54	TDU	
		Press to access the programming menus and save any changes.
		Press to return to the previous step without saving.



*Note: Prior to going into Programming Mode, remove the connection cable between the EVCB and the TRL/TDU and set the Mode Selection jumper (JP1) to PGM on the digital room sensor. Reestablish the connection in order to access the programming menus and to make any changes. Once all menu changes have been made, remove the connection cable again before setting jumper JP1 back to RUN, and then reconnect the cable to resume normal operation.*

### Pressure & Applications – Menu Overview (1 of 6)

For a description of the default settings for each application refer to Annex A: Control Apps on page 23.

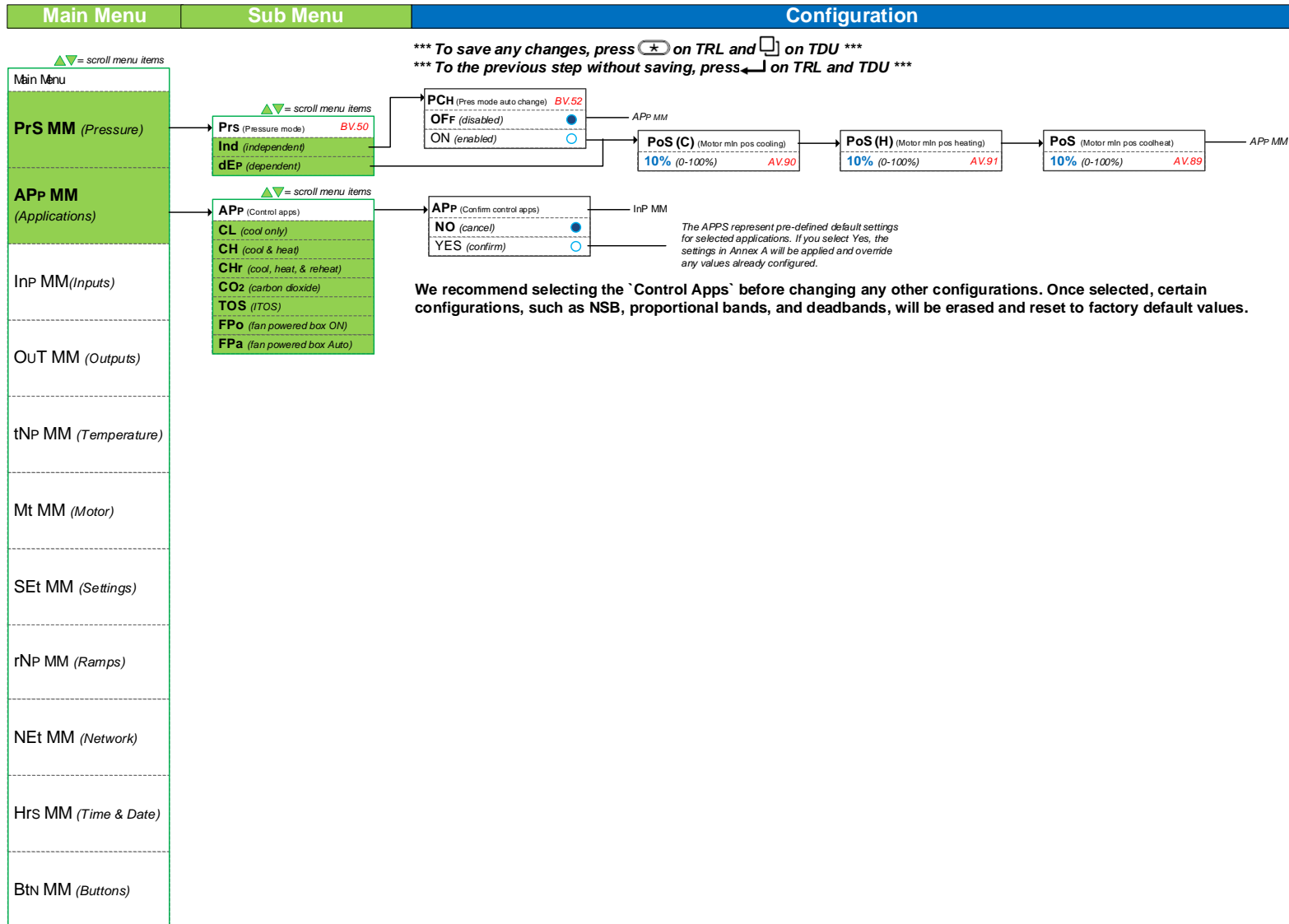

### Inputs – Menu Overview (2 of 6)

Main Menu      Sub Menu      Configuration

- Main Menu
- PrS MM (Pressure)
- APP MM (Applications)
- InP MM (Inputs)
- Out MM (Outputs)
- tNp MM (Temperature)
- Mt MM (Motor)
- SEt MM (Settings)
- rNp MM (Ramps)
- NEt MM (Network)
- Hrs MM (Time & Date)
- Btn MM (Buttons)

- InP (Configuration inputs)
- Al1
  - Al2
  - dl1
  - dl2
- \* = StF not available on pressure dependent models EVCB14NDT4S and EVCB14NDT4X
- † = Only available with EVCB14NIT0S models

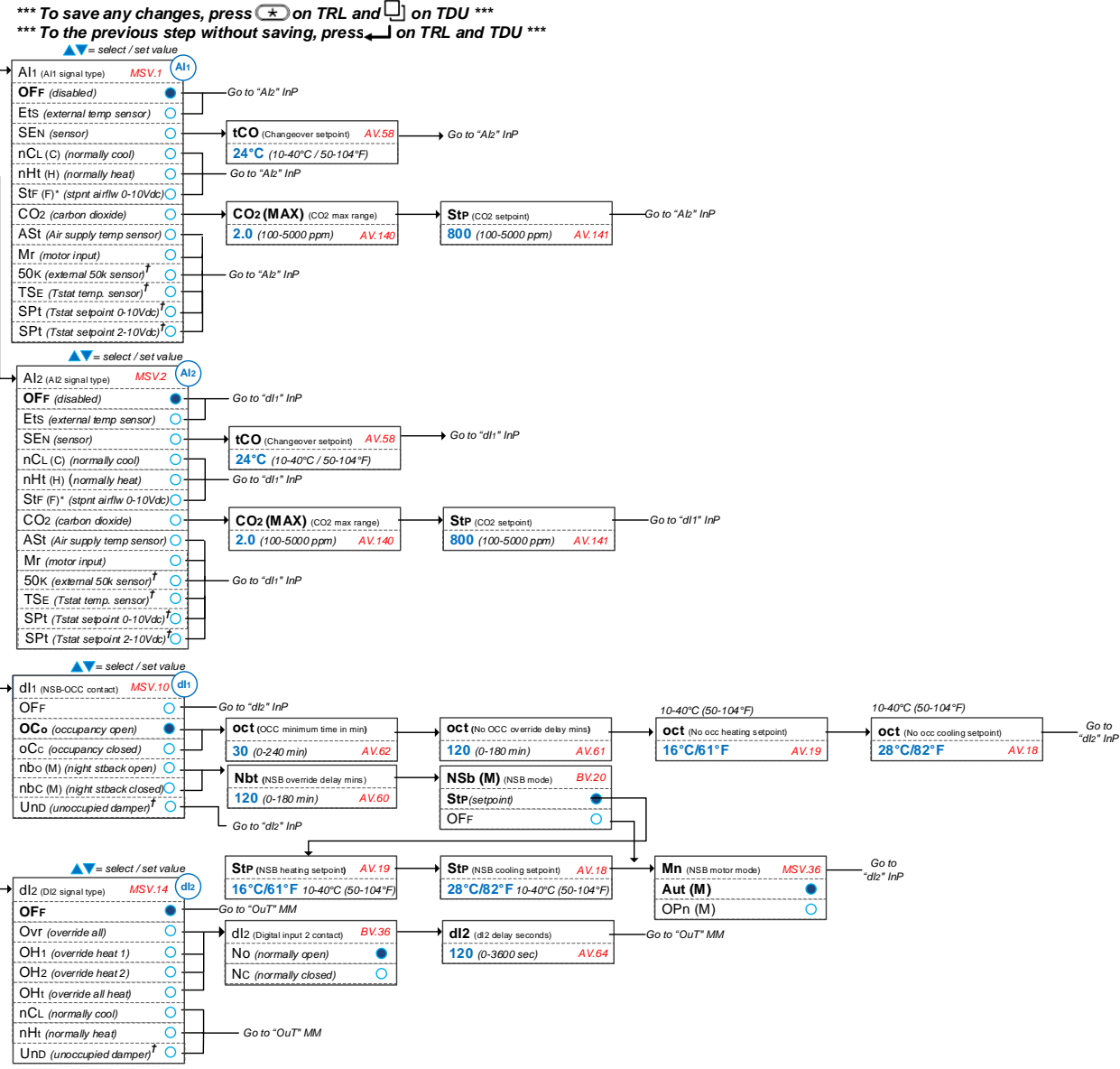



### TRIAC Outputs – Menu Overview (3 of 6)

Main Menu | Sub Menu | **Configuration**

\*\*\* To save any changes, press **\*** on TRL and **]** on TDU \*\*\*  
 \*\*\* To the previous step without saving, press **←** on TRL and TDU \*\*\*

- Main Menu
- PrS MM (Pressure)
- APP MM (Applications)
- InP MM (Inputs)
- Out MM (Outputs)**
- tNp MM (Temperature)
- Mt MM (Motor)
- SEt MM (Settings)
- rNp MM (Ramps)
- NEt MM (Network)
- Hrs MM (Time & Date)
- BtN MM (Buttons)

The number of Triac outputs (TO) depends on the model:

TOS = None  
 T2S = 2  
 T4S = 4

- Out (Output config)
- to1
- to2
- to3
- to4
- AO1
- AO2

† = Auto and On options are for fan powered box applications and are only available with models:

- EVCB14NIT4S
- EVCB14NDT4S
- EVCB14NIT4SF

§ = StF, Co, CH1, and ANA options, and 420 seconds maximum floating time are for external floating VAV damper actuators and are only available with models EVCB14NIT4X and EVCB14NDT4X.

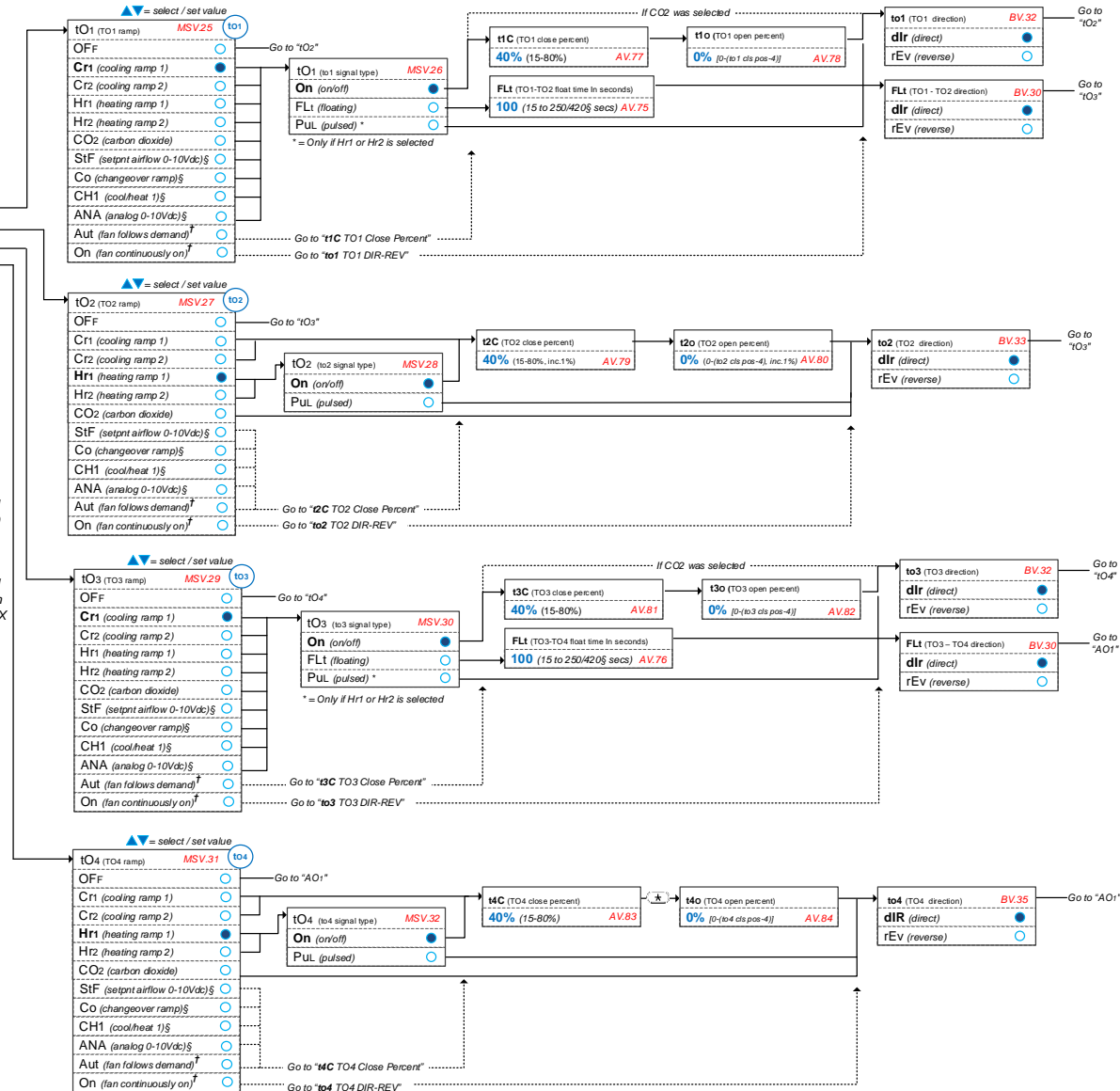

### Analog Outputs – Menu Overview (4 of 6)

Main Menu | Sub Menu | Configuration

\*\*\* To save any changes, press **★** on TRL and **□** on TDU \*\*\*  
 \*\*\* To the previous step without saving, press **←** on TRL and TDU \*\*\*

▲▼ = scroll menu items

Main Menu
PrS MM (Pressure)
APP MM (Applications)
InP MM (Inputs)
<b>OuT MM (Outputs)</b>
tNp MM (Temperature)
Mt MM (Motor)
SEt MM (Settings)
rNp MM (Ramps)
NEt MM (Network)
Hrs MM (Time & Date)
Btn MM (Buttons)

▲▼ = scroll menu items

Out (Output config)
tO1
tO2
tO3
tO4
<b>AO1</b>
<b>AO2</b>

§ = For models EVCB14NIT0S, the default value is Hr1  
 \* = StF not available on pressure dependent models EVCB14NDT4S and EVCB14NDT4X  
 † = Auto and On options are for fan powered box applications and are only available with models:  
 - EVCB14NIT4S  
 - EVCB14NDT4S  
 - EVCB14NIT4SF

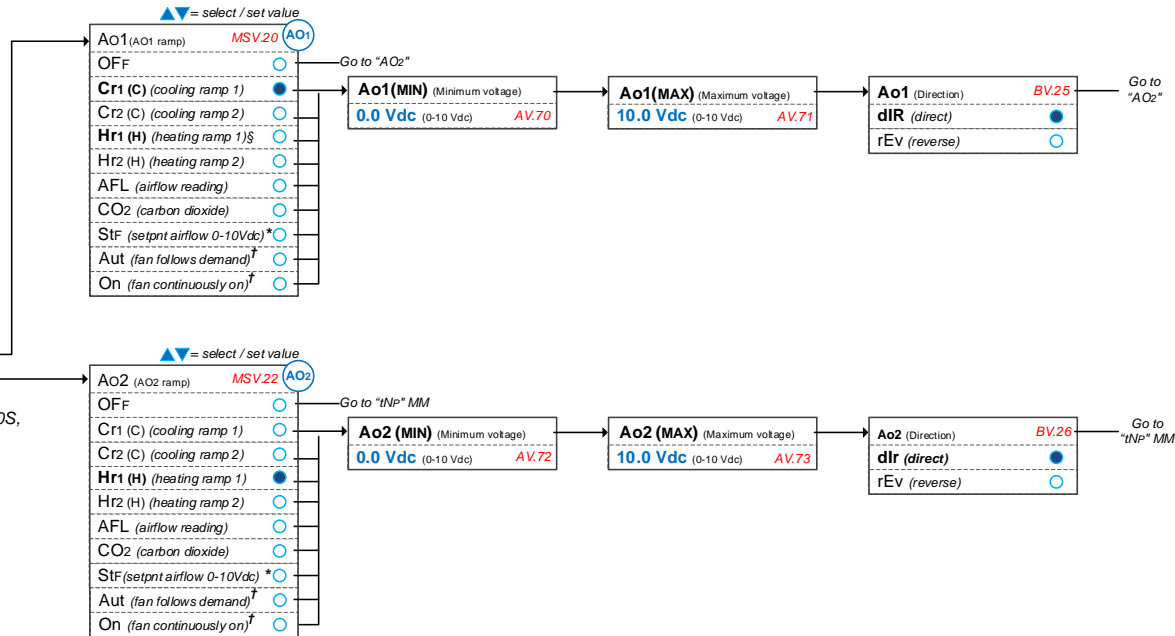

## Settings – Menu Overview (5 of 6)

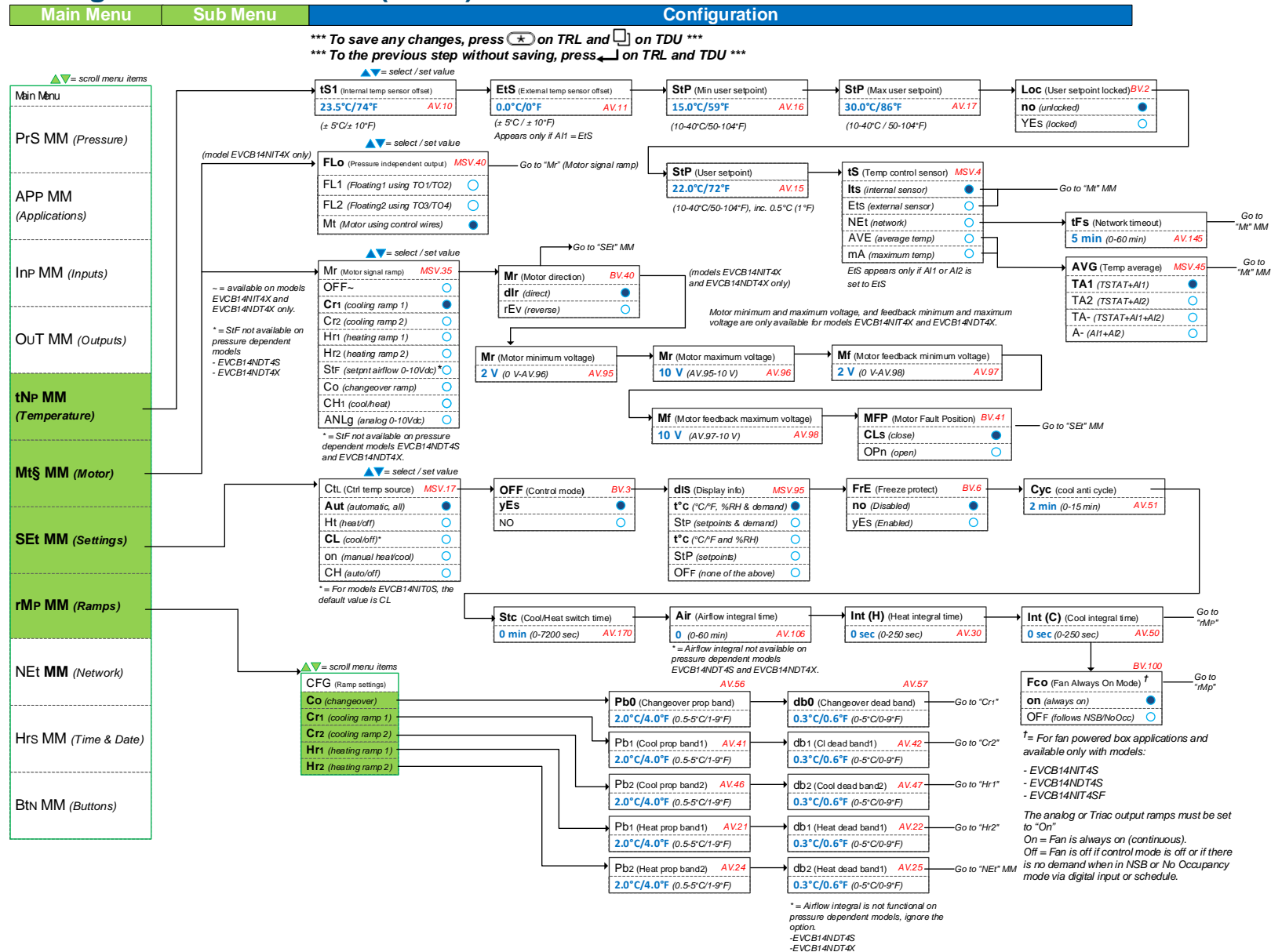

### Settings – Menu Overview (6 of 6)

Main Menu	Sub Menu	Configuration
-----------	----------	---------------



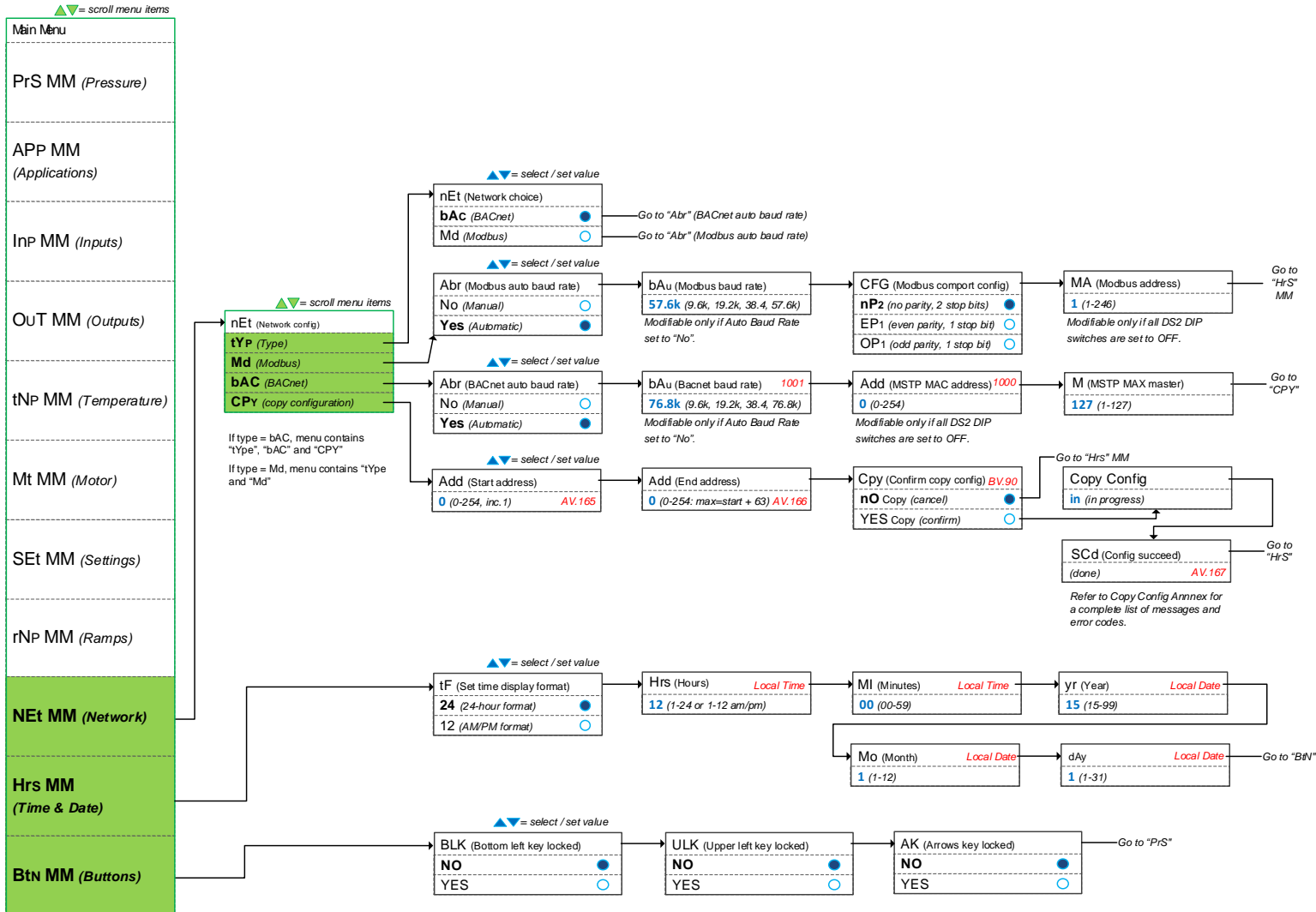



\*\*\* To save any changes, press **\*** on TRL and **]** on TDU \*\*\*  
 \*\*\* To the previous step without saving, press **←** on TRL and TDU \*\*\*



## Operation Menus

This menu is accessible through normal operation mode. The Mode Selector jumper (JP1) of the digital room sensor must be set to the "RUN" position (Operation Mode). Refer to Wiring on page 10.

Note: Since the action buttons are different on TRL and TDU digital room sensor series, both buttons have been included in the instructions. Refer to the Action Buttons on Digital Room Sensor section to know and use the button as available on your digital room sensor.

1. Press the [] / [] and [] buttons simultaneously for 5 seconds. The "ENTER PASSWORD" screen appears.
2. Enter the password within 1 minute by using the arrow keys to increase or decrease the value and the [] / [] and [] buttons to toggle between the digits.
  - b. Password **372** = Temperature Offset Menu
  - c. Password **637** = Network Settings Menu
  - d. Password **757** = Airflow Balance Mode
3. If you enter the wrong password, the digital room sensor displays "Error" and returns to Operation Mode. The digital room sensor will return to normal mode if you navigate through the entire menu and do not make any selection, or if you do not press any key for 5 minutes. The changed values will be saved automatically.

### Menu 372 – Temperature Offset

#### 1. "T5" (temperature sensor offset)



Range:	10 to 40°C	[50 to 104°F]
Offset:	Max ± 5°C	
Increment:	0.1°C	[0.2°F]

Compare the displayed temperature reading with a known value from a thermometer. To offset or calibrate the sensor, use the arrows key to set the desired temperature reading. This is useful for digital room sensors installed in areas where the temperature read is slightly different than the room's actual temperature. For example, a digital room sensor placed right under the air diffuser.

If the digital room sensor is set to use an external temperature sensor (**EtS**), the digital room sensor displays "OFF".

#### 2. "ETS" (external temperature sensor offset)



Range:	0 to 50°C	[41 to 122°F]
Offset:	Max ± 5°C	
Increment:	0.1°C	[0.2°F]

This option appears if you've set one of the analog inputs to **EtS** (External temperature sensor). When the digital room sensor is connected to the appropriate analog input, the display shows the temperature read by the external temperature sensor. Adjust the offset by comparing it with a known value (e.g. thermometer). If the sensor is not connected or short circuited, then the unit displays the sensor's limit.

#### 3. "PRS" (input 3 reading)



Range:	250mV (0") to 4000mV (1")
--------	---------------------------

Displays the voltage output value in mV of the pressure sensor. Does not appear for EVCB14NDT4S and EVCB14NDT4X (pressure dependant) models.

#### 4. "PRS MIN" (input 3 minimum reading)



Range:	10mV to 180mV
Default:	60mV

This setting represents the deadband of the pressure sensor in mV. For advanced users or special applications only. We recommend that you use the default setting of 60mV. Does not appear for EVCB14NDT4S and EVCB14NDT4X (pressure dependant) models.



Menu 637 – Network Settings

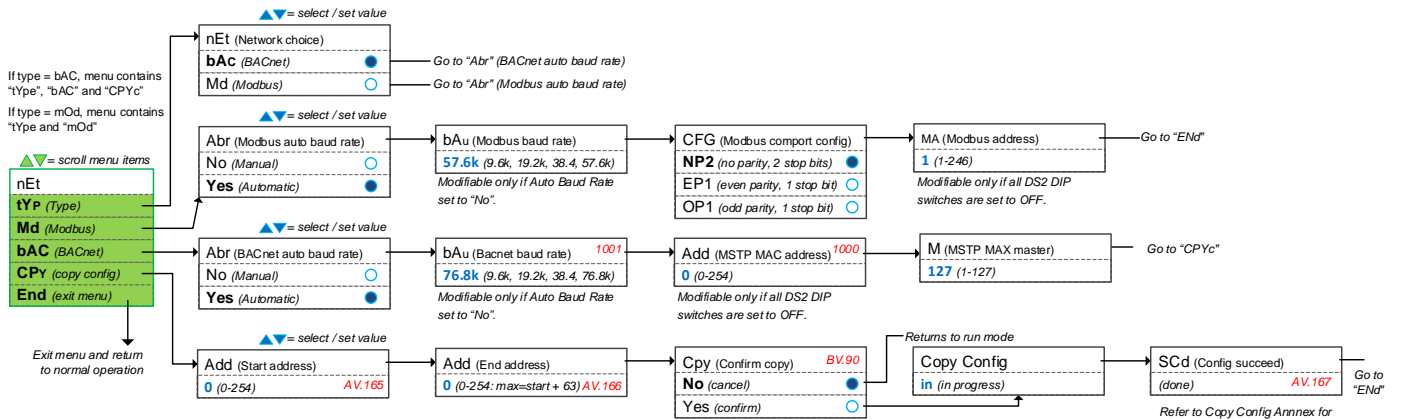

\*\*\* To save any changes, press \* on TRL and [ ] on TDU \*\*\*
\*\*\* To the previous step without saving, press [ ] on TRL and TDU \*\*\*

Menu 757 – Airflow Balance Mode

Pressure Independent: models EVCB14NIT0S, EVCB14NIT2S, EVCB14NIT4X and EVCB14NIT4S

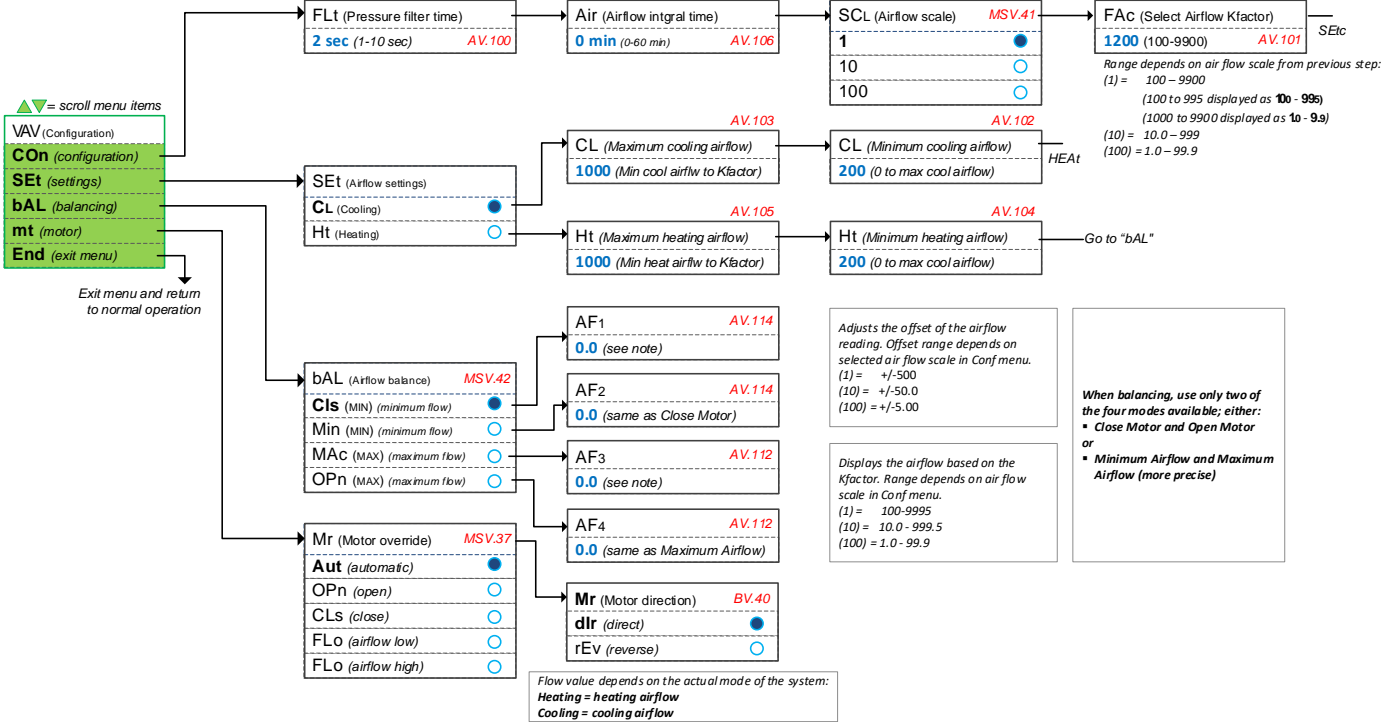

\*\*\* To save any changes, press \* on TRL and [ ] on TDU \*\*\*
\*\*\* To the previous step without saving, press [ ] on TRL and TDU \*\*\*



Note: Refer to EVCB-Airflow Balance Instructions on Neptronic website for further information on the airflow balancing function.

Pressure Dependent: models EVCB14NDT4S, EVCB14NDT4X or other models if in pressure dependent mode

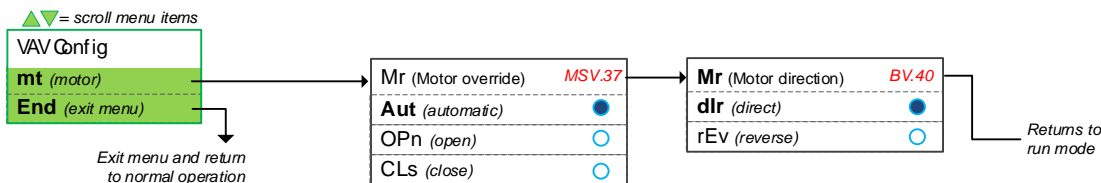

\*\*\* To save any changes, press \* on TRL and [ ] on TDU \*\*\*
\*\*\* To the previous step without saving, press [ ] on TRL and TDU \*\*\*











## Reset to Factory Default Settings



This will erase all actual configurations and replace them with the factory default settings.

1. The Mode Selector jumper (JP1) of the digital room sensor must be set to the "RUN" position (Operation Mode). Refer to Wiring on page 10.
2. During the power up sequence of the controller and digital room sensor, press and hold both the  and  buttons.
3. The "ENTERPASSWORD" screen appears. Enter **372** within 1 minute by using the arrow keys to increase or decrease the value and the [ / ] and  buttons to toggle between the digits.
4. Use the arrow buttons to select YES and then press [ / ].

### Operation Mode

The Mode Selector Jumper (JP1) of the digital room sensor must be set to the "RUN" position (Operation Mode). Refer to Wiring on page 10.

#### TRL54

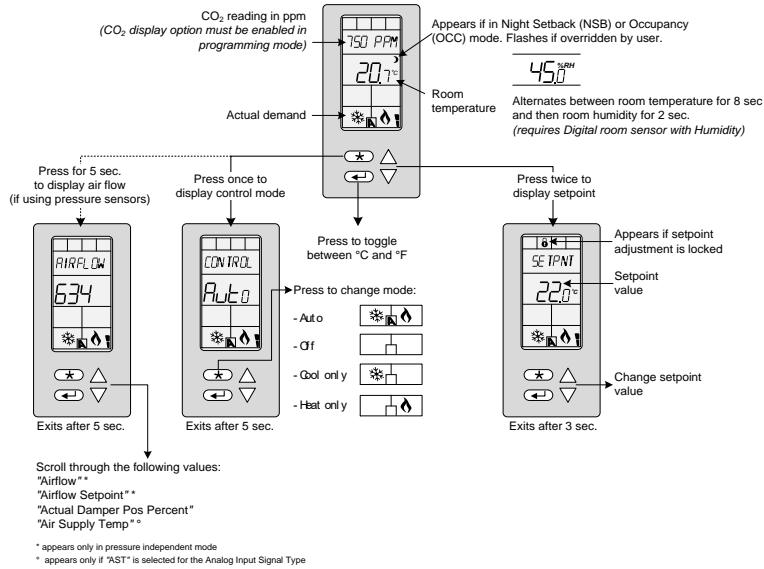

### TDU10 / TDU40 / TDU70 Series

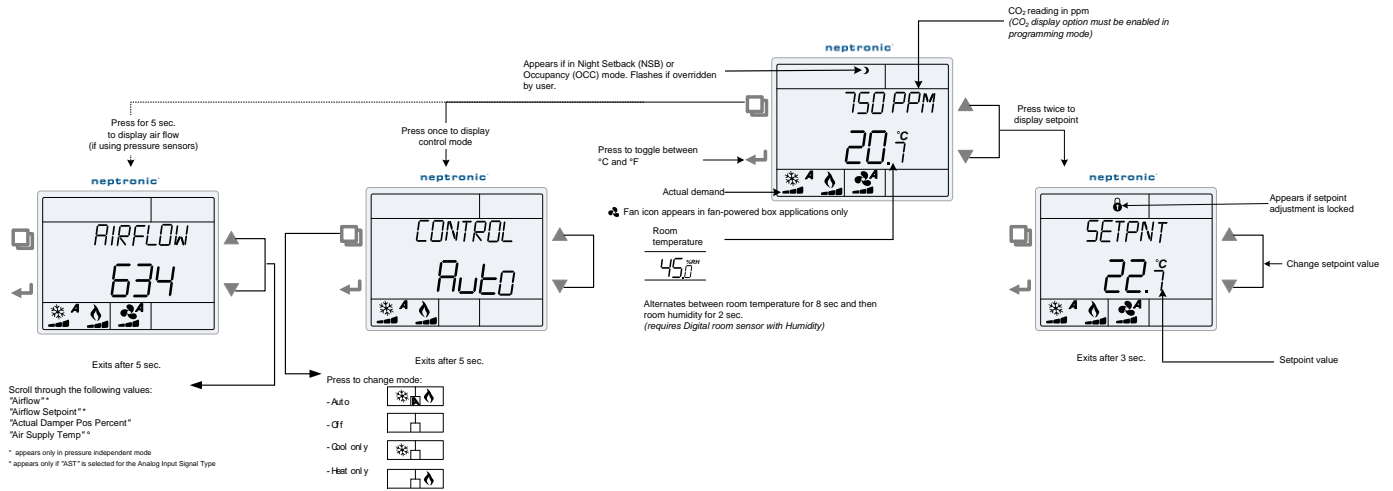

### TDU00 / TDU30 / TDU60 Series

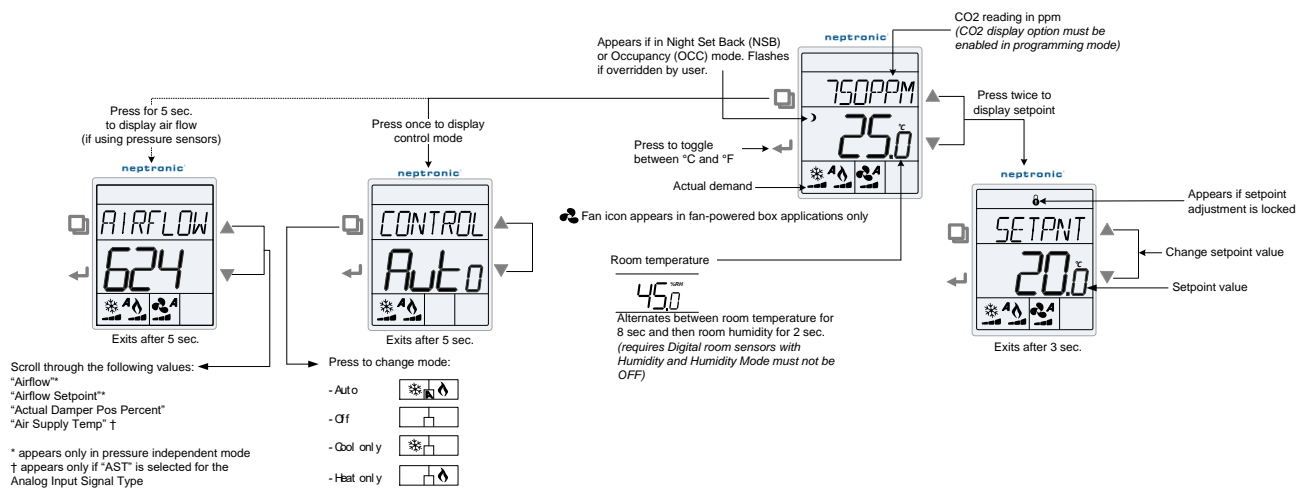

## Power Up

Upon power up, the LCD illuminates and all segments appear for 2 seconds. The digital room sensor then displays its current version of the digital room sensor for 2 seconds followed by the current version of the controller for 2 seconds. Pressing any key on the digital room sensor illuminates the LCD for 4 seconds.

## CO<sub>2</sub> (Digital Room Sensors with CO<sub>2</sub>)

If enabled via the configuration menu, the digital room sensor displays the CO<sub>2</sub> reading on the first line above the temperature reading. If CO<sub>2</sub> display is enabled, the time will not be displayed.

## Temperature Display and Setpoint

If enabled in the "Display Info" menu (see Settings – Menu Overview (5 of 6) on page 17), the digital room sensor displays the temperature reading. If the sensor is disconnected or short circuited, then the unit displays the sensor's limit. To toggle the temperature scale between °C and °F, press the  $\leftarrow$  button. To display the setpoint, press the  $\blacktriangle$  or  $\blacktriangledown$  key twice. The setpoint appears for 5 seconds. To adjust the setpoint, press the arrow keys while the temperature is displayed. If the setpoint adjustment has been locked "Setpnt Locked", the lock  $\mathcal{L}$  symbol appears.

## Humidity

If enabled in the "Options" menu (see Settings – Menu Overview (6 of 6) on page), the digital room sensor displays the temperature reading for 8 seconds and then displays the humidity reading for 2 seconds. If the sensor is disconnected or short circuited, then the unit displays the sensor's limit.

## Air Flow and Air Supply Temperature\*

Press and hold the  $\left[ \star / \square \right]$  button for 5 seconds and use the arrow keys to view the "AIRFLOW", "AIRFLOWSETPNT", "ACTUAL DAMPERPOS PERCENT" and "AIR SUPPLY TEMP". After 5 seconds without any action, the digital room sensor returns to operation mode. The air supply temperature appears only if analog input AI1 or AI2 are configured with the AST option. Not available on the following pressure dependent model *EVCB14NDT4S*.

## Control Mode

To access the Control Mode, press the  $\left[ \star / \square \right]$  button. The Control Mode appears for 5 seconds. Press the  $\left[ \star / \square \right]$  button to scroll through the following control modes. These options can vary depending on the options selected in "Temp Control Mode" and "Enable OnOff Control Mode".

- Auto (Automatic Cooling or Heating)
- OFF (if it is not disabled in Programming Mode)
- Cooling only (on, with cooling symbol)
- Heating only (on, with heating symbol)

## Night Set Back (NSB) or Occupancy Mode

This function is only available if you set DI1 to **nSb** (Night set back contact) or **Occ** (occupancy mode). If the DI1 contact is triggered, the digital room sensor enters NSB or No Occupancy Mode (the  $\curvearrowright$  symbol appears) and uses the NSB or OCC heating and cooling setpoints.

If not locked, you can override the night set back or no occupancy mode for a predetermined period by pressing any of the 4 buttons. During the override period the  $\curvearrowright$  symbol will flash. If the  $\curvearrowright$  symbol does not flash, the override period is finished or the night set back or no occupancy override has been locked in programming mode.

## Set Time and Date

1. Ensure that JP1 on the digital room sensor is set to run.
2. Press and hold the  $\leftarrow$  button for 5 seconds.
3. Use the arrow keys to set the desired value. Press the  $\left[ \star / \square \right]$  button to save and got to the next step. Press the  $\leftarrow$  button to go to the previous step without saving.

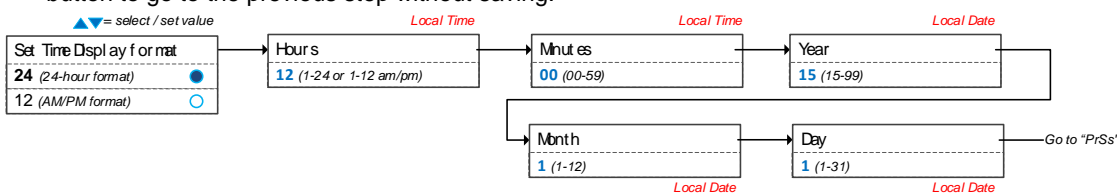

\*\*\* To save any changes, press  $\left[ \star \right]$  on TRL and  $\left[ \square \right]$  on TDU \*\*\*

\*\*\* To the previous step without saving, press  $\leftarrow$  on TRL and TDU \*\*\*

Note: Time will only be displayed on the TDU when the Bacnet scheduler is active. In order to achieve this, set the proper BACnet Object present value to Yes (1): *EVCB BV.70 – Cfg\_ActiveSchedule*.

## Annex A: Control Apps

Refer to Pressure & Applications – Menu Overview (1 of 6) on page 13 for more information. The available **Control Apps** vary according to the model.

Description	CL (cool only)	CLHt (cool/heat)	CHrH (cool/heat/reheat)	CO2 (CO2)	ITOS (ITOS)	FPbo (fan powered ON)	FPbA (fan powered Auto)
Min. Setpoint	<b>20°C (68°F)</b>	<b>20°C (68°F)</b>	<b>20°C (68°F)</b>	<b>20°C (68°F)</b>	15°C (59°F)	15°C (59°F)	15°C (59°F)
Max. Setpoint	<b>28°C (82°F)</b>	<b>28°C (82°F)</b>	<b>28°C (82°F)</b>	<b>28°C (82°F)</b>	30°C (86°F)	30°C (86°F)	30°C (86°F)
Changeover Setpnt	24°C (75°F)	<b>20°C (68°F)</b>	<b>20°C (68°F)</b>	<b>20°C (68°F)</b>	24°C (75°F)	24°C (75°F)	24°C (75°F)
TO1 Ramp	<b>HR1</b>	CR1	<b>HR1</b>	CR1	<b>OFF</b>	<b>HR1</b>	<b>HR1</b>
TO1 Signal Type	On/Off	On/Off	On/Off	On/Off	On/Off	On/Off	On/Off
TO1 Close Pos.	40%	40%	40%	40%	40%	<b>35%</b>	<b>35%</b>
TO1 Open Pos.	0%	0%	0%	0%	0%	0%	0%
TO2 Ramp	HR1	HR1	HR1	<b>CO2</b>	<b>OFF</b>	HR1	HR1
TO2 Signal Type	<b>Pulse</b>	On/Off	<b>Pulse</b>	On/Off	On/Off	On/Off	On/Off
TO2 Close Pos.	40%	40%	40%	40%	40%	<b>70%</b>	<b>70%</b>
TO2 Open Pos.	0%	0%	0%	0%	0%	<b>35%</b>	<b>35%</b>
TO3 Ramp	<b>HR2</b>	<b>CR2</b>	<b>HR2</b>	<b>HR1</b>	<b>OFF</b>	<b>Fan ON</b>	<b>Fan Auto</b>
TO3 Signal Type	On/Off	On/Off	On/Off	On/Off	On/Off	On/Off	On/Off
TO3 Close Pos.	40%	40%	40%	40%	40%	40%	40%
TO3 Open Pos.	0%	0%	0%	0%	0%	0%	0%
TO4 Ramp	<b>HR2</b>	<b>HR2</b>	<b>HR2</b>	<b>HR1</b>	<b>OFF</b>	<b>HR1</b>	<b>HR1</b>
TO4 Signal Type	<b>Pulse</b>	On/Off	<b>Pulse</b>	On/Off	On/Off	On/Off	On/Off
TO4 Close Pos.	40%	40%	40%	40%	40%	40%	40%
TO4 Open Pos.	0%	0%	0%	0%	0%	0%	0%
Motor Ramp	CR1	<b>COr</b>	<b>COr</b>	<b>COr</b>	CR1	CR1	<b>COr</b>
AO1 ramp	<b>HR1</b>	CR1	<b>HR1</b>	CR1	<b>HR1</b>	<b>HR1</b>	<b>HR1</b>
AO2 Ramp	<b>HR2</b>	HR1	<b>HR2</b>	HR1	<b>OFF</b>	<b>HR2</b>	<b>Fan Auto</b>
AI1 Input	OFF	<b>SENS</b>	<b>SENS</b>	<b>SENS</b>	OFF	OFF	<b>SENS</b>
AI2 Input	OFF	OFF	OFF	<b>CO2</b>	OFF	OFF	OFF
DI1 Input	<b>nSb.o</b>	<b>nSb.o</b>	<b>nSb.o</b>	Occ.o	Occ.o	<b>nSb.o</b>	<b>nSb.o</b>
Heat Prop Band 2	2°C (4°F)	2°C (4°F)	2°C (4°F)	2°C (4°F)	2°C (4°F)	<b>1°C (2°F)</b>	<b>1°C (2°F)</b>
Heat Deadband 2	<b>1.3°C (2.6°F)</b>	<b>1.3°C (2.6°F)</b>	<b>1.3°C (2.6°F)</b>	<b>1.3°C (2.6°F)</b>	0.3°C (0.6°F)	<b>1.3°C (2.6°F)</b>	<b>1.3°C (2.6°F)</b>
Cool Deadband 2	<b>1.3°C (2.6°F)</b>	<b>1.3°C (2.6°F)</b>	<b>1.3°C (2.6°F)</b>	<b>1.3°C (2.6°F)</b>	0.3°C (0.6°F)	0.3°C (0.6°F)	0.3°C (0.6°F)

## Legend

Grey Text = Standard default value

**Bold Text** = Special default value for selected application

- HR = Heating ramp
- CR = Cooling ramp
- COr = Changeover ramp
- SENS = Changeover temperature sensor
- Fan ON = Fan powered box in continuous mode
- Fan Auto = Fan powered box in automatic mode (follows demand)
- nSb.o = Night Set Back (normally open)
- Occ.o = Occupancy mode (normally open)
- TO = TRIAC output
- AO = Analog output
- AI = Analog input
- DI = Digital input



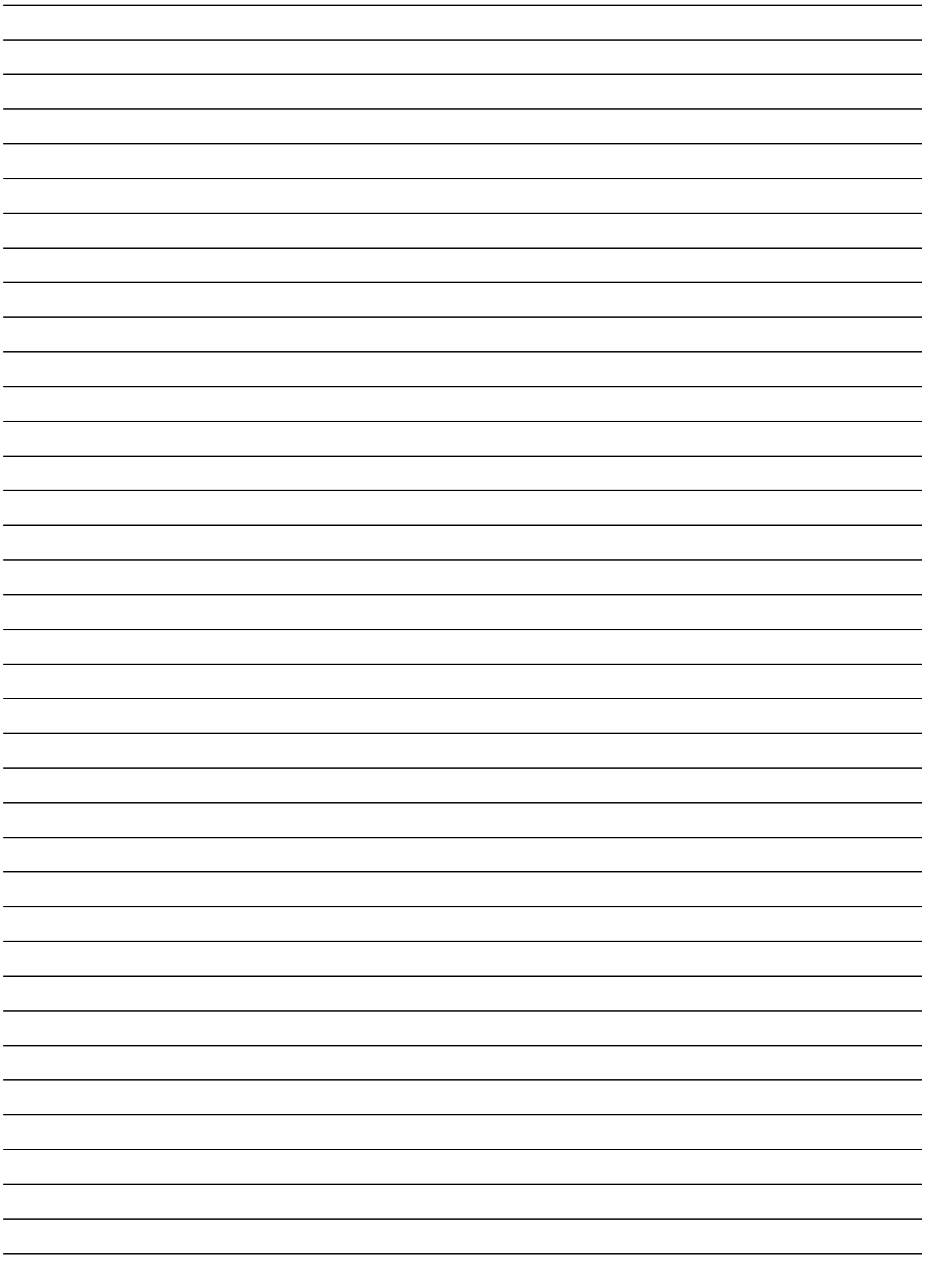



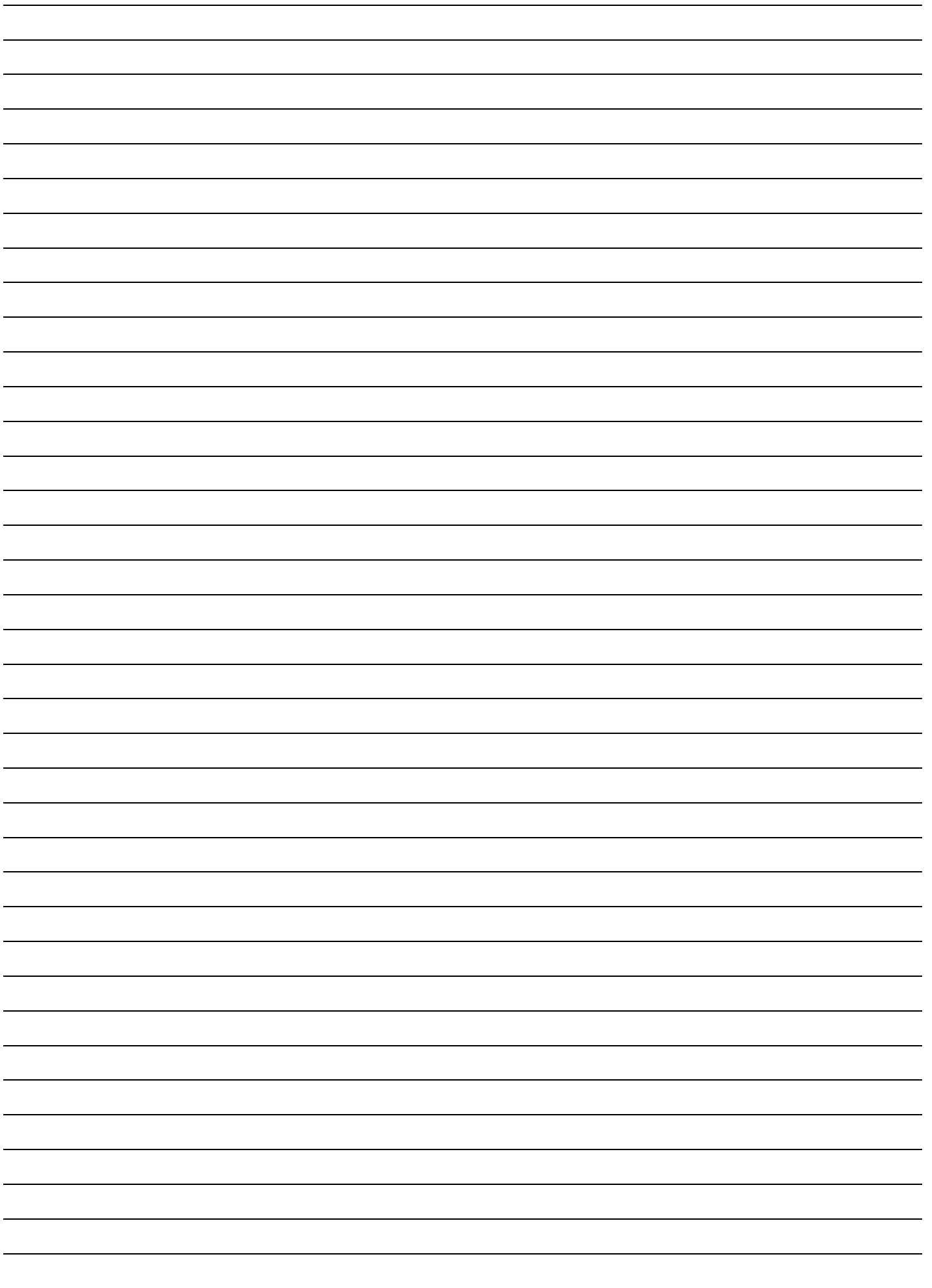



Recycling at end of life: please return this product to your Neptronic local distributor for recycling. If you need to find the nearest Neptronic authorized distributor, please consult [www.neptronic.com](http://www.neptronic.com).



**neptronic**<sup>®</sup>

400 Lebeau Blvd, Montreal, Qc, H4N 1R6, Canada

[www.neptronic.com](http://www.neptronic.com)

Toll free in North America: 1-800-361-2308

Tel.: (514) 333-1433

Fax: (514) 333-3163

Customer service fax: (514) 333-1091

Monday to Friday: 8:00am to 5:00pm (Eastern time)