



Features:

- Clutch for manual adjustments.
- Maintenance free.
- Position indicator.
- Control signal fully programmable.
- Brushless DC driven motor.
- Fail safe by *Enerdrive System*¹ (on model 260 & 280).
- Auxiliary switches (on model 260 & 280).

TM200N
TM220N
TM260N
TM280N
RM200N
RM220N
RM260N
RM280N

Technical Data	TM200N	TM220N	TM260N	TM280N	RM200N	RM220N	RM260N	RM280N
Auxiliary switches	No	Yes (2)	No	Yes (2)	No	Yes (2)	No	Yes (2)
Fail safe - Enerdrive	No		Yes		No		Yes	
Power consumption	20 VA		45 VA Peak, 20 VA		30 VA		50 VA Peak, 30 VA	
Torque	180 in.lb. [20 Nm] at rated voltage				360 in.lb. [40 Nm] at rated voltage			
Running time through 90°	40 to 50 sec torque dependant							
Power supply	28 to 32 Vdc or 22 to 26 Vac, 220 to 250 Vac 50/60Hz							
Feedback	4 to 20 mA or 2 to 10 Vdc adjustable							
Electrical connection	18 AWG [0.8 mm ²] minimum							
Inlet bushing	2 inlet bushing of 7/8 in [22.2 mm]							
Control signal	Analog, Digital or PWM programmable (factory set with analog control signal)							
Angle of rotation	0 to 90 degrees, electronically adjustable (factory set with 90° stroke)							
Direction of rotation	Reversible, Clockwise (CW) or Counterclockwise (CCW) (factory set with CW direction)							
Operating temperature	0°F to 122°F [-18°C to 50°C]							
Storage temperature	-22°F to 122°F [-30°C to 50°C]							
Relative Humidity	5 to 95 % non condensing.							
Weight	5 lbs. [2.3 kg]				8 lbs. [3.5 kg]			
Warning: Do not press the clutch when actuator is powered								

Dimensions

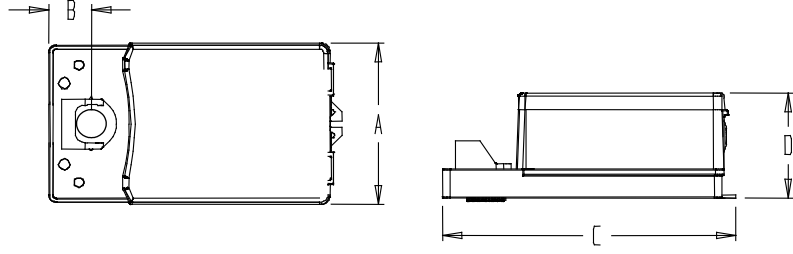

Dimension	Imperial (in)	Metric (mm)
A	5.20	132.1
B	1.33	33.8
C	9.13	231.9
D	3.55	90.2

Caution

We strongly recommend that all Neptronic® products be wired to a separate transformer and that transformer shall service only Neptronic® products. This precaution will prevent interference with, and/or possible damage to incompatible equipment.
When multiple actuators are wired on a single transformer, polarity must be observed. Long wiring runs create voltage drop which may affect the actuator performance.

¹ Enerdrive System U.S.A. Patent #5,278,454



Mechanical Installation

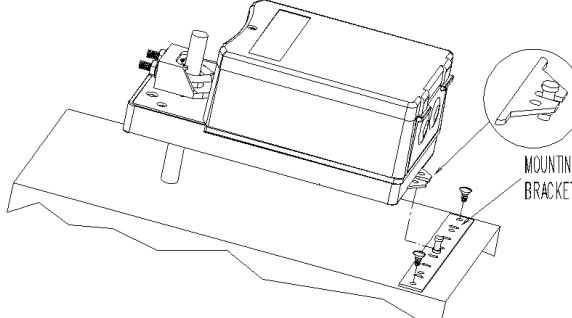

1. Manually close the damper blades and positioned the actuator at 0° or 90°.
2. Slide the actuator onto the shaft.
3. Tighten the nuts on the “U” bolt to the shaft with a 10mm wrench to a torque of 150 in.lb. [17 Nm].
4. Slide the mounting bracket under the actuator. Ensure free movement of the slot at the base of the actuator. The bracket pin must be placed in the mid distance of the slot.
5. Fix the bracket to the ductwork with #8 self-tapping screws.

Wiring Diagrams

Analog line voltage

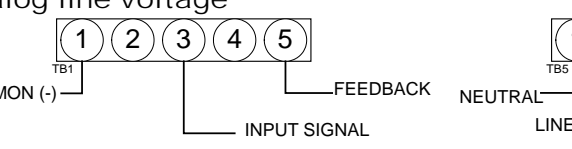

Analog low voltage

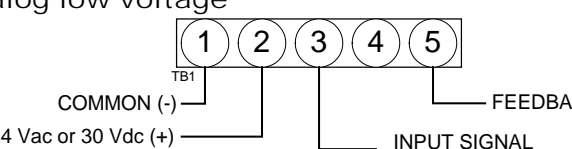

Digital signal from internal source

Digital – 3 wire / 2 position

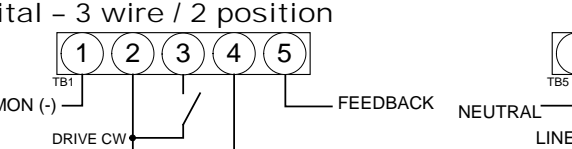

Digital – 4 wire / 3 point floating

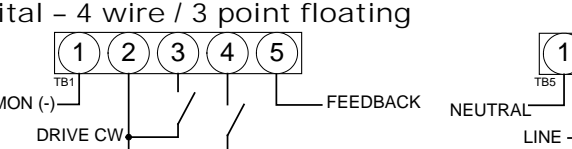

Digital signal

Digital – 3 wire / 2 position

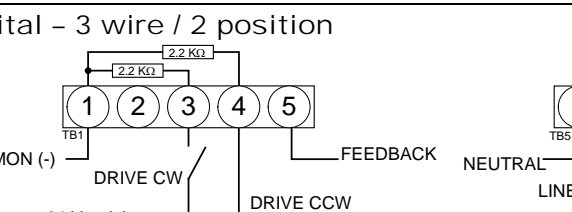

Digital – 4 wire / 3 point floating

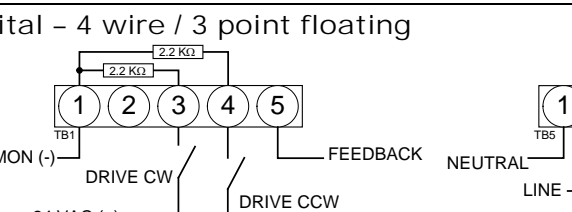

Special consideration for Digital control
In this mode, the actuator is sensitive to induced electrical voltages **from external sources**. To prevent such interference, if the signal on pins 4 and 3 on TB1 are from an **external 24 Vac source**, install a resistor 2.2kohm, 0.5W between pins 4 and 1 and another of 2.2kohms, 0.5W between pins 3 and 1 of TB1. These resistors are included.

Input Signal and Feedback setup

	Input Signal	Feedback
Analog Mode	Input Signal is set with Dipswitch # 3 DS1-3 at OFF = 2 – 10Vdc (default setting) DS1-3 at ON = 4 – 20mA	Feedback is set with Dipswitch #4 DS1-4 at OFF = 4 – 20mA (default setting) DS1-4 at ON = 2 – 10Vdc
Digital & PWM Mode	No Input Signal Setting DS1-3 MUST be at OFF	

PC Board

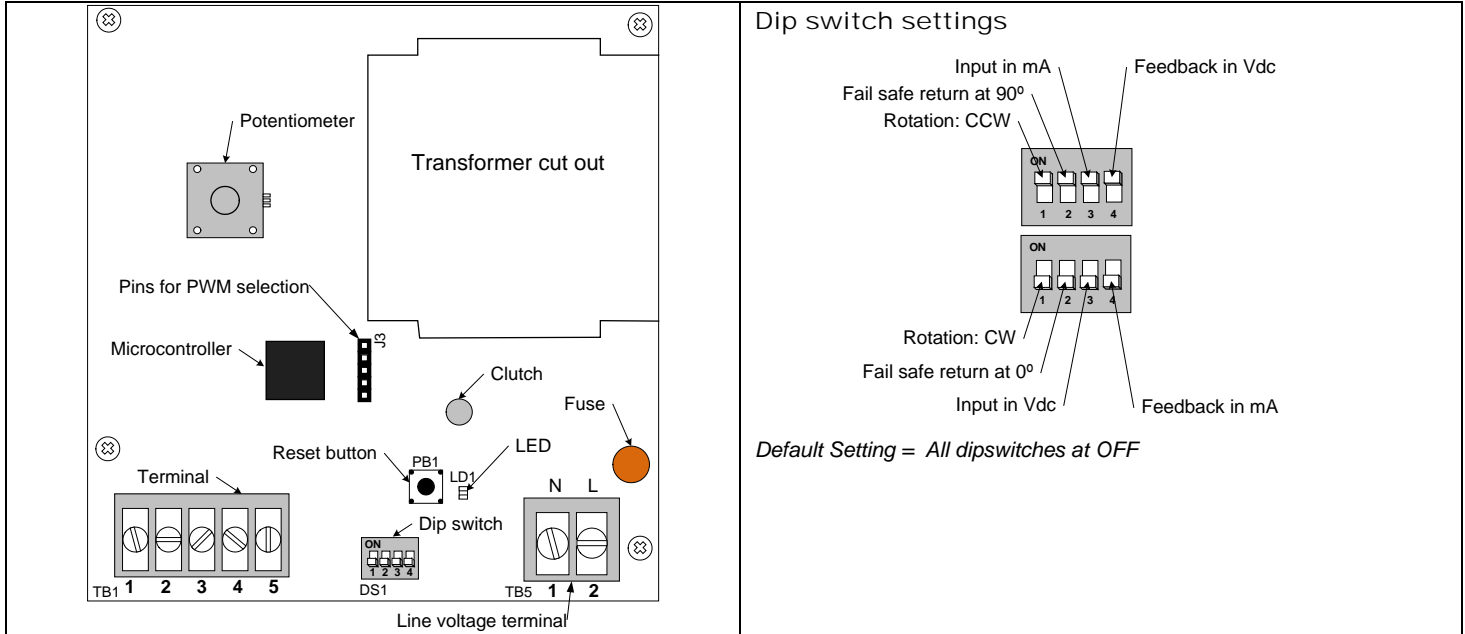

Stroke adjustment – No control signal change

1. Apply power and, **WAIT FOR LED TO BE OFF (around 10 seconds)**.
2. Press and release the reset button to start the auto-stroke process. The LED should be illuminated.
 - **First option:**
The actuator will then travel in both directions to find its limit and position itself according to the demand. The LED will extinguish, the process is complete.
 - **Second option:**
When the desired start position is reached, press and release the reset button. The actuator will now go the end position. (you can also press and release the reset button when it reaches the end position) The LED will extinguish, the process is complete.

Programming – Change of control signal & PWM pulse setting

1. Remove power and put all dip switches "OFF". (factory preset).
2. Apply power and, **within 10 seconds**, press and release the reset button. The LED should be blinking.
3. Select the control signal with dip switches:

	Digital or Analog Modes	PWM Mode
Move switch No1 "ON" and then "OFF".	Digital (On/Off or 3 point floating)	5 sec. pulse (factory preset)
Move switch No2 "ON" and then "OFF".	Analog (Default)	25 sec. pulse

4. Stroke adjustment
see the stroke adjustment section above.

Enabling or disabling PWM mode

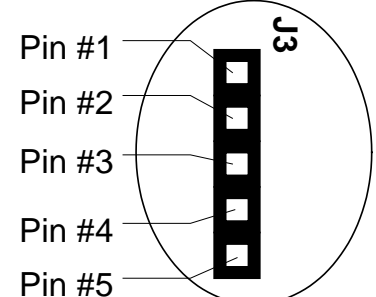
<ol style="list-style-type: none"> 1. Remove power supply to actuator 2. Install jumper between pin 3 & 4 of J3 3. Select the desired action using the dipswitches (DS1): <table border="1" style="margin: 5px 0; border-collapse: collapse; width: 100%;"> <thead> <tr> <th style="width: 15%;">DS1-1</th> <th style="width: 15%;">DS1-2</th> <th style="width: 70%;">Action</th> </tr> </thead> <tbody> <tr> <td style="text-align: center;">OFF</td> <td style="text-align: center;">ON</td> <td>Enable PWM Mode</td> </tr> <tr> <td style="text-align: center;">ON</td> <td style="text-align: center;">OFF</td> <td>Disable PWM Mode</td> </tr> </tbody> </table> 4. Re-apply power supply to actuator 5. Wait 5 seconds 6. Remove power supply to actuator 7. Remove jumper between pin 3 & 4 of J3, re-install it between pin 4 & 5. 8. Re-apply power supply to actuator <i>PWM is factory preset at 5 sec. pulse, refer to programming section above to change pulse setting.</i> 	DS1-1	DS1-2	Action	OFF	ON	Enable PWM Mode	ON	OFF	Disable PWM Mode	 <p style="text-align: center; font-size: small;">When not used for programming, jumper is placed between pin 4 & 5</p>
DS1-1	DS1-2	Action								
OFF	ON	Enable PWM Mode								
ON	OFF	Disable PWM Mode								

Zero and span calibration

This feature is applicable to analog control signal only.

1. Remove power and put all dip switches "OFF". (factory preset).
2. Apply power and, **within 10 seconds** press and **hold** the reset button until the LED blinks once. The Zero and span calibration process then start.
3. Release the reset button. The LED is now constantly illuminated.
4. Apply new minimum voltage.
It can be any value between 0 to 7 Vdc, with an external 0 to 10 volt supply (ex: MEP).
5. Press and release the reset button to memorize the new minimum voltage. The LED blinks.
6. Apply new maximum voltage.
It can be any value between 3 to 10 Vdc, this value should be greater than the new minimum value.
7. Press and release the reset button to memorize the new maximum voltage. The LED blinks. The Zero and span calibration process is complete.

Note: To reset zero and span to 2 to 10 Vdc (factory value). You just have to re-select the analog control signal mode, see Programming.

Wiring Diagrams for auxiliary switches (on model 220 & 280)

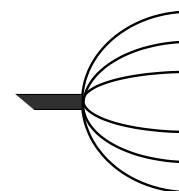
	<p><u>Auxiliary switch rating:</u> 5 Amp resistive, 250 Vac</p>
---	---