

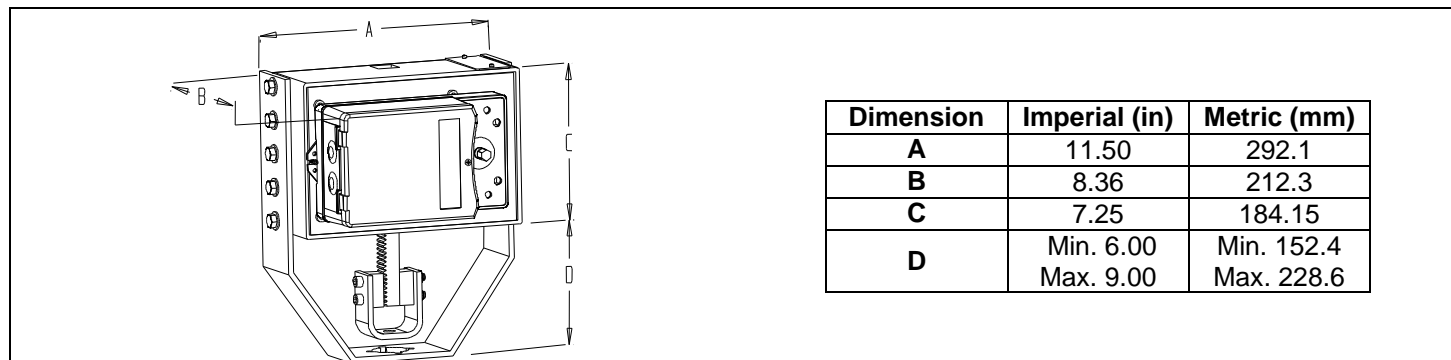

**Features:**

- Force up to 1500 lb [6750 N].
- Clutch for manual adjustments.
- Maintenance free.
- Control signal fully programmable.
- Fail safe (battery backup) (on model 110 and 210).

**MM100**  
**MM110**  
**MM200**  
**MM210**

Technical Data	MM100	MM110	MM200	MM210
Fail safe	No	Yes	No	Yes
Power supply	110 to 130 Vac, 50/60Hz or 28 to 32 Vdc or 22 to 26 Vac		220 to 240 Vac, 50/60Hz or 28 to 32 Vdc or 22 to 26 Vac	
Approvals	 Class 2			
Vertical force	1500 lb. [6750 N] at rated voltage			
Stroke / lift time	2 to 7 min, depending upon stroke, force independent			
Feedback	4 to 20 mA or 2 to 10 Vdc adjustable			
Power consumption	30 VA			
Electrical connection	18 AWG [0.8 mm <sup>2</sup> ] minimum			
Inlet bushing	2 inlet bushing of 7/8 in [22.2 mm]			
Control signal	Analog, Digital or PWM programmable (factory set with analog control signal)			
Stroke / lift	Electronically adjustable from 1in to 3.5 in [2.54 cm to 8.89 cm]			
Direction	Reversible, normally up position (open) or normally down position (close) (factory set normally down)			
Ambient temperature	0°F to 122°F [-18° C to 50°C]			
Storage temperature	-22°F to +122°F [-30° C to +50° C]			
Relative Humidity	5 to 95 % non condensing.			
Weight	45 lbs. [20.5 kg]			
<b>Warning: Do not press the clutch when actuator is powered</b>				

**Dimensions**

**Caution**

We strongly recommend that all Neptronic® products be wired to a separate transformer and that transformer shall service only Neptronic® products. This precaution will prevent interference with, and/or possible damage to incompatible equipment.  
 When multiple actuators are wired on a single transformer, polarity must be observed. Long wiring runs create voltage drop which may affect the actuator performance..

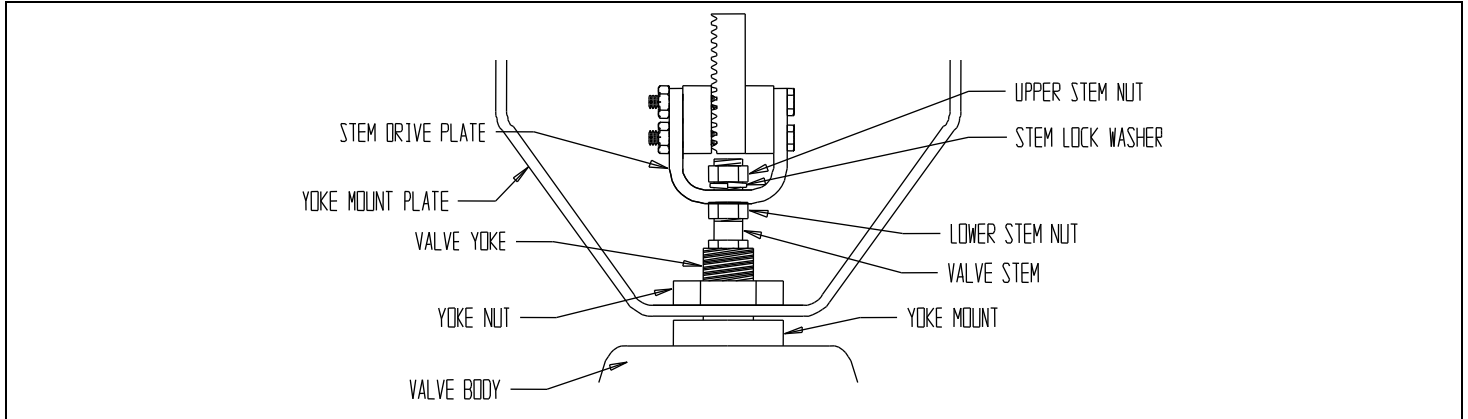
**Mounting on valve**

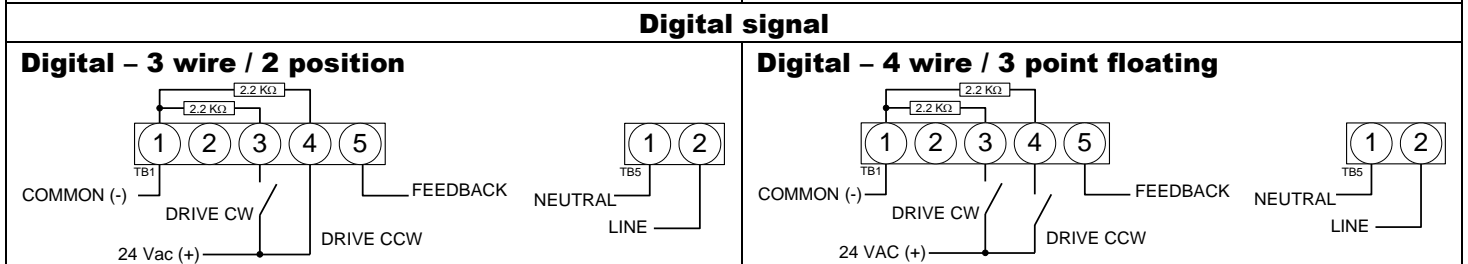
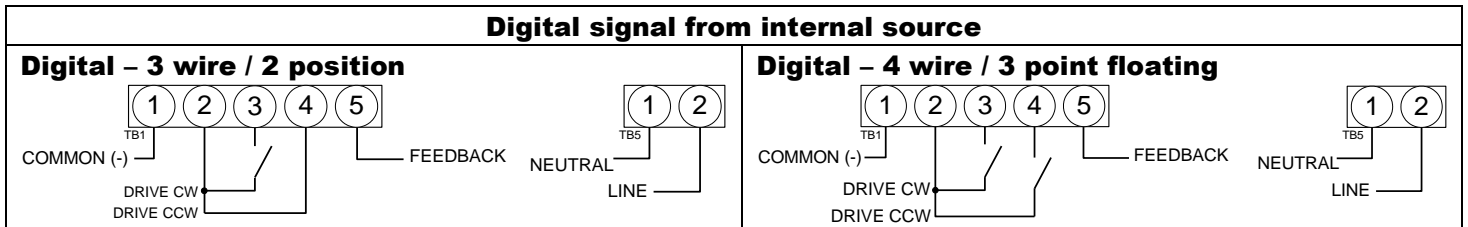
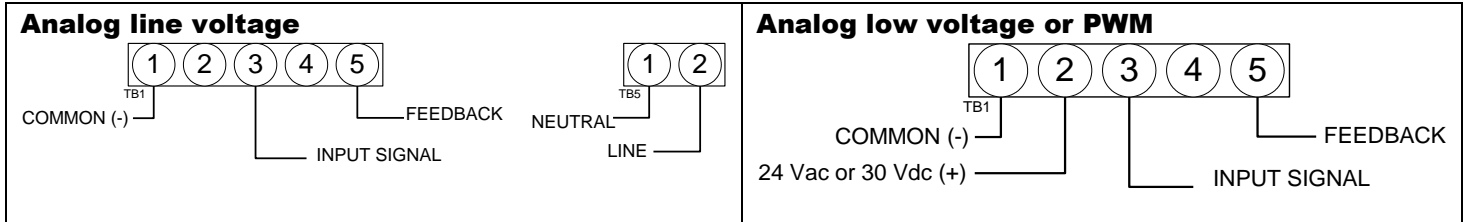

**Wiring Diagrams**



Special consideration for Digital control

In this mode, the actuator is sensitive to induced electrical voltages **from external sources**. To prevent such interference, if the signal on pins 4 and 3 on TB1 are from an **external 24 Vac source**, install a resistor 2.2kohm, 0.5W between pins 4 and 1 and another of 2.2kohms, 0.5W between pins 3 and 1 of TB1. These resistors are included.

**Input Signal and Feedback setup**

	<b>Input Signal</b>	<b>Feedback</b>
<b>Analog Mode</b>	Input Signal is set with Dipswitch # 3 DS1-3 at OFF = 2 – 10Vdc (default setting) DS1-3 at ON = 4 – 20mA	Feedback is set with Dipswitch #4 DS1-4 at OFF = 4 – 20mA (default setting) DS1-4 at ON = 2 – 10Vdc
<b>Digital &amp; PWM Mode</b>	No Input Signal Setting <i>DS1-3 MUST be at OFF</i>	

**PC Board**

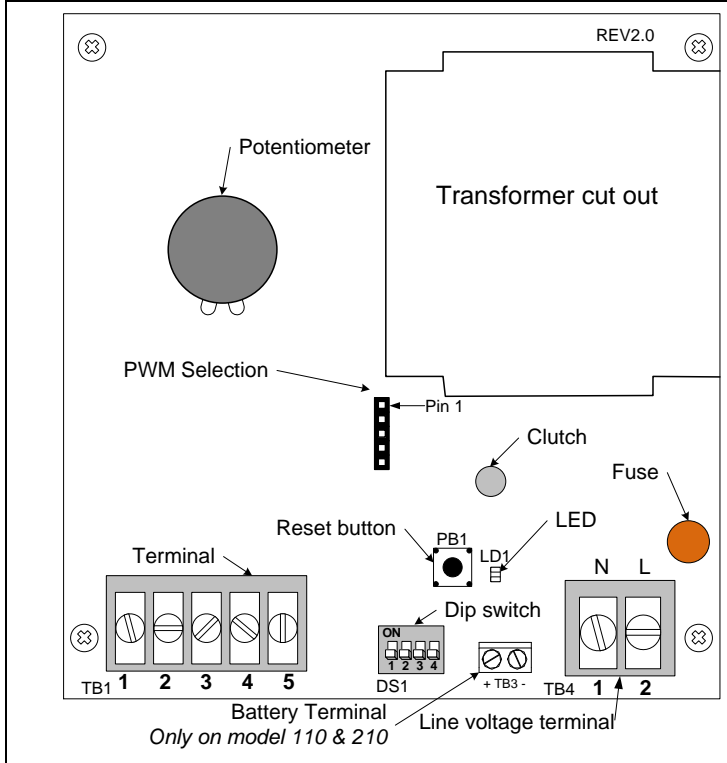

**Dip switch settings**

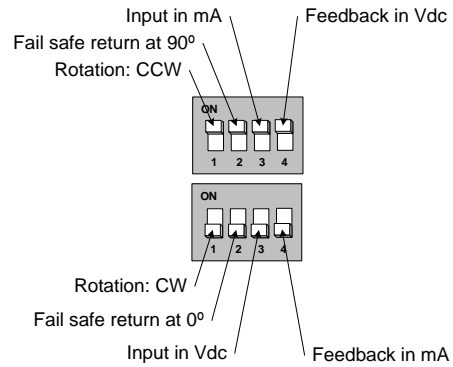

Default Setting = All dipswitches at OFF

**Stroke adjustment – No control signal change**

1. Apply power and, **WAIT FOR LED TO BE OFF (around 10 seconds)**.
2. Press and release the reset button to start the auto-stroke process. The LED should be illuminated.  
When the desired start position is reached, press and release the reset button. The actuator will now go the end position. (you can also press and release the reset button when it's reaches the end position) The LED will extinguish, the process is complete.

**Programming – Change of control signal & PWM pulse setting**

- a. Remove power and put all dip switches "OFF" (factory preset).
- b. Apply power and, **within 10 seconds**, press and release the reset button. The LED should be blinking.
- c. Select the control signal with dip switches:

	Digital or Analog Modes	PWM Mode
Move switch <b>No1</b> "ON" and then "OFF".	<b>Digital</b> (On/Off or 3 point floating)	5 sec. pulse (factory preset)
Move switch <b>No2</b> "ON" and then "OFF".	<b>Analog</b> (Default)	25 sec. pulse

**Stroke adjustment**

see the stroke adjustment section above.

**Enabling or disabling PWM mode**

1. Remove power supply to actuator
2. Install jumper between pin 3 & 4 of J3/4
3. Select the desired action using the dipswitches (DS1):
 

DS1-1	DS1-2	Action
OFF	ON	Enable PWM Mode
ON	OFF	Disable PWM Mode
4. Re-apply power supply to actuator
5. **Wait 5 seconds**
6. Remove power supply to actuator
7. Remove jumper between pin 3 & 4 of J3/4, re-install it between pin 4 & 5.
8. Re-apply power supply to actuator  
*PWM is factory preset at 5 sec. pulse, refer to programming section above to change pulse setting.*

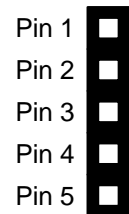

**J5**

When not used for programming, jumper is placed between pin 4 & 5

**Zero and span calibration**

This feature is applicable to analog control signal only.

1. Remove power and put all dip switches "OFF". (factory preset).
2. Apply power and, **within 10 seconds** press and **hold** the reset button until the LED blinks once. The Zero and span calibration process then start.
3. Release the reset button. The LED is now constantly illuminated.
4. Apply new minimum voltage.  
It can be any value between 0 to 7 Vdc, with an external 0 to 10 volt supply (ex: MEP).
5. Press and release the reset button to memorize the new minimum voltage. The LED blinks.
6. Apply new maximum voltage.  
It can be any value between 3 to 10 Vdc, this value should be greater than the new minimum value.
7. Press and release the reset button to memorize the new maximum voltage. The LED blinks. The Zero and span calibration process is complete.

**Note:** To reset zero and span to 2 to 10 Vdc (factory value). You just have to re-select the analog control signal mode, see Programming.