



Features:

- Mounts easy on round & square shaft (with option -8)
- External clutch for manual adjustments
- Maintenance free
- Position indicator
- Control signal fully programmable
- The fastest actuator of the world (model BM_ __FF)
- Fail safe by *Enerdrive System*¹ (on model 060 & 080)
- Auxiliary switches (on model 020 & 080)

BM000
BM020
BM060
BM080
BM000FF
BM020FF
BM060FF
BM080FF
BM000FF
BM020FF
BM060FF
BM080FF

Technical Data	BM000	BM060	BM000F	BM060F	BM000FF	BM060FF	BM020	BM080	BM020F	BM080F	BM020FF	BM080FF
Fail safe ¹	No	Yes	No	Yes	No	Yes	No	Yes	No	Yes	No	Yes
Power consumption	6 VA	15VA Peak,6VA	15 VA	24VA Peak,15VA	15 VA	24VA Peak,15VA	6 VA	15VA Peak,6VA	15 VA	24VA Peak,15VA	15 VA	24VA Peak,15VA
Torque	50 in.lb. [5.6 Nm] at rated voltage		35 in.lb. [3.9 Nm] at rated voltage		25 in.lb. [2.8 Nm] at rated voltage		50 in.lb. [5.6 Nm] at rated voltage		35 in.lb. [3.9 Nm] at rated voltage		25 in.lb. [2.8 Nm] at rated voltage	
Running time through 90°	20 to 30 sec torque dependant		3.5 to 4.5 sec torque dependant		1.5 to 2.5 sec torque dependant		20 to 30 sec torque dependant		3.5 to 4.5 sec torque dependant		1.5 to 2.5 sec torque dependant	
Auxiliary switches	No						Yes (2)					
Ingress protection	IP22 equivalent to Nema type 2, IP54 equivalent to Nema type 3R if water tight inlet bushings (not supplied NEP617) are installed						IP22 equivalent to Nema type 2					
Feedback	4 to 20 mA or 2 to 10 Vdc adjustable											
Power supply	22 to 26 Vac or 28 to 32 Vdc											
Electrical connection	18 AWG [0.8 mm ²] minimum											
Inlet bushing	2 inlet bushings: 13/16" [20.6mm]											
Control signal	Analog, Digital or Pulse with modulation (PWM) programmable (factory set with Analog control signal)											
Angle of rotation	0 to 90 degrees, mechanically adjustable (factory set with 90° stroke)											
Direction of rotation	Reversible, Clockwise (CW), or Counterclockwise (CCW) (factory set with CW direction)											
Ambient temperature	-22°F to 122°F [-30°C to 50°C]											
Storage temperature	-22°F to 122°F [-30°C to 50°C]											
Relative Humidity	5 to 95 % non condensing.											
Weight	3 lbs. [1.4 kg]											
Warning: Do not press the clutch when actuator is powered.												

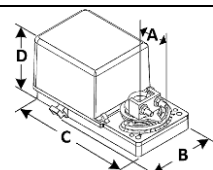
Dimensions

	Dimension		Inches (in)	Metric (mm)
	A		1.50	38.1
	B		3.64	92.5
	C		6.60	167.5
	D	model 000 & 060		3.02
model 020 & 080		3.81	96.8	

¹ Enerdrive System U.S.A. Patent #5,278,454

Caution

We strongly recommend that all Neptronic® products be wired to a separate transformer and that transformer shall service only Neptronic® products. This precaution will prevent interference with, and/or possible damage to incompatible equipment. When multiple actuators are wired on a single transformer, polarity must be observed. Long wiring runs create voltage drop which may affect the actuator performance.

Mechanical Installation

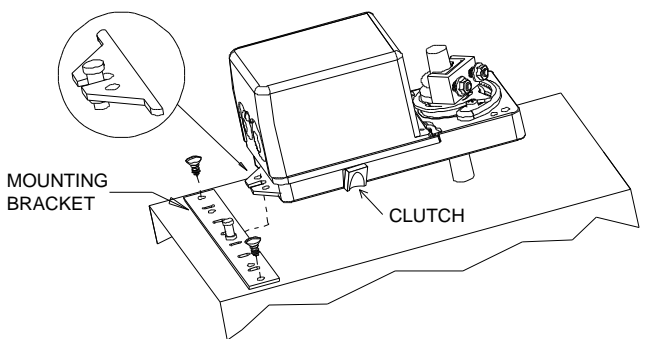

1. Manually close the damper blades and position the actuator at 0° or 90°.
2. Slide the actuator onto the shaft.
3. Tighten the nuts on the “U” bolt to the shaft with an 8mm wrench to a torque of 60 in.lb. [6.7 Nm].
4. Slide the mounting bracket under the actuator. Ensure free movement of the slot at the base of the actuator. The bracket pin must be placed in the mid distance of the slot.
5. Fix the bracket to the ductwork with #8 self-tapping screws.

Wiring Diagrams

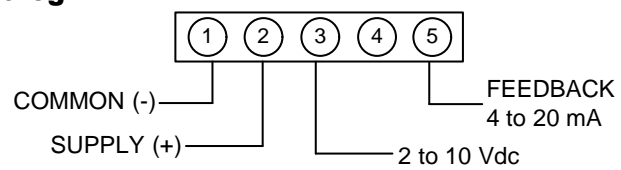
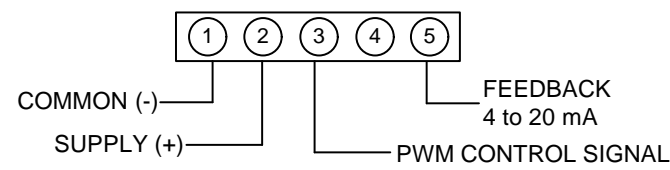
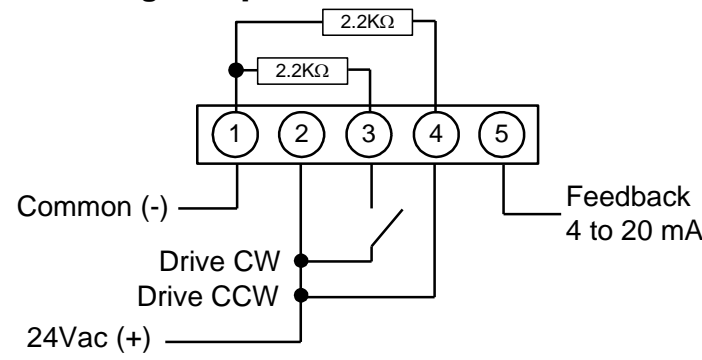
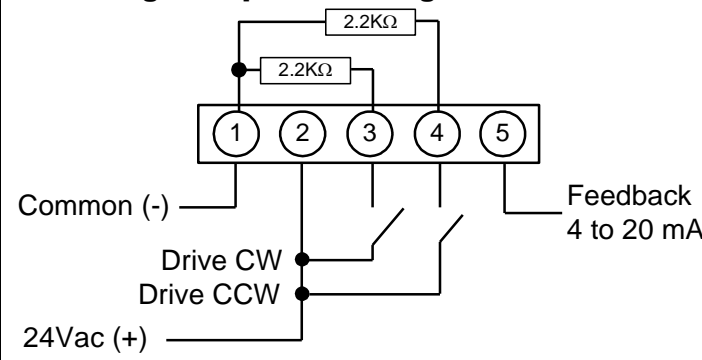
<p>Analogue</p>  <p>For 4 to 20mA control signal, connect supplied 500 Ohm resistor between pins 1 and 3. For 2 to 10Vdc feedback signal, connect supplied 500 Ohm resistor between pins 1 and 5.</p>	<p>PWM</p> 
<p>3-wire/Digital 2 positions</p> 	<p>4-wire/Digital 3 point floating</p> 
<p>Note: In Digital Mode, the actuator is sensitive to induced electrical voltages from external sources. To prevent interference, install a 2.2k Ohm, 0.5 W resistor (included) between pins 1 and 3 and another between pins 1 and 4 of TB1 as shown above.</p> <p>Note: In any of the above wiring configurations, connect a supplied 500 Ohm resistor between pins 1 and 5 for a 2-10Vdc feedback signal.</p>	

PC Board

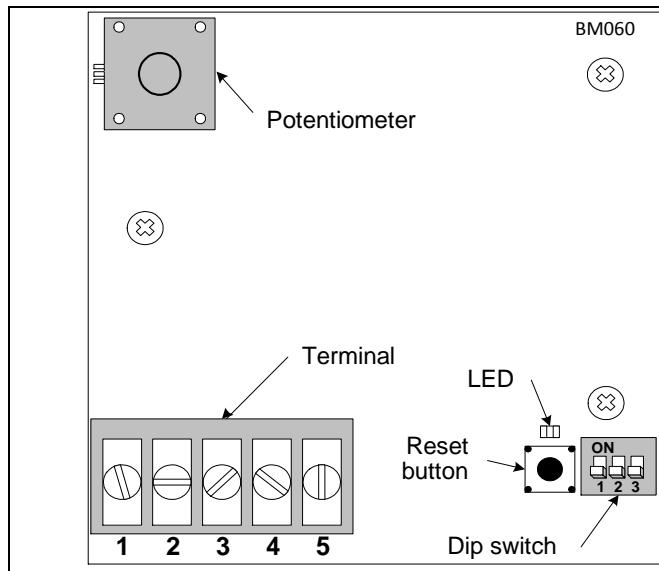

DIP Switch Settings

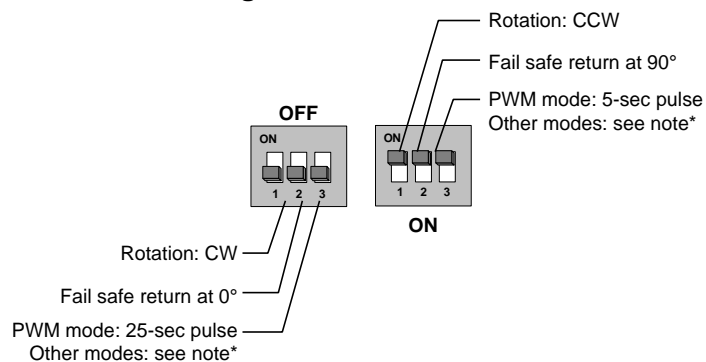

NOTE*: To use DIP switch #3 in other modes (analog/digital), refer to Feedback Selection (CCW Direction) on page 4.

Stroke Adjustment – No control signal change

1. Apply power and, **wait for at least 10 seconds.**
2. Press and release the reset button to start the auto-stroke process. The LED should be illuminated.
 - a. **First option:**
The actuator will then travel in both directions to find its limits and position itself according to the demand. The LED will extinguish, the process is complete.
 - b. **Second option:**
When the desired end position is reached, press and release the reset button. The actuator goes to the start position. You can also press and release the reset button when it reaches the start position. Once this process is complete, the LED extinguishes.

Programming – Change of control signal

- a. Remove power and put all dip switches to "OFF" (Default).
- b. Apply power and, **within 10 seconds**, press and release the reset button. The LED should be blinking.
- c. Select the control signal with DIP switches:

DIP Switch	Signal
Move DS #1 to ON and then OFF	Digital, On/Off or 3 point floating
Move DS #2 to ON and then OFF	PWM
Move DS #3 to ON and then OFF	Analog (default)
- d. If PWM mode is selected; when programming is done
 - If DIP switch #3 is ON, PWM uses 5-second pulse
 - If DIP switch #3 is OFF, PWM uses 25-second pulse

Stroke adjustment

see the stroke adjustment section above.

Feedback selection (CCW direction)

To select the CCW direction, set DS #1 to ON, and if the actuator is in Analog or Digital mode, you can program the feedback signal direction.

If switch No3 is "OFF":

The feedback control is automatically reverse to 4 to 20 mA for 90 to 0 degrees.

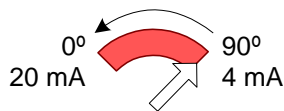

If switch No3 is "ON":

The feedback control is to 20 to 4 mA for 90 to 0 degrees.

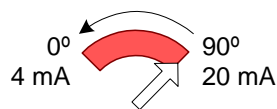

Zero and span calibration

This feature is applicable to analog control signal only.

1. Remove power and put all dip switches "OFF". (factory preset).
2. Apply power and within 10 seconds press and hold the reset button until the LED flashes once. When the LED flashes, release the reset button, the LED remains illuminated and the zero and span calibration process starts. NOTE: Do not hold the reset button for too long as it may cancel the process.
3. Apply new minimum voltage.
It can be any value between 0 to 7 Vdc, with an external 0 to 10 volt supply (ex: MEP).
4. Press and release the reset button to memorize the new minimum voltage. The LED flashes once and then remains illuminated.
5. Apply new maximum voltage.
It can be any value between 3 to 10 Vdc; this value should be greater than the new minimum value.
6. Press and release the reset button to memorize the new maximum voltage. The LED flashes once and then turns off. The Zero and span calibration process is complete.

Note: The voltage difference between the minimum voltage and high voltage settings must be at least 3V. If not, the actuator will ignore the values entered and use the previous values. For example, a minimum voltage of 5V and a maximum voltage of 7V represent a difference of 2V.

Note: To reset zero and span to 2 to 10 Vdc (factory value), re-select the analog control signal mode, see Programming.